SERVICE SPECIFICATIONS

	Page
CLUTCH	A-2
MANUAL TRANSMISSION (H140F, H150F and H151F)	A-3
AUTOMATIC TRANSMISSION	A-5
TRANSFER (Full-Time 4WD Type)	A-9
TRANSFER (Part-Time 4WD Type)	A-11
PROPELLER SHAFT	A-13
SUSPENSION AND AXLE	A-14
BRAKE SYSTEM	A-19
STEERING	A-21
BODY	A-23
WINCH	A-24
LUBRICANT	A-27

CLUTCH**Specifications**

Pedal height (from asphalt sheet)			173 mm	6.81 in.
Pedal freeplay	w/o Clutch booster		13 – 23 mm	0.51 – 0.91 in.
	w/ Clutch booster		15 – 30 mm	0.59 – 1.18 in.
Push rod play at pedal top			1 – 5 mm	0.04 – 0.20 in.
Booster air valve stroke at pedal top			5 – 9 mm	0.20 – 0.35 in.
Booster push rod to piston clearance		w/ SST	0 mm	0 in.
Disc rivet head depth		Limit	0.3 mm	0.012 in.
Disc runout		Limit	0.8 mm	0.031 in.
Diaphragm spring tip alignment		Limit	1.0 mm	0.039 in.
Diaphragm spring finger wear	Depth	Limit	0.6 mm	0.024 in.
	Width	Limit	5.0 mm	0.197 in.
Flywheel runout		Limit	0.2 mm	0.008 in.

Torque Specifications

Part tightened	kg-cm	ft-lb	N·m
Master cylinder × Body	80	69 in.-lb	7.8
Clutch line union	155	11	15
Clevis lock nut	250	18	25
Master cylinder × Clutch booster	130	9	13
Clutch booster × Body	130	9	13
Accumulator bracket × Accumulator housing	55	48 in.-lb	5.4
Accumulator line union	155	11	15
Accumulator bleeder plug	110	8	11
Release cylinder set bolt	120	9	12
Release cylinder bleeder plug	110	8	11
Clutch cover × Flywheel			
H151F transmission	400	29	39
Others	195	14	19

MANUAL TRANSMISSION (H140F, H150F and H151F)**Specifications**

Output shaft			
1st gear journal diameter	Limit	49.979 mm	1.9677 in.
2nd gear journal diameter	Limit	57.984 mm	2.2828 in.
3rd gear journal diameter	Limit	37.979 mm	1.4952 in.
5th gear journal diameter	Limit	45.984 mm	1.8104 in.
Frangé thickness	Limit	4.725 mm	0.1860 in.
Runout	Limit	0.05 mm	0.0020 in.
Counter gear			
Roller bearing journal diameter	STD	35.957 – 35.970 mm	1.4156 – 1.4161 in.
	Limit	35.970 mm	1.4161 in.
Gear thrust clearance			
1st & 3rd gear	STD	0.1 – 0.45 mm	0.0039 – 0.0177 in.
	Limit	0.45 mm	0.0177 in.
2nd & 5th gear	STD	0.1 – 0.35 mm	0.0039 – 0.0138 in.
	Limit	0.35 mm	0.0138 in.
Reverse gear	STD	0.1 – 0.67 mm	0.0039 – 0.0264 in.
	Limit	0.67 mm	0.0264 in.
Gear oil clearance			
1st & 3rd gear	STD	0.020 – 0.073 mm	0.0008 – 0.0029 in.
	Limit	0.073 mm	0.0029 in.
2nd & 5th gear	STD	0.015 – 0.068 mm	0.0006 – 0.0027 in.
	Limit	0.068 mm	0.0027 in.
Shift fork to hub sleeve clearance	Limit	0.35 mm	0.0138 in.
Synchronizer ring to gear clearance			
1st & 2nd gear	STD	1.1 – 1.9 mm	0.0433 – 0.0748 in.
	Limit	1.1 mm	0.0433 in.
3rd & reverse gear	STD	0.8 – 1.6 mm	0.0315 – 0.0630 in.
	Limit	0.8 mm	0.0315 in.
Oil seal drive in depth			
Front bearing retainer		15.4 – 16.2 mm	0.6063 – 0.6378 in.
Input shaft to synchronizer ring			
	STD	0.8 – 1.6 mm	0.0315 – 0.0630 in.
	Limit	0.8 mm	0.0315 in.
Input shaft snap ring thickness			
	Mark		
	A	2.50 – 2.55 mm	0.0984 – 0.1004 in.
	B	2.55 – 2.60 mm	0.1004 – 0.1024 in.
	C	2.60 – 2.65 mm	0.1024 – 0.1043 in.
	D	2.65 – 2.70 mm	0.1043 – 0.1063 in.
	E	2.70 – 2.75 mm	0.1063 – 0.1083 in.
	F	2.75 – 2.80 mm	0.1083 – 0.1102 in.
Counter gear snap ring (Front bearing)			
	Mark		
	A	2.45 – 2.50 mm	0.0970 – 0.0984 in.
	B	2.50 – 2.55 mm	0.0984 – 0.1004 in.
	C	2.55 – 2.60 mm	0.1004 – 0.1024 in.
	D	2.60 – 2.65 mm	0.1024 – 0.1043 in.
	E	2.65 – 2.70 mm	0.1043 – 0.1063 in.
	F	2.70 – 2.75 mm	0.1063 – 0.1083 in.
Output shaft snap ring thickness			
Hub sleeve No.3	Mark		
	A	2.40 – 2.45 mm	0.0945 – 0.0965 in.
	B	2.45 – 2.50 mm	0.0965 – 0.0984 in.
	C	2.50 – 2.55 mm	0.0984 – 0.1004 in.
	D	2.55 – 2.60 mm	0.1004 – 0.1024 in.
	E	2.60 – 2.65 mm	0.1024 – 0.1044 in.
	F	2.65 – 2.70 mm	0.1044 – 0.1063 in.

Specifications (Cont'd)

Output shaft snap ring thickness (cont'd)				
Hub sleeve No.2	Mark			
	4	1.90 – 1.95 mm	0.0748 – 0.0768 in.	
	5	1.95 – 2.00 mm	0.0768 – 0.0787 in.	
	6	2.00 – 2.05 mm	0.0787 – 0.0807 in.	
	7	2.05 – 2.10 mm	0.0807 – 0.0827 in.	
	8	2.10 – 2.15 mm	0.0827 – 0.0847 in.	
	9	2.15 – 2.20 mm	0.0847 – 0.0866 in.	
	Hub sleeve No.1	Mark		
		A	2.90 – 2.95 mm	0.1142 – 0.1162 in.
B		2.95 – 3.00 mm	0.1162 – 0.1181 in.	
C		3.00 – 3.05 mm	0.1181 – 0.1201 in.	
D		3.05 – 3.10 mm	0.1201 – 0.1220 in.	
E		3.10 – 3.15 mm	0.1220 – 0.1240 in.	
Rear	Mark			
	A	2.40 – 2.45 mm	0.0945 – 0.0965 in.	
	B	2.45 – 2.50 mm	0.0965 – 0.0984 in.	
	C	2.50 – 2.55 mm	0.0984 – 0.1004 in.	
	D	2.55 – 2.60 mm	0.1004 – 0.1024 in.	
	E	2.60 – 2.65 mm	0.1024 – 0.1044 in.	
	F	2.65 – 2.70 mm	0.1044 – 0.1063 in.	
	G	2.70 – 2.75 mm	0.1063 – 0.1083 in.	
Oil pump				
	Body clearance of driven rotor	STD	0.075 – 0.170 mm	
		Limit	0.17 mm	
	Tip clearance of both rotors	STD	0.10 – 0.22 mm	
	Limit	0.22 mm		
			0.0030 – 0.0067 in.	
			0.0067 in.	
			0.0039 – 0.0087 in.	
			0.0087 in.	

Torque Specifications

Part tightened	kg-cm	ft-lb	N·m
Shift lever control retainer × Transmission case	170	12	17
Restrict pin	380	27	37
Oil receiver × Transmission case	120	7	12
Back-up light switch	450	33	44
Top switch	450	33	44
Drain plug	380	27	37
Front bearing retainer × Transmission case	170	12	16
Clutch housing × Transmission case	380	27	37
Oil strainer × Transfer adaptor	120	7	12
Oil receiver × Intermediate plate	185	13	18
Transmission case × Transfer adaptor	380	27	37
Rear bearing retainer × Intermediate plate	185	13	18
Shift fork No.1 set bolt	370	27	36
Shift fork No.2 set bolt	370	27	36
Shift fork No.3 set bolt	370	27	36
Reverse shift fork set bolt (4-Speed)	370	27	36
(5-Speed)	350	25	34
Screw plug	190	14	19
Oil pump cover × Transfer adaptor	170	12	17

AUTOMATIC TRANSMISSION**Specifications**

Engine stall revolution	3F engine	1,850 ± 150 rpm			
	1H engine	1,900 ± 150 rpm			
Engine idle speed	N range	3F engine	750 rpm		
		3F-E engine	650 rpm		
		1HZ engine	710 rpm		
		1HD-T engine	800 rpm		
Time lag	N range → D range	Less than 0.7 seconds			
	N range → R range	Less than 1.2 seconds			
Line pressure (wheel locked)					
Engine idling	3F engine	D range	3.7 – 4.3 kg/cm ²	53 – 61 psi	363 – 442 kPa
		R range	4.5 – 5.5 kg/cm ²	64 – 78 psi	441 – 539 kPa
	1H engine	D range	4.4 – 5.2 kg/cm ²	63 – 74 psi	431 – 510 kPa
		R range	6.5 – 8.6 kg/cm ²	92 – 122 psi	637 – 843 kPa
At stall	3F engine	D range	11.1 – 13.6 kg/cm ²	158 – 193 psi	1,089 – 1,344 kPa
		R range	14.0 – 17.0 kg/cm ²	199 – 242 psi	1,373 – 1,677 kPa
	1H engine	D range	9.9 – 12.5 kg/cm ²	141 – 178 psi	971 – 1,226 kPa
		R range	16.4 – 18.9 kg/cm ²	233 – 269 psi	1,608 – 1,853 kPa
Governor pressure		Output shaft rpm			
	3F, 3F-E engine	1,000	0.8 – 1.2 kg/cm ²	11 – 17 psi	78 – 118 kPa
		1,800	2.0 – 2.4 kg/cm ²	28 – 34 psi	196 – 235 kPa
		3,500	5.7 – 6.3 kg/cm ²	81 – 90 psi	559 – 618 kPa
	1HZ, 1HD-T engine	1,000	1.0 – 1.4 kg/cm ²	14 – 20 psi	98 – 137 kPa
		1,800	2.3 – 2.9 kg/cm ²	33 – 41 psi	226 – 284 kPa
		3,500	5.7 – 6.3 kg/cm ²	81 – 90 psi	559 – 618 kPa
Throttle cable adjustment			Between boot end face and inner cable stopper		
Throttle valve fully closed			0.5 – 1.0 mm	0.020 – 0.059 in.	
Throttle valve fully opened			32 – 34 mm	1.26 – 1.34 in.	
Torque converter installation					
	3F, 3F-E engine		16.5 mm (0.650 in.) or more		
	1HZ, 1HD-T engine		41.2 mm (1.622 in.) or more		
Torque converter runout	Limit		0.30 mm	0.0118 in.	
Drive plate runout	Limit		0.20 mm	0.0079 in.	

Specifications (Cont'd)

Shift point schedule

(Australia)

km/h (mph)

		Throttle valve fully open						(fully closed)		2 range	1 range
Engine	Tire size	1→2	2→3	3→O/D	O/D→3	3→2	2→1	*1	*2	3→2	2→1
3F-E	7.50R-16-6	37-52 (23-32)	83-98 (52-61)	122-137 (76-85)	112-128 (70-80)	72-87 (45-54)	31-46 (19-29)	80-92 (50-57)	76-87 (47-54)	85-101 (53-63)	39-54 (24-34)
	265/75R-15	35-50 (22-31)	80-95 (50-59)	117-132 (73-82)	108-123 (67-76)	70-84 (43-52)	30-44 (19-27)	77-88 (48-55)	73-84 (48-52)	82-97 (51-60)	37-52 (23-32)
1HD-T	7.50R-16-6	27-42 (17-26)	73-88 (45-55)	124-139 (77-86)	114-129 (71-80)	60-75 (37-47)	19-35 (12-22)	73-85 (45-53)	69-80 (43-50)	78-93 (48-58)	35-49 (22-30)
	265/75R-15	25-40 (16-25)	69-84 (43-52)	117-132 (73-82)	108-123 (67-76)	57-72 (35-45)	18-33 (11-21)	69-81 (43-50)	65-76 (40-47)	74-88 (46-55)	33-46 (21-29)

*1 Lock-up ON *2 Lock-up OFF

(Europe)

km/h (mph)

		Throttle valve fully open						(fully closed)		2 range	1 range
Engine	Tire size	1→2	2→3	3→O/D	O/D→3	3→2	2→1	*1	*2	3→2	2→1
3F-E	265/75R-15	35-50 (22-31)	80-95 (50-59)	117-132 (73-82)	108-123 (67-76)	70-84 (43-52)	30-44 (19-27)	77-88 (48-55)	73-84 (45-52)	82-97 (51-60)	37-52 (23-32)
	215/80R-16	33-47 (21-29)	76-90 (47-56)	111-125 (69-78)	103-117 (64-73)	66-80 (41-50)	28-42 (17-26)	73-84 (45-52)	69-80 (43-50)	78-92 (48-57)	36-50 (22-31)
1HZ	265/75R-15	30-45 (19-28)	74-89 (46-55)	117-132 (73-82)	108-123 (67-76)	64-79 (40-49)	25-39 (16-24)	72-83 (45-52)	67-79 (42-49)	76-91 (47-57)	36-51 (22-32)
	215/80R-16	29-43 (18-27)	70-84 (43-52)	111-125 (69-78)	103-116 (64-72)	61-75 (38-47)	24-38 (15-24)	68-79 (42-49)	64-75 (40-47)	73-87 (45-54)	34-48 (21-30)
1HD-T	265/75R-15	25-40 (16-25)	69-84 (43-52)	117-132 (73-82)	108-123 (67-76)	57-72 (35-45)	18-33 (11-21)	69-81 (43-50)	67-76 (40-47)	74-88 (46-55)	33-46 (21-29)
	215/80R-16	24-38 (15-24)	66-80 (41-50)	111-125 (69-78)	103-117 (64-73)	54-68 (34-42)	17-31 (11-19)	66-77 (41-48)	62-73 (39-45)	70-84 (43-52)	32-44 (20-27)

*1 Lock-up ON *2 Lock-up OFF

(Middle East)

km/h (mph)

		Throttle valve fully open						(fully closed)		2 range	1 range
Engine	Tire size	1→2	2→3	3→O/D	O/D→3	3→2	2→1	*1	*2	3→2	2→1
3F	7.50-16-6	31-47 (19-29)	77-92 (48-57)	121-137 (75-85)	112-127 (70-79)	67-82 (42-51)	26-41 (16-25)	74-86 (46-53)	70-81 (43-50)	79-94 (49-58)	45-58 (28-36)
	9.00-15-6	33-49 (21-30)	81-97 (50-60)	128-143 (80-89)	118-133 (73-83)	70-86 (43-53)	27-43 (17-27)	78-90 (48-56)	73-86 (45-53)	83-99 (52-62)	45-61 (28-38)
	31×10.5R-15	30-45 (19-28)	75-89 (47-55)	118-133 (73-83)	109-123 (68-76)	65-80 (40-50)	25-40 (16-25)	72-83 (45-52)	68-79 (42-49)	77-92 (48-57)	41-56 (25-35)
	7.50R-16-8	32-47 (20-29)	78-94 (48-58)	124-139 (77-86)	114-129 (71-80)	68-83 (42-52)	27-42 (17-26)	75-87 (47-54)	71-83 (44-52)	81-96 (50-60)	43-59 (27-37)

*1 Lock-up ON *2 Lock-up OFF

Specifications (Cont'd)

Shift point schedule (cont'd)

(Others)

km/h (mph)

Engine	Tire size	Throttle valve fully open						(fully closed)		2 range	1 range
		1→2	2→3	3→O/D	O/D→3	3→2	2→1	*1	*2	3→2	2→1
3F	7.50-16-6	31-47	77-92	121-137	112-127	67-82	26-41	74-86	70-81	79-94	43-58
	7.50-16-8	(19-29)	(48-57)	(75-85)	(70-79)	(42-51)	(16-25)	(46-53)	(43-50)	(49-58)	(28-36)
	9.00-15-6	33-49	81-97	128-143	118-133	70-86	27-43	78-90	73-86	83-99	45-61
		(21-30)	(50-60)	(80-89)	(73-83)	(43-53)	(17-27)	(48-56)	(45-53)	(52-62)	(28-38)
	31×10.5R-15	30-45	75-89	118-133	109-123	65-80	25-40	72-83	68-79	77-92	41-56
	(19-28)	(47-55)	(73-83)	(68-76)	(40-50)	(16-25)	(45-52)	(42-49)	(48-57)	(25-35)	
	7.50R-16-8	32-47	78-94	124-139	114-129	68-83	27-42	75-87	71-83	81-96	43-59
		(20-29)	(48-58)	(77-86)	(71-80)	(42-52)	(17-26)	(47-54)	(44-52)	(50-60)	(27-37)
	235/75R-15	28-42	69-83	110-123	101-115	60-74	23-37	67-78	63-74	71-85	39-52
		(17-26)	(43-52)	(68-76)	(63-71)	(37-46)	(14-23)	(42-48)	(39-46)	(44-53)	(24-32)
1HZ	7.50-16-6	31-47	77-92	121-137	112-127	67-82	26-41	74-86	70-81	79-94	43-58
	7.50-16-8	(19-29)	(48-57)	(75-85)	(70-79)	(42-51)	(16-25)	(46-53)	(43-50)	(49-58)	(28-36)
	7.50R-16-8	32-47	78-94	124-139	114-129	68-83	27-42	75-87	71-83	81-96	38-53
		(20-29)	(48-58)	(77-86)	(71-80)	(42-52)	(17-26)	(47-54)	(44-52)	(50-60)	(24-33)
	9.00-15-6	33-49	81-97	128-143	118-133	70-86	28-43	78-90	73-86	83-99	39-55
		(21-30)	(50-60)	(80-89)	(73-83)	(43-53)	(17-27)	(48-56)	(45-53)	(52-62)	(24-34)
	31×10.5R-15	30-45	75-89	118-133	109-123	65-80	25-40	72-83	68-79	77-92	36-51
		(19-28)	(47-55)	(73-83)	(68-76)	(40-50)	(16-25)	(45-52)	(42-49)	(48-57)	(22-32)
1HD-T	7.50-16-6	26-41	72-87	121-137	112-127	59-74	19-34	72-83	67-79	76-92	35-48
		(16-25)	(45-54)	(75-85)	(70-79)	(37-46)	(12-21)	(45-52)	(42-49)	(47-57)	(22-30)
	7.50-16-8	26-41	72-87	121-137	112-127	59-74	19-34	72-83	67-79	76-92	35-48
		(16-25)	(45-54)	(75-85)	(70-79)	(37-46)	(12-21)	(45-52)	(42-49)	(47-57)	(22-30)
	7.50R-16-8	27-42	73-88	124-139	114-129	60-75	19-35	73-85	69-80	78-93	35-49
	(17-26)	(45-55)	(77-86)	(71-80)	(37-47)	(12-22)	(45-53)	(43-50)	(48-58)	(22-30)	
	9.00-15-6	27-43	75-91	128-143	118-133	62-78	20-36	76-88	71-83	62-78	20-36
		(17-27)	(47-57)	(80-89)	(73-83)	(39-48)	(12-22)	(47-55)	(44-52)	(39-48)	(12-22)
	31×10.5R-15	25-40	70-84	118-133	109-123	57-72	18-33	70-81	65-77	74-89	34-47
		(16-25)	(43-52)	(73-83)	(68-76)	(35-45)	(11-21)	(43-50)	(40-48)	(46-55)	(21-29)

*1 Lock-up ON *2 Lock-up OFF

Torque Specifications

Part tightened		kg-cm	ft-lb	N·m
Engine × Transmission	8 mm	185	13	18
	10 mm	380	27	37
	12 mm	730	53	72
Drive plate × Crankshaft	3F engine	900	65	88
	1H engine	1,300	94	127
Torque converter × Drive plate	3F engine	290	21	28
	1H engine	550	40	54
Valve body	6 mm	100	7	10
	5 mm	55	48 in.-lb	5.4
Oil pan		70	61 in.-lb	6.9
Oil pan drain plug		280	20	27
Cooler pipe union nut		350	25	34
Testing plug		75	65 in.-lb	7.4
Neutral start switch (bolt)		130	9	13
Neutral start switch (nut)		70	61 in.-lb	6.9
Frame crossmember set bolt		620	45	61
Frame crossmember set nut		750	54	74
PTO × Drive shaft		200	14	20

TRANSFER (Full-Time 4WD Type)

Specifications

Input shaft assembly	Input gear snap ring thickness and power take-off gear snap ring thickness	Mark		
		A	2.0 mm	0.0787 in.
		B	2.1 mm	0.0827 in.
		C	2.2 mm	0.0866 in.
		D	2.3 mm	0.0906 in.
		E	2.4 mm	0.0945 in.
		F	2.5 mm	0.0984 in.
		G	2.6 mm	0.1024 in.
		H	2.7 mm	0.1063 in.
		J	2.8 mm	0.1102 in.
	Input shaft rear ball bearing snap ring thickness	Mark		
		A	2.0 mm	0.0787 in.
		B	2.1 mm	0.0827 in.
		C	2.2 mm	0.0866 in.
D		2.3 mm	0.0906 in.	
Idler gear assembly	Idler low gear thrust clearance	STD	0.125 – 0.275 mm	0.0049 – 0.0108 in.
		Limit	0.275 mm	0.0108 in.
	Idler low gear oil clearance	STD	0.015 – 0.068 mm	0.0006 – 0.0027 in.
		Limit	0.068 mm	0.0027 in.
Center differential assembly	High speed output gear thrust clearance	STD	0.10 – 0.25 mm	0.0039 – 0.0098 in.
		Limit	0.25 mm	0.0098 in.
	High speed output gear oil clearance	STD	0.015 – 0.071 mm	0.0006 – 0.0028 in.
		Limit	0.071 mm	0.0028 in.
	Center differential backlash	Limit	0.05 mm	0.0020 in.
	Front drive gear piece snap ring thickness	Mark		
		A	2.00 mm	0.0787 in.
		B	2.10 mm	0.0827 in.
		C	2.20 mm	0.0866 in.
		D	2.30 mm	0.0906 in.
		E	2.40 mm	0.0945 in.
		F	2.50 mm	0.0984 in.
		G	2.60 mm	0.1024 in.
		H	2.70 mm	0.1063 in.
		J	2.80 mm	0.1102 in.
		K	1.80 mm	0.0709 in.
	Preload adjusting shim (Idler gear side)	L	1.90 mm	0.0748 in.
		Mark		
		A	0.15 mm	0.0059 in.
		B	0.30 mm	0.0118 in.
C		0.45 mm	0.0177 in.	
D		2.40 mm	0.0945 in.	
E		2.60 mm	0.1024 in.	
F		2.80 mm	0.1102 in.	
G		3.00 mm	0.1181 in.	
H	3.20 mm	0.1260 in.		
J	3.40 mm	0.1339 in.		
K	3.60 mm	0.1417 in.		
L	3.80 mm	0.1496 in.		
M	4.00 mm	0.1575 in.		

Specifications (Cont'd)

Center differential assembly (cont'd)	Preload adjusting shim (Output shaft side)	Mark		
		A	0.15 mm	0.0059 in.
		B	0.30 mm	0.0118 in.
		C	0.45 mm	0.0177 in.
		D	1.00 mm	0.0394 in.
		E	1.20 mm	0.0472 in.
		F	1.40 mm	0.0551 in.
		G	1.60 mm	0.0630 in.
		H	1.80 mm	0.0709 in.
		J	2.00 mm	0.0787 in.
		K	2.20 mm	0.0866 in.
		L	2.40 mm	0.0945 in.
		M	2.60 mm	0.1024 in.

Torque Specifications

Part tightened	kg-cm	ft-lb	N·m
Center differential rear case set bolt	1,000	72	98
(Temporary tighten)	900	65	88
Oil pump plate set bolt	50	43 in.-lb	4.9
Screw plug (Rear extension housing)	190	14	19
Oil pump cover set screw	50	43 in.-lb	4.9
Oil receiver set bolt	55	48 in.-lb	5.4
Shift outer lever × Inner lever	120	9	12
Oil strainer set bolt	50	43 in.-lb	4.9
Front case × Rear case	380	27	37
Case cover × Rear case	380	27	37
Rear extension housing × Rear case	380	27	37
Front extension housing × Front case	380	27	37
Power take-off case × Front case	195	14	19
Power take-off cover × Front case	195	14	19
Screw plug (Front case)	190	14	19
4WD indicator switch	380	27	37
Motor actuator × Front case	195	14	19

TRANSFR (Part-Time 4WD Type)

Specifications

Input shaft	Input gear snap ring thickness and power take-off gear snap ring thickness	Mark		
		A	2.0 mm	0.0787 in.
		B	2.1 mm	0.0827 in.
		C	2.2 mm	0.0866 in.
		D	2.3 mm	0.0906 in.
		E	2.4 mm	0.0945 in.
		F	2.5 mm	0.0984 in.
		G	2.6 mm	0.1024 in.
		H	2.7 mm	0.1063 in.
		J	2.8 mm	0.1102 in.
	Input shaft rear ball bearing snap ring thickness	Mark		
		A	2.0 mm	0.0787 in.
		B	2.1 mm	0.0827 in.
		C	2.2 mm	0.0866 in.
D		2.3 mm	0.0906 in.	
Output shaft	High speed gear thrust clearance	STD	0.28 – 0.43 mm	0.0110 – 0.0169 in.
		Limit	0.43 mm	0.0169 in.
	Low speed gear thrust clearance	STD	0.20 – 0.45 mm	0.0079 – 0.0177 in.
		Limit	0.45 mm	0.0177 in.
	High speed gear and low speed gear oil clearance	STD	0.0075 – 0.034 mm	0.0003 – 0.0013 in.
		Limit	0.034 mm	0.0013 in.
	Output shaft journal outer diameter (High speed gear)	Limit	41.984 mm	1.6529 in.
		Limit	42.984 mm	1.6923 in.
	Output shaft synchronizer ring to gear clearance	STD	0.75 – 1.65 mm	0.0295 – 0.0650 in.
		Limit	0.75 mm	0.0295 in.
	Shift fork to hub sleeve clearance	STD	0.1 – 0.4 mm	0.0039 – 0.0157 in.
		Limit	0.4 mm	0.0157 in.
	Output shaft journal length (High speed gear)	Limit	46.55 mm	1.8327 in.
		Limit	62.35 mm	2.4547 in.
	High and low hub sleeve snap ring thickness	Mark		
		A	2.60 mm	0.1024 in.
		B	2.65 mm	0.1043 in.
		C	2.70 mm	0.1063 in.
		D	2.75 mm	0.1083 in.
		E	2.80 mm	0.1102 in.
F		2.85 mm	0.1122 in.	
G		2.90 mm	0.1142 in.	
Front drive gear piece snap ring thickness	Mark			
	A	2.0 mm	0.0787 in.	
	B	2.1 mm	0.0827 in.	
	C	2.2 mm	0.0866 in.	
	E	2.4 mm	0.0945 in.	

Specifications (Cont'd)

Front extension housing assembly	Bearing snap ring	Mark			
		A	1.7 mm	0.0669 in.	
			B	1.8 mm	0.0709 in.
	Front output shaft	Mark	A	1.8 mm	0.0709 in.
			B	1.9 mm	0.0748 in.
			C	2.0 mm	0.0787 in.
			D	2.1 mm	0.0827 in.
			E	2.2 mm	0.0866 in.
	Preload adjusting shim (Idler gear side)	Mark	A	0.15 mm	0.0059 in.
			B	0.30 mm	0.0118 in.
			C	0.45 mm	0.0177 in.
			D	2.40 mm	0.0945 in.
			E	2.60 mm	0.1024 in.
			F	2.80 mm	0.1102 in.
			G	3.00 mm	0.1181 in.
			H	3.20 mm	0.1260 in.
			J	3.40 mm	0.1339 in.
			K	3.60 mm	0.1417 in.
			L	3.80 mm	0.1496 in.
	Preload adjusting shim (Output shaft side)	Mark	M	4.00 mm	0.1575 in.
			A	0.15 mm	0.0059 in.
			B	0.30 mm	0.0118 in.
			C	0.45 mm	0.0177 in.
			D	1.00 mm	0.0394 in.
			E	1.20 mm	0.0473 in.
			F	1.40 mm	0.0551 in.
			G	1.60 mm	0.0630 in.
H			1.80 mm	0.0709 in.	
J			2.00 mm	0.0787 in.	
K			2.20 mm	0.0866 in.	
L	2.40 mm	0.0945 in.			
M	2.60 mm	0.1024 in.			

Torque Specifications

Part tightened	kg-cm	ft-lb	N·m
Screw plug (Rear extension housing)	190	14	19
Oil pump cover	50	43 in.-lb	4.9
Oil receiver × Front case	55	48 in.-lb	5.4
Shift outer lever × Inner lever	120	9	12
Oil strainer × Rear case	50	43 in.-lb	4.9
Oil receiver × Rear case	130	9	13
Front case × Rear case	380	27	37
Case cover × Rear case	380	27	37
Rear extension housing × Rear case	380	27	37
Lock nut	1,300	94	128
Front extension housing × Front case	380	27	37
Power take-off case × Front case	195	14	19
Power take-off cover × Front case	195	14	19
4WD indicator switch	380	27	37
Screw plug (Front case)	190	14	19
Motor actuator × Front case	195	14	19

PROPELLER SHAFT**Specifications**

Propeller shaft runout		Limit	0.8 mm	0.031 in.
Spider bearing axial play			Less than 0.05 mm (0.0020 in.)	
Snap ring thickness	Color	Mark		
Front propeller shaft	None	1	2.100 – 2.150 mm	0.0827 – 0.0846 in.
	None	2	2.150 – 2.200 mm	0.0846 – 0.0866 in.
	None	3	2.200 – 2.250 mm	0.0866 – 0.0886 in.
	Brown	None	2.250 – 2.300 mm	0.0886 – 0.0906 in.
	Blue	None	2.300 – 2.350 mm	0.0906 – 0.0925 in.
	None	6	2.350 – 2.400 mm	0.0925 – 0.0945 in.
	None	7	2.400 – 2.450 mm	0.0945 – 0.0965 in.
	None	8	2.450 – 2.500 mm	0.0965 – 0.0984 in.
Rear propeller shaft	None		2.00 mm	0.0787 in.
	Brown		2.03 mm	0.0799 in.
	Blue		2.06 mm	0.0811 in.
	None		2.09 mm	0.0823 in.

Torque Specifications

Part tightened	kg-cm	ft-lb	N·m
Front propeller shaft × Front differential	750	54	74
Front propeller shaft × Transfer	750	54	74
Rear propeller shaft × Rear differential	900	65	88
Rear propeller shaft × Transfer	900	65	88

SUSPENSION AND AXLE

Specifications

Cold tire inflation pressure	Destination	Grade	Tire size	Pressure kg/cm ² (psi, kPa)						
				Front	Rear					
	Australia	STD	7.50R16-6PRLT	2.4 (34, 240)	3.0 (43, 300)					
			7.50R16-8PRLT	2.4 (34, 240)	3.0 (43, 300)					
		GX, VX	7.50R16-6PRLT	2.4 (34, 240)	3.2 (46, 320)					
			265/75R15 112S	1.8 (27, 180)	1.8 (27, 180)					
	Destination	Model	Tire size	Pressure kg/cm ² (psi, kPa)						
	Europe	FJ series	215/80R16 107S	2.1 (30, 210)	2.4 (35, 240)					
			265/75R15 112S	1.8 (27, 180)	1.8 (27, 180)					
		HZJ (STD) series	215/80R16 107S	2.1 (30, 210)	2.2 (32, 220)					
			HZJ (GX) series	215/80R16 107S	2.2 (32, 220)	2.4 (35, 240)				
		HDJ series		265/75R15 112S	1.8 (26, 180)	1.8 (26, 180)				
			Others	All models	215/80R16 107S	2.3 (23, 230)	2.4 (33, 240)			
		265/75R15 112S			1.8 (26, 180)	1.8 (26, 180)				
		Chassis ground clearance	Measure clearance		Clearance mm (in.)					
	Spring follower clearance		Front		25 (0.98)					
Rear			45 (1.77)							
Front wheel alignment	Camber		Inspection standard	1°00' ± 45' (1° ± 0.75°)						
	Left-right error		30' (0.5°) or less							
	Caster		Tire size		Inspection standard	1°40' ± 60' (1.67° ± 1°)				
			31 × 10.50R15-6PRLT					Left-right error	30' (0.5°) or less	
			265/75R15 112S							
			9.00-15-6PRLT							
	Others		Inspection standard	3°00' ± 60' (3° ± 1°)						
	Left-right error		30' (0.5°) or less							
	Steering axis inclination			Inspection standard	13°00' ± 45' (13° ± 0.75°)					
	Left-right error			30' (0.5°) or less						
Toe-in	Tire size		Inspection standard	4 ± 2 mm (0.16 ± 0.08 in.)						
	7.00-15-6PRLT					Adjustment standard	4 ± 1 mm (0.16 ± 0.04 in.)			
	9.00-15-6PRLT									
	7.00-16-6PRLT									
	7.50-16-6PRLT									
	7.50-16-8PRLT									
	215/80R16 107S		Inspection standard	2 ± 2 mm (0.08 ± 0.08 in.)						
	265/75R15 112S					Adjustment standard	2 ± 1 mm (0.08 ± 0.04 in.)			
	31 × 10.50R15-6PRLT									
7.50R16-6PRLT										
7.50R16-8PRLT										

Specifications (Cont'd)

Front wheel alignment (cont'd)	Wheel angle	PS	MS		
		35° +0° -3°	32° +0° -3°		
	Max. Inside wheel				
	Outside wheel	31°	29°		
	Side slip (Reference only)	3.0 mm/m (0.118 in./3.3 ft) or less			
Front differential	Drive pinion bearing preload (at starting)				
	New bearing	10 – 16 kg-cm	8.7 – 13.9 in.-lb 1.0 – 1.6 N·m		
	Reused bearing	5 – 8 kg-cm	4.3 – 6.9 in.-lb 0.5 – 0.8 N·m		
	Total preload (at starting)				
	Add drive pinion bearing preload	4 – 6 kg-cm	3.5 – 5.2 in.-lb 0.4 – 0.6 N·m		
	Drive pinion to ring gear backlash	0.13 – 0.18 mm	0.0051 – 0.0071 in.		
	Pinion gear to side gear backlash	0.05 – 0.20 mm	0.0020 – 0.0079 in.		
	Ring gear runout	Limit	0.10 mm	0.0039 in.	
	Companion flange deviation	Limit			
		Radial	0.10 mm	0.0039 in.	
		Lateral	0.10 mm	0.0039 in.	
	Side gear thrust washer thickness 2 pinion type		1.6 mm	0.063 in.	
			1.7 mm	0.067 in.	
			1.8 mm	0.071 in.	
		w/ Differential lock		0.9 mm	0.035 in.
				1.0 mm	0.039 in.
				1.1 mm	0.043 in.
				1.2 mm	0.047 in.
				1.3 mm	0.051 in.
				1.70 mm	0.0669 in.
		Drive pinion adjusting plate washer thickness		1.73 mm	0.0681 in.
			1.76 mm	0.0693 in.	
			1.79 mm	0.0705 in.	
			1.82 mm	0.0717 in.	
			1.85 mm	0.0728 in.	
			1.88 mm	0.0740 in.	
			1.91 mm	0.0752 in.	
	1.94 mm		0.0764 in.		
	1.97 mm		0.0776 in.		
	2.00 mm		0.0787 in.		
	2.03 mm		0.0799 in.		
	2.06 mm		0.0811 in.		
	2.09 mm		0.0823 in.		
	2.12 mm		0.0835 in.		
	2.15 mm		0.0846 in.		
	2.18 mm		0.0858 in.		
	2.21 mm	0.0870 in.			
	2.24 mm	0.0882 in.			
	2.27 mm	0.0894 in.			
	2.30 mm	0.0906 in.			
	2.33 mm	0.0917 in.			
	Rear oil seal drive in depth	1.0 mm	0.039 in.		

Specifications (Cont'd)

Rear differential	Drive pinion bearing preload (at starting)		
		New bearing	13 — 20 kg-cm 11.3 — 17.4 in.-lb 1.3 — 2.0 N·m
		Reused bearing	7 — 10 kg-cm 6.1 — 8.7 in.-lb 0.7 — 1.0 N·m
	Total preload (at starting)		Add drive pinion bearing preload
	2 pinion and LSD types	4 — 6 kg-cm 3.5 — 5.2 in.-lb 0.4 — 0.6 N·m	
	w/ Differential lock	3 — 7 kg-cm 2.6 — 6.1 in.-lb 0.3 — 0.7 N·m	
	Drive pinion to ring gear backlash	0.15 — 0.20 mm	0.0059 — 0.0079 in.
	Pinion gear to side gear backlash		
	Ex. LSD type	0.02 — 0.20 mm	0.0008 — 0.0079 in.
	LSD type	0.02 — 0.24 mm	0.0008 — 0.0094 in.
	Ring gear runout	Limit	0.10 mm 0.0039 in.
	Companion flange deviation	Limit	
		Radial	0.10 mm 0.0039 in.
		Lateral	0.10 mm 0.0039 in.
	Side gear thrust washer thickness		
	Ex. LSD type	1.60 mm 0.0630 in.	
		1.75 mm 0.0689 in.	
		1.90 mm 0.0748 in.	
		2.05 mm 0.0807 in.	
	LSD type	0.20 mm 0.0079 in.	
		0.25 mm 0.0098 in.	
		0.30 mm 0.0118 in.	
		0.35 mm 0.0138 in.	
	Drive pinion adjusting plate washer thickness	1.05 mm 0.0413 in.	
		1.10 mm 0.0433 in.	
		1.15 mm 0.0453 in.	
		1.20 mm 0.0472 in.	
		1.25 mm 0.0492 in.	
		1.30 mm 0.0512 in.	
		1.35 mm 0.0531 in.	
		1.40 mm 0.0551 in.	
		1.45 mm 0.0571 in.	
		1.50 mm 0.0591 in.	
		1.55 mm 0.0610 in.	
	Side bearing adjusting plate thickness		
	(w/ Differential lock only)	2.67 mm 0.1051 in.	
		2.70 mm 0.1063 in.	
		2.73 mm 0.1075 in.	
		2.76 mm 0.1087 in.	
		2.79 mm 0.1098 in.	
		2.82 mm 0.1110 in.	
		2.85 mm 0.1122 in.	
		2.88 mm 0.1134 in.	
		2.91 mm 0.1146 in.	
		2.94 mm 0.1157 in.	
		2.97 mm 0.1169 in.	
		3.00 mm 0.1181 in.	
		3.03 mm 0.1193 in.	
		3.06 mm 0.1205 in.	
		3.09 mm 0.1217 in.	
		3.12 mm 0.1228 in.	
		3.15 mm 0.1240 in.	
		3.18 mm 0.1252 in.	
		3.21 mm 0.1264 in.	
		3.24 mm 0.1276 in.	
		3.27 mm 0.1287 in.	
		3.30 mm 0.1299 in.	
		3.33 mm 0.1311 in.	
	Front oil seal drive in depth	1.0 mm 0.039 in.	

Specifications (Cont'd)

Front				
Free wheeling hub ring oil clearance	0.3 mm		0.012 in.	
Wheel bearing preload (starting) (rotating load at hub bolt)	2.8 – 5.7 kg	6.2 – 12.6 lb	27 – 56 N	
Steering knuckle bearing preload (rotating load at knuckle arm end)	2.5 – 4.5 kg	5.6 – 12.3 lb	25 – 44 N	
Rear				
Axle shaft lateral runout	0.8 mm		0.031 in.	
Hub axial play (w/ Full-floating type)	Less than 0.1 mm (0.004 in.)			
Wheel bearing preload	0.6 – 1.4 kg	1.3 – 7.2 lb	6 – 32 N	
Axle housing and lock nut distance	-0.2 – 0.9 mm		-0.008 – 0.035 in.	

Torque Specifications

Front axle and suspension	Part tightened	kg-cm	ft-lb	N·m
	Knuckle stopper bolt	450	33	44
	Free wheeling hub body × Axle hub	360	26	59
	Free wheeling hub cover × Free wheeling hub body	100	7	10
	Axle carrier × Brake tube	155	11	15
	Axle carrier × Disc brake cylinder	1,250	90	123
	Axle hub × Flange	360	26	35
	Hub bearing adjusting nut	600	43	59
	Steering knuckle × Bearing cap	980	71	96
	Steering knuckle × Knuckle arm	980	71	96
	Steering knuckle × Oil seal retainer	55	48 in.-lb	5.4
	Knuckle arm × Tie rod end	925	67	91
	Shock absorber × Body	700	51	69
	Shock absorber × Axle housing	700	51	69
	Lateral control rod × Axle housing	1,750	127	171
	Lateral control rod × Frame	1,750	127	171
	Leading arm × Axle housing	1,750	127	171
	Leading arm × Frame	1,750	127	171
	Stabilizer bar × Axle housing	260	19	25
	Stabilizer bar bracket mounting bolt	185	13	18
	Stabilizer bar bracket × Frame	185	13	18
	Hub nut	1,500	108	147
Front differential	Propeller shaft × Companion flange	750	54	74
	Drive pinion × Companion flange	2,000 – 3,500	145 – 253	196 – 343
	Ring gear × Differential case	985	71	97
	Side bearing cap × Differential carrier	800	58	78
	Differential carrier × Axle housing	250	18	25
	Differential LH case × RH case	480	35	47
	Differential lock shaft retainer	240	17	24
	Differential lock screw plug	220	16	22
	Differential lock indicator switch	410	30	40
	Differential lock actuator	270	20	26

Specifications (Cont'd)

Rear axle and suspension	Part tightened	kg-cm	ft-lb	N·m
	Differential cover × Axle housing	130	9	13
	Differential cover × Parking brake cable clamp	130	9	13
	Differential cover × LSPV shackle bracket	195	14	19
	Differential pinion shaft pin	275	20	27
	Axle shaft × Axle hub	340	25	33
	Axle housing × Backing plate	1,250	90	123
	Bearing lock nut	600	43	59
	Shock absorber × Shock absorber bracket	700	51	69
	Shock absorber bracket × Frame	510	37	50
	Shock absorber × Axle housing	650	47	64
	Spring bumper × Frame	155	11	17
	Lateral control rod × Frame	1,800	130	177
	Lateral control rod × Axle housing	2,500	181	245
	Upper control arm × Axle housing	1,800	130	177
	Upper control arm × Frame	1,800	130	177
	Lower control arm × Axle housing	1,800	130	177
	Lower control arm × Frame	1,800	130	177
	Stabilizer bar × Axle housing	185	13	18
	Stabilizer bar × Stabilizer bar clamp	260	19	25
	Stabilizer bar clamp × Frame	150	11	15
	Hub nut	1,500	108	147
Rear differential	Propeller shaft × Companion flange	900	65	88
	Drive pinion × Companion flange	2,500 – 4,500	181 – 325	245 – 441
	Ring gear × Differential case	1,125	81	110
	Side bearing cap × Differential carrier			
	(2 pinion and LSD types)	800	58	78
	(w/ Differential lock)	1,150	83	113
	Differential carrier × Axle housing	475	34	47
	Differential LH case × RH case	480	35	47
	Pinion shaft pin (2 pinion type)	275	18	25
	Differential case × Case cover	590	43	58
	Differential lock shift fork set bolt	200	14	20
	Differential lock actuator	240	17	24
	Differential lock cover	185	13	18
	Differential lock indicator switch	410	30	40

BRAKE SYSTEM**Specifications**

Brake pedal	Pedal height (from asphalt sheet)		161 – 171 mm	6.34 – 6.73 in.
	Pedal freeplay		3 – 6 mm	0.12 – 0.24 in.
	Pedal reserve distance at 50 kg (110.2 lb, 490 N)		More than 59 mm (2.32 in.)	
Brake booster	Booster push rod to piston clearance at Idling vacuum w/ SST		0.1 – 0.5 mm 0 mm	0.004 – 0.020 in. 0 in.
Vacuum pump	Blade	Height	16.5 mm	0.5433 in.
		Width	4.95 mm	0.2343 in.
		Length	44.96 mm	1.5740 in.
	Rotation play		1.0 mm	0.039 in.
Front brake	Pad thickness (Ex. Australia) (Australia)	STD	9.5 mm	0.374 in.
		Limit	1.0 mm	0.039 in.
	Disc thickness	Limit	4.0 mm	0.157 in.
		STD	25.0 mm	0.984 in.
	Disc runout	Limit	23.0 mm	0.906 in.
		Limit	0.15 mm	0.0059 in.
Rear brake (Drum)	Drum inside diameter	STD	295.0 mm	11.614 in.
		Limit	297.0 mm	11.693 in.
	Lining thickness	STD	6.5 mm	0.256 in.
		Limit	1.5 mm	0.059 in.
Rear brake (Disc)	Pad thickness	STD	9.0 mm	0.394 in.
		Limit	1.0 mm	0.039 in.
	Disc thickness	STD	18.0 mm	0.710 in.
		Limit	16.0 mm	0.630 in.
Disc runout	Limit	0.09 mm	0.0035 in.	
Parking brake	Rear disc inner diameter	STD	210 mm	8.27 in.
		Limit	211 mm	8.31 in.
	Lining thickness	STD	4.0 mm	0.157 in.
		Limit	1.0 mm	0.039 in.
	Lever travel at 20 kg (44.1 lb, 196 N)		7 – 9 clicks	
	Clearance between rear shoe and lever		Less than 0.35 mm (0.0138 in.)	
	Adjusting shim thickness		0.3 mm	0.012 in.
		0.6 mm	0.024 in.	
		0.9 mm	0.035 in.	

Torque Specifications

Part tightened	kg-cm	ft-lb	N·m
Bleeder plug	110	8	11
Piston stopper bolt × Master cylinder	100	7	10
Outlet plug × Master cylinder	450	33	44
Reservoir set bolt × Master cylinder	250	18	25
Master cylinder × Brake booster	130	9	13
Brake tube union nut	155	11	15
Brake booster × Pedal bracket	130	9	13
Brake booster clevis lock nut	375	27	37
Vacuum pump × Check valve	750	54	74
Vacuum pump × Engine	400	29	39
Vacuum pump end cover × Casing	80	69 in.-lb	7.8
Vacuum pump gear × Rotor shaft	1,125	81	110
Vacuum pump union bolt	140	10	14
Front brake wheel cylinder × Backing plate	185	13	18
Front brake tube clamp	80	69 in.-lb	7.8
Front disc × Front axle hub	475	34	47
Front disc brake cylinder × Steering knuckle	1,250	90	123
Drum brake backing plate × Rear axle housing	1,250	90	123
Parking brake bellcrank bracket × Racking plate	130	9	13
Rear brake wheel cylinder × Backing plate	100	7	10
Rear disc brake torque plate × Axle carrier	475	34	47
Rear disc brake cylinder installation bolt	255	18	25
LSP & BV bracket × Frame	195	14	19
LSP & BV × LSP & BV bracket	130	9	13
LSP & BV spring × LSP & BV bracket	185	13	18
LSP & BV spring × Shackle No.1	185	13	18
LSP & BV shackle lock nut	250	18	25
LSP & BV shackle × Shackle bracket	130	9	13
LSP & BV shackle bracket × Rear axle housing	195	14	19

STEERING

Specifications

Steering column	Steering wheel freeplay Pawl stopper	Maximum	30 mm	1.18 in.		
		Mark				
		1 or A	12.65 – 12.75 mm	0.4980 – 0.5020 in.		
		2 or B	12.55 – 12.65 mm	0.4941 – 0.4980 in.		
		3 or C	12.45 – 12.55 mm	0.4902 – 0.4941 in.		
		4 or D	12.35 – 12.45 mm	0.4862 – 0.4902 in.		
Manual gear housing	Sector shaft thrust washer thickness		1.95 mm	0.0768 in.		
			2.00 mm	0.0787 in.		
			2.05 mm	0.0807 in.		
	Sector shaft end cover bushing inside diameter	No.1	36.055 – 36.065 mm	1.4195 – 1.4199 in.		
		2	36.045 – 36.055 mm	1.4191 – 1.4195 in.		
		3	36.035 – 36.045 mm	1.4187 – 1.4191 in.		
		4	36.025 – 36.035 mm	1.4183 – 1.4187 in.		
	Worm shaft preload	at Starting	3.5 – 5 kg-cm	3.0 – 4.3 in.-lb	0.34 – 0.49 N·m	
	Total preload	at Starting	8 – 11 kg-cm	6.9 – 9.5 in.-lb	0.78 – 1.08 N·m	
	Power steering	Drive belt tension	at 10 kg (22.0 lb, 98 N)			
New belt			7 – 9.5 mm	0.28 – 0.35 in.		
		Used belt	8 – 10 mm	0.32 – 0.39 in.		
Drive belt tension		w/ SST				
		New belt	45 – 55 kg			
Used belt		20 – 35 kg				
Maximum rise of oil level			5 mm	0.20 in.		
Oil pressure at idle speed		FJ series	Minimum	80 kg/cm ²	1,138 psi	7,845 kPa
		HZJ and HDJ series	Minimum	85 kg/cm ²	1,209 psi	8,336 kPa
		Steering effort	(w/o PPS) Maximum	4 kg	8.8 lb	39 N
		(w/ PPS) Maximum	3 kg	6.6 lb	29 N	
Rotor shaft bushing oil clearance		STD	0.01 – 0.03 mm	0.0004 – 0.0012 in.		
		Maximum	0.07 mm	0.0028 in.		
Vane plate to rotor groove clearance						
		Maximum	0.028 mm	0.0011 in.		
Vane plate		Minimum height	8.1 mm	0.319 in.		
		Minimum thickness	1.797 mm	0.0707 in.		
		Minimum length	14.988 mm	0.5901 in.		
Vane plate length		Rotor and cam ring mark	None	14.996 – 14.998 mm	0.5904 – 0.5905 in.	
			1	14.994 – 14.996 mm	0.5903 – 0.5904 in.	
			2	14.992 – 14.994 mm	0.5902 – 0.5903 in.	
			3	14.990 – 14.992 mm	0.59016 – 0.59024 in.	
	4		14.988 – 14.990 mm	0.5901 – 0.5902 in.		
Flow control valve spring length	FJ series	35 – 37 mm	1.38 – 1.46 in.			
	HZJ and HDJ series	50 – 55 mm	1.97 – 2.17 in.			
Pump rotating torque		2.8 kg-cm (2.4 in.-lb, 0.3 N·m) or less				
Ball clearance	Maximum	0.15 mm	0.006 in.			
Cross shaft adjusting screw thrust clearance		0.03 – 0.05 mm	0.0012 – 0.0020 in.			
Worm gear preload	at Starting	3 – 5.5 kg-cm	2.6 – 4.8 in.-lb	0.3 – 0.5 N·m		
Total preload	at Starting	7.5 – 11 kg-cm	6.5 – 9.6 in.-lb	0.74 – 9.6 N·m		

Torque Specifications

Steering column	Part tightened	kg-cm	ft-lb	N·m	
Steering column	Steering wheel set nut	350	25	34	
	Column tube × Body	250	18	25	
	Breakaway bracket × Body	250	18	25	
	Column hole cover × Body	80	69 in.-lb	7.8	
	Main shaft × Intermediate shaft	350	25	34	
	Intermediate shaft × Worm shaft	350	25	34	
	Turn signal bracket × Upper column tube	50	43 in.-lb	4.9	
	Tilt pawl set nut	60	52 in.-lb	5.9	
	Compression spring set bolt	80	69 in.-lb	7.8	
	Tilt lever retainer set nut	150	11	15	
	Dust seal × Column hole cover	130	9	13	
Clamp × Column tube	195	14	19		
Manual gear housing	Universal joint	350	25	34	
	Gear housing × Body	1,450	105	142	
	Pitman arm × Gear housing	1,800	130	177	
	Sector shaft adjusting screw lock nut	450	33	44	
	Sector shaft end cover	1,000	72	98	
	Bleeder plug	200	14	20	
	Worm shaft adjusting screw lock nut	1,110	80	109	
Power steering (PS pump)	FJ series				
	Pressure tube	370	27	36	
	PS pump × Bracket	450	33	44	
	PS pump × Adjusting stay	400	29	39	
	Adjusting stay × Bracket	400	29	39	
	Pulley set nut	440	32	43	
	Reservoir set bolt				
		12 mm bolt	130	9	13
		14 mm bolt	420	30	41
	Pressure port union	700	51	69	
	HZJ and HDJ series				
	Union bolt	450	33	44	
	PS pump × Engine	370	27	36	
	Return tube	80	69 in.-lb	7.8	
	Front housing × Rear housing	425	31	42	
Drive gear lock nut	750	54	74		
Valve lock screw	650	47	64		
Power steering (Gear housing)	Pressure and return tube	450	33	44	
	Universal joint	350	25	34	
	Gear housing × Body	1,450	105	142	
	Gear housing × Pitman arm	1,800	130	177	
	Cross shaft adjusting screw set nut	470	34	46	
	Cross shaft end cover lock bolt	620	45	61	
	Worm gear valve body set bolt	620	45	61	
	Plunger guide nut	205	15	20	
	Solenoid valve × Gear housing	130	9	13	
Steering linkage	Pitman arm × Relay rod	925	67	91	
	Relay rod × Steering damper	750	54	74	
	Steering damper × Damper hinge	750	54	74	
	Damper hinge × Body	400	29	39	
	Relay rod × Knuckle arm	925	67	91	
	Tie rod × Knuckle arm	925	67	91	
	Tie or relay rod clamp	375	27	38	

BODY**Torque Specifications**

Part tightened	kg-cm	ft-lb	N·m
SEAT			
Front Seat			
Set adjuster × Body	400	29	39
Second Seat			
Seat hinge × Body	400	29	39
Reclining seat adjuster × Seat cushion	530	38	52
Seat inner support × Seat cushion	420	30	41
Third Seat			
Inner leg × Seat cushion	185	13	18
Striker bar × Body	185	13	18
Outer lock × Seat cushion	400	29	39
Seat adjuster × Seat back (Parallel type)	530	38	52
Seat frame × Body	185	13	18
SEAT BELT			
Seat belt anchor × Body	440	32	43
SIDE STEP			
Step × Bracket	55	48 in.-lb	5.4
Bracket × Body	130	9	13
SPARE TIRE CARRIER			
Carrier × Body	290	21	28
Carrier × Body	185	13	18
Bracket × Body	120	7	12
FUEL TANK			
Fuel sender gauge set screw	40	35 in.-lb	3.9
Fuel tank breather set screw	15	13 in.-lb	1.5
Fuel tank filler pipe lower set screw	40	35 in.-lb	3.9
Fuel tank front bracket × Body	400	29	39
Drain plug	65	56 in.-lb	6.4

WINCH (Mechanical Winch)**Specifications**

Power take-off	Gear bushing bore	STD	20.04 — 20.08 mm	0.7890 — 0.7906 in.
		Maximum	20.08 mm	0.7906 in.
	Input gear shaft Diameter	STD	19.987 — 20.000 mm	0.7869 — 0.7874 in.
Drive shaft	Runout	Maximum	0.7 mm	0.028 in.
	Spider Axial play		0.15 mm	0.0059 in.
Winch	Gear case bore	STD A	90.000 — 90.035 mm	3.5433 — 3.5447 in.
		B	75.000 — 75.030 mm	2.9528 — 2.9539 in.
		Maximum A	90.3 mm	3.555 in.
		B	75.3 mm	2.965 in.
	Gear case cover bore	STD	65.000 — 65.030 mm	2.5591 — 2.5602 in.
		Maximum	65.3 mm	2.571 in.
	End bracket bore	STD	75.000 — 75.030 mm	2.9528 — 2.9539 in.
		Maximum	75.2 mm	2.961 in.
	Wire diameter	Minimum	7.5 mm	0.295 in.
	Adjusting shim thickness			0.228 mm
			0.5 mm	0.020 in.
			1.0 mm	0.039 in.

Torque Specifications

Part tightened	kg-cm	ft-lb	N·m
P.T.O case × Shift lock ball plug	190	14	19
P.T.O case × Lock plate	120	9	12
P.T.O case × Shift fork shaft plug	250	18	25
P.T.O case × P.T.O cover	75	65 in.-lb	7.4
P.T.O case × Bearing retainer	185	13	18
Companion flange × Output shaft	850	62	83
Companion flange × Universal joint	330	24	32
P.T.O filler plug	380	28	37
P.T.O drain plug	380	28	37
Shift outer lever × Lever lock pin	65	56 in.-lb	6.4
Pillow block × Bracket	360	26	35
Bumper × Frame	400	29	39
Bumper × Body	130	9	13
Front base member × Frame	400	29	39
Front base member × Winch roller bracket	380	27	37
Front base member × Lever shift lock plate	120	9	12
Winch base × Frame	380	27	37
Wire lock × Wire lock plate	120	9	12
Winch gear case × Worm bearing retainer	250	18	25
Winch breather plug	200	15	20
Winch drain plug	175	13	17
Winch filler plug	175	13	17
Winch gear case cover	115	8	11
Winch gear case cover × Winch gear case	120	9	12
Winch gear case cover × Shift lock lever	120	9	12

WINCH (Electric Winch)**Specifications**

Winch	Spacer No.1 thickness		STD	1.4 mm	0.0551 in.	
			Minimum	1.0 mm	0.0394 in.	
	Drum bore		STD	64.20 mm	2.5276 in.	
			Maximum	64.36 mm	2.5339 in.	
	Outer clutch	Bore	STD	12.00 mm	0.4724 in.	
			Maximum	12.03 mm	0.4736 in.	
			STD	27.77 mm	1.0933 in.	
	Outer disc thickness		STD	1.60 mm	0.0630 in.	
			Minimum	1.50 mm	0.0591 in.	
	Inner disc thickness		STD	2.30 mm	0.0906 in.	
			Minimum	2.15 mm	0.0846 in.	
	Drum spacer No.2 thickness		STD	1.4 mm	0.0551 in.	
			Minimum	1.0 mm	0.0394 in.	
	Input shaft thrust washer thickness		STD	2.00 mm	0.0787 in.	
			Minimum	1.80 mm	0.0709 in.	
	Clutch thrust washer thickness		STD	1.25 mm	0.0492 in.	
			Minimum	1.00 mm	0.0394 in.	
	Output shaft	Bore	STD	12.00 mm	0.4724 in.	
			Maximum	12.03 mm	0.4736 in.	
			STD	28.00 mm	1.1024 in.	
			Maximum	27.90 mm	1.0984 in.	
	Brake case bore		STD	27.76 mm	1.0929 in.	
			Maximum	27.82 mm	1.0953 in.	
Drive shaft diameter		Minimum A	11.86 mm	0.4669 in.		
		B	11.70 mm	0.4606 in.		
		C	11.95 mm	0.4705 in.		
Clutch input shaft diameter		STD	11.95 mm	0.4705 in.		
Gear case cover bore		STD	12.00 mm	0.4724 in.		
		Maximum	12.15 mm	0.4783 in.		
Planetary gear No.3 bore		STD	28.00 mm	1.1024 in.		
		Maximum	28.05 mm	1.1043 in.		
Wire diameter		Minimum	7.5 mm	0.295 in.		
Winch motor	Commutator	Circle runout	STD	0.05 mm	0.0020 in.	
			Maximum	0.2mm	0.008 in.	
			Diameter	STD	43 mm	1.69 in.
				Minimum	41 mm	1.61 in.
			Undercut depth	STD	0.5 — 0.8 mm	0.020 — 0.031 in.
				Minimum	0.2 mm	0.008 in.
	Brush	Length	STD	22 mm	0.87 in.	
			Minimum	15 mm	0.59 in.	

Torque Specifications

Part tightened	kg-cm	ft-lb	N·m
Frame × Front base member	400	29	39
Frame × Winch base	400	29	39
Winch base × Winch brake case	600	43	59
Winch base × Winch gear case	330	24	32
Front base member × Winch brake case	220	16	22
Front base member × Winch roller bracket	290	21	28
Winch brake case × Winch motor	160	12	16
Winch drum × Winch wire	10	9 in.-lb	1.0
Drain plug	175	13	17
Handle bolt	45	35 in.-lb	4.4
Winch gear case × gear case cover	90	78 in.-lb	8.8
Motor brush × brush holder	35	30 in.-lb	3.4
Commutator end frame × Yoke	78	68 in.-lb	7.6
Magnet switch No.1	95	82 in.-lb	9.3
Magnet switch No.1 × Body	85	74 in.-lb	8.3
Magnet switch No.2 base × Magnet switch	55	48 in.-lb	5.4
Magnet switch No.2 × Wire harness (screw)	18	16 in.-lb	2.0
Magnet switch No.2 × Wire harness (bolt)	95	82 in.-lb	9.3
Magnet switch No.2 × Terminal plate	95	82 in.-lb	9.3
Magnet switch No.2 assembly × Winch motor	50	43 in.-lb	4.9
Magnet switch No.2 assembly × Magnet switch cover	15	13 in.-lb	1.5

LUBRICANT









Item	Capacity			Classification		
	Liters	US qts	Imp.qts			
Manual transmission oil				API GL-4 or GL-5		
H140F	2.7	2.8	2.4	SAE 75W-90		
H150F, H151F	2.6	2.7	2.3			
Automatic transmission fluid				ATF DEXRON® II		
Dry fill						
w/o Oil cooler	15.0	15.9	13.2			
w/ Oil cooler	15.4	16.3	13.6			
Drain and refill	6.0	6.3	5.3			
Transfer oil	1.3	1.4	1.1	API GL-4 or GL-5, SAE 75W-90		
Differential oil	Front			API GL-5		
	2 pinion type	2.8	2.9	2.5	Above – 18°C (0°F)	
	w/ Differential lock	2.65	2.8	2.3	SAE 90	
					Below – 18°C (0°F)	
				SAE 80W or 80W-90		
	Rear	w/o LSD	3.25	3.4	2.9	API GL-5
						Above – 18°C (0°F)
						SAE 90
						Below – 18°C (0°F)
						SAE 80W or 80W-90
		w/ LSD	3.25	3.4	2.9	API GL-5 for LSD
						Above – 18°C (0°F)
						SAE 90
						Below – 18°C (0°F)
						SAE 80W or 80W-90
Power steering fluid				ATF DEXRON® II		
Gear box	0.51	0.54	0.45			
Total	0.75	0.79	0.66			
Steering gear box oil	0.64	0.68	0.56	API GL-4, SAE 90		
Brake fluid	—	—	—	SAE J1703 or FMVSS No.116 DOT3		
P.T.O oil	0.1	0.1	0.09	API GL-4 or GL-5, SAE 75W-90		
Mechanical winch fluid	0.3	0.32	0.26	API GL-4, SAE 85W-90		
Electric winch fluid	0.9	0.95	0.79	ATF Type F		

STANDARD BOLT TORQUE SPECIFICATIONS

	Page
STANDARD BOLT TORQUE SPECIFICATIONS.	B-2

STANDARD BOLT TORQUE SPECIFICATIONS

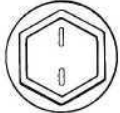
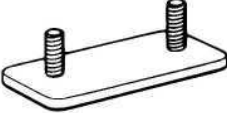
HOW TO DETERMINE BOLT STRENGTH

	Mark	Class		Mark	Class
Hexagon head bolt	 <p>Bolt head No.</p> <p>4— 4T 5— 5T 6— 6T 7— 7T 8— 8T 9— 9T 10— 10T 11— 11T</p>		Stud bolt	 <p>No mark</p>	4T
	 <p>No mark</p>	4T			
Hexagon flange bolt w/ washer hexagon bolt	 <p>No mark</p>	4T	Welded bolt	 <p>Grooved</p>	6T
Hexagon head bolt	 <p>Two protruding lines</p>	5T			
Hexagon flange bolt w/ washer hexagon bolt	 <p>Two protruding lines</p>	6T		4T	
Hexagon head bolt	 <p>Three protruding lines</p>	7T			
Hexagon head bolt	 <p>Four protruding lines</p>	8T			











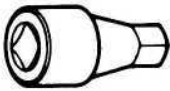
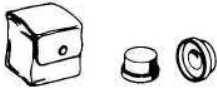

SPECIFIED TORQUE FOR STANDARD BOLTS

Class	Diameter mm	Pitch mm	Specified torque					
			Hexagon head bolt			Hexagon flange bolt		
			kg-cm	ft-lb	N-m	kg-cm	ft-lb	N-m
4T	6	1	55	48 in.-lb	5	60	52 in.-lb	6
	8	1.25	130	9	12.5	145	10	14
	10	1.25	260	19	26	290	21	29
	12	1.25	480	35	47	540	39	53
	14	1.5	760	55	74	850	61	84
	16	1.5	1,150	83	115	—	—	—
5T	6	1	65	56 in.-lb	6.5	75	65 in.-lb	7.5
	8	1.25	160	12	15.5	175	13	17.5
	10	1.25	330	24	32	360	26	36
	12	1.25	600	43	59	670	48	65
	14	1.5	930	67	91	1,050	76	100
	16	1.5	1,400	101	140	—	—	—
6T	6	1	80	69 in.-lb	8	90	78 in.-lb	9
	8	1.25	195	14	19	210	15	21
	10	1.25	400	29	39	440	32	44
	12	1.25	730	53	71	810	59	80
	14	1.5	1,100	80	110	1,250	90	125
	16	1.5	1,750	127	170	—	—	—
7T	6	1	110	8	10.5	120	9	12
	8	1.25	260	19	25	290	21	28
	10	1.25	530	38	52	590	43	58
	12	1.25	970	70	95	1,050	76	105
	14	1.5	1,500	108	145	1,700	123	165
	16	1.5	2,300	166	230	—	—	—
8T	8	1.25	300	22	29	330	24	33
	10	1.25	620	45	61	690	50	68
	12	1.25	1,100	80	110	1,250	90	120
9T	8	1.25	340	25	34	380	27	37
	10	1.25	710	51	70	790	57	78
	12	1.25	1,300	94	125	1,450	105	140
10T	8	1.25	390	28	38	430	31	42
	10	1.25	800	58	78	890	64	88
	12	1.25	1,450	105	140	1,600	116	155
11T	8	1.25	430	31	42	480	35	47
	10	1.25	890	64	87	990	72	97
	12	1.25	1,600	116	155	1,800	130	175









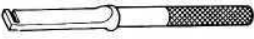

SST AND SSM

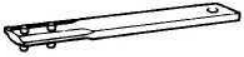
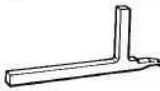
	Page
SST (SPECIAL SERVICE TOOLS).....	C-2
SSM (SPECIAL SERVICE MATERIALS).....	C-11



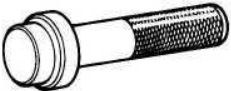









SST (SPECIAL SERVICE TOOLS) (Cont'd)

Section	Part Name	Part No.	CL	MT	AT	TF	PR	SA		BR	SR	BE	BO	Note
								Front	Rear					
Illustration														
	(09310-07010)	(Plate)		●										
	(09310-07020)	(Center Bolt)		●										
	09313-30021	Detent Ball Plug Socket						●						Straight screw plug (w/ Differential lock only)
	09315-00021	Clutch Release Bearing Remover & Replacer							●					Differential side bearing (2 pinion and LSD types)
	09316-20011	Transfer Bearing Replacer		●		●								
	09316-60010	Transmission & Transfer Bearing Replacer		●		●		●	●					
	(09316-00010)	(Replacer Pipe)		●		●		*1	*2					*1 Drive pinion bearing outer race and oil storage ring *2 Drive pinion bearing outer race
	(09316-00020)	(Replacer "A")		●		●		*1	*2					*1 Drive pinion bearing outer race and oil storage ring *2 Drive pinion bearing outer race
	(09316-00030)	(Replacer "B")				●								
	(09316-00040)	(Replacer "C")				●								
	(09316-00050)	(Replacer "D")				●		*						* Drive pinion bearing outer race
	(09316-00060)	(Replacer "E")				●								
	(09316-00070)	(Replacer "F")				●								
	09330-00021	Companion Flange Holding Tool				●		●	●					

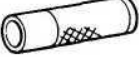

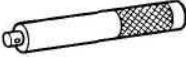









SST (SPECIAL SERVICE TOOLS) (Cont'd)

Section			CL	MT	AT	TF	PR	SA		BR	SR	BE	BO	Note
Part Name	Part No.	Illustration						Front	Rear					
	09332-25010	Universal Joint Bearing Remover & Replacer					●							
	09333-00013	Clutch Diaphragm Spring Aligner	●											
	09336-60010	Transmission Gear Remover		●										
	09504-00011	Differential Side Bearing Adjusting Nut Wrench						●	●					
	09504-22011	Differential Side Washer Remover & Replacer							●					w/ Differential lock only
	09506-30012	Differential Drive Pinion Bearing Cone Replacer						●						
	09506-35010	Differential Drive Pinion Rear Bearing Replacer							●					
	09509-25011	Rear Axle Bearing Lock Nut Wrench							●					
	09514-35011	Rear Wheel Bearing Puller							●					
	09517-36010	Rear Axle Shaft Oil Seal Replacer							●					
	09523-36010	Rear Axle Hub Guide Tool		●										Output shaft rear ball bearing
	09550-10012	Replacer Set "B"							●		●			
	(09252-10010)	(No. 1 Replacer Handle)							●					Differential side bearing (w/ Differential lock only)
	(09552-10010)	(No. 2 Replacer Handle)									●			



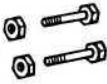
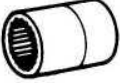









SST (SPECIAL SERVICE TOOLS) (Cont'd)

Section	Part Name	Part No.	Illustration	CL	MT	AT	TF	PR	SA		BR	SR	BE	BO	Note
									Front	Rear					
		(09608-00080)					●								
		(09608-03020)			●		●			●					
		(09608-03060)								●					
		(09608-03090)								●					
		09608-30012							●		●				
		(09608-00060)							●						
		(09608-04030)									●				
		(09608-04060)							●						
		09608-35014							●	●					
		(09608-06020)							●	●					
		(09608-06110)								●					
		(09608-06150)							●	●					
		(09608-06180)								●					
		(09608-06200)							●	●					





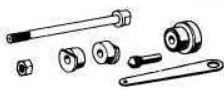
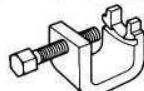









SST (SPECIAL SERVICE TOOLS) (Cont'd)

Section	Part Name	Part No.	Illustration	CL	MT	AT	TF	PR	SA		BR	SR	BE	BO	Note
									Front	Rear					
		(09608-06210)							●	●					
		09609-20011										●			
		09610-55012										●			
		09611-22012							●			●			
		09612-30012		●											
		09612-65014							●			●			
		(09612-01010)							●						Knuckle spindle bushing
		(09612-01030)										●			Manual steering
		(09612-01040)										●			Manual steering
		(09612-01050)							●						Knuckle spindle bushing
		09616-00010										●			
		09616-30020							●			●			* 1 Differential side bearing adjusting nut (w/ Differential lock only) * 2 Manual steering
		09617-60010										●			Manual steering
		09618-60010							●						









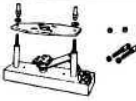

SST (SPECIAL SERVICE TOOLS) (Cont'd)

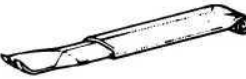
Section	Part Name	Part No.	Illustration	CL	MT	AT	TF	PR	SA		BR	SR	BE	BO	Note
									Front	Rear					
		09628-62011										●			
		09630-00012		●								●			
		(09631-00020)										●			
		(09631-00050)										●			
		(09631-00060)		●											
		(09631-00070)										●			
		(09631-00090)										●			
		(09631-00120)										●			
		(09631-00140)										●			
		09631-22020										●			
		09632-36010										●			
		09634-60013							●						
		09650-17011										●			
		09703-30010										●			

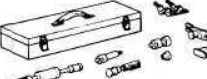
SST (SPECIAL SERVICE TOOLS) (Cont'd)

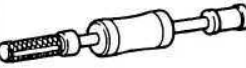
Section	Part Name	Part No.	Illustration	CL	MT	AT	TF	PR	SA		BR	SR	BE	BO	Note
									Front	Rear					
		09709-29017									●				
		09710-22041								●					
		(09710-02020)								●					
		(097104)2050								●					
		(09710-02070)								●					
		09710-30030								●					
		(09710-03180)								●					
		09717-20010									●				
		09718-00010									●				
		09718-20010									●				
		09726-40010								●	●				• Companion flange
		09727-30020								●					
		09737-00010		●							●				
		09751-36011		●						●	●				

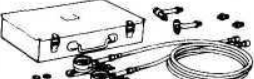
SST (SPECIAL SERVICE TOOLS) (Cont'd)

Section	Part Name	Part No.	Illustration	CL	MT	AT	TF	PR	SA		BR	SR	BE	BO	Note
									Front	Rear					
		09753-00013		●							●				
		09753-30020		●											
		09753-40010									●				
		09806-30010												●	
		09812-00010												●	
		09910-00015										●			
		(09911-00011)										●			
		(09912-00010)										●			
		09950-00020			●		●		●	●					
		09950-20017			●		●		●	●		●			
		09992-00094				●									
		09992-00241											●		Check for turbo indicator and warning system (1HD-T engine)

NOTE: For reference to SSTs for the Air Conditioning System see page AC-20.

SSM (SPECIAL SERVICE MATERIALS)

Part Name	Part No.	Sec.	Use etc.
Seal packing 1281, Three bond 1281 or equivalent	08826-00090	MT	Transmission case x Intermediate plate Transmission case x Front bearing retainer Transfer adaptor x Intermediate plate Transmission case x Shift lever control retainer
		AT	Oil pan x Transmission case
		TF	Front case x Rear case Rear case x Case cover Rear case x Rear extension housing Front case x Front extension housing Front case x Motor actuator
		SA	Differential lock shaft retainer Differential lock actuator Differential lock cover
Adhesive 1324, Three bond 1324 or equivalent	08833-00070	SA	Differential pinion shaft pins and bolts Differential cover lock set bolts Differential lock shift fork set bolt
Adhesive 1344, Three bond 1344, Loctite 242 or equivalent	08833-00080	MT	Front bearing retainer set bolts Oil pump body set bolts Shift lever control retainer set bolts
		TF	Straight screw plug Rear case set bolts (two bolts) Case cover set bolts
		SA	Differential lock shaft retainer set bolt Straight screw plug
		SR	Manual gear housing worm bearing adjusting screw and lock nut Sector shaft end cover
Dupont paste No. 4817	—	BE	Rear window defogger wire
Three cement black	08833-00030	BO	Windshield glass
Adhesive (Super special)	08850-00051	BO	Side protection moulding

NOTE: For reference to SSMs for the Air Conditioning System see page AC-20.