

TRANSFER

| | Page |
|---------------------------------------|-------|
| DESCRIPTION..... | TF-2 |
| PRECAUTIONS..... | TF-3 |
| TROUBLESHOOTING..... | TF-3 |
| (Full-Time 4WD Type Transfer) | |
| COMPONENTS..... | TF-4 |
| DISASSEMBLY OF TRANSFER..... | TF-5 |
| COMPONENT PARTS..... | TF-12 |
| Input Shaft Assembly..... | TF-12 |
| Idler Gear Assembly..... | TF-16 |
| Center Differential Assembly..... | TF-20 |
| Front Extension Housing Assembly..... | TF-29 |
| Rear Extension Housing Assembly..... | TF-33 |
| ASSEMBLY OF TRANSFER..... | TF-40 |
| (Part-Time 4WD Type Transfer) | |
| COMPONENTS..... | TF-49 |
| DISASSEMBLY OF TRANSFER..... | TF-50 |
| COMPONENT PARTS..... | TF-59 |
| Input Shaft Assembly..... | TF-59 |
| Idler Gear Assembly..... | TF-63 |
| Output Shaft Assembly..... | TF-65 |
| Front Extension Housing Assembly..... | TF-71 |
| Rear Extension Housing Assembly..... | TF-75 |
| ASSEMBLY OF TRANSFER..... | TF-79 |
| MOTOR SHIFT CONTROL SYSTEM..... | TF-89 |

TF

DESCRIPTION

TRANSFER

The transfer transmits the drive force from the transmission to the front wheels, switching between 2WD, 4WD (High) and 4WD (Low).

The specifications and cross-section diagrams are as shown.

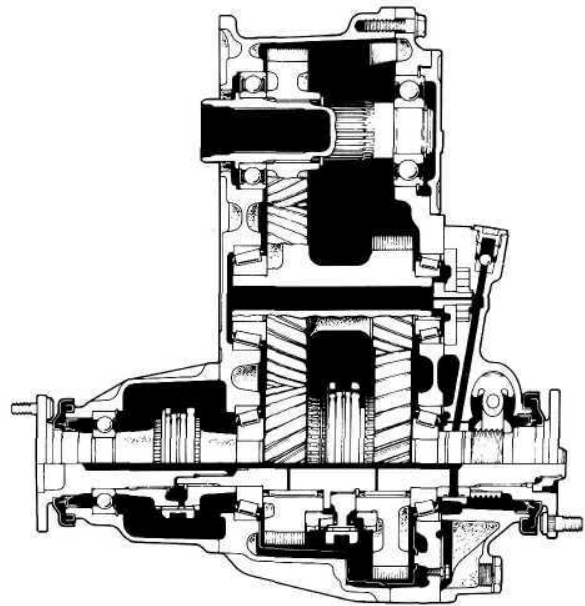
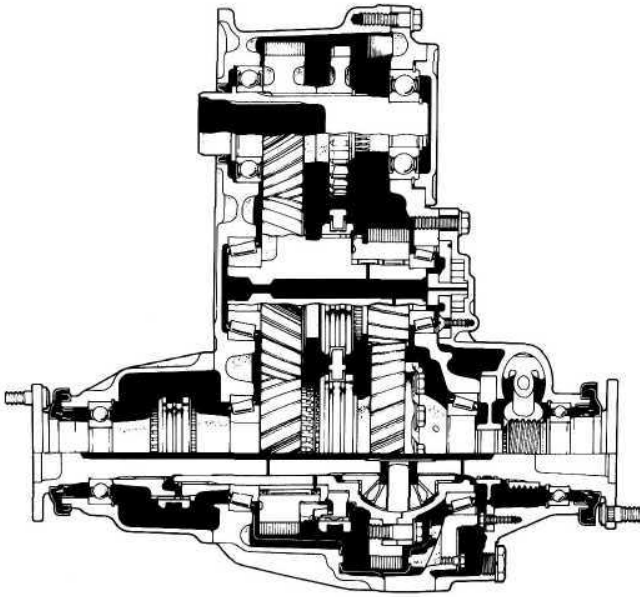

TF0106 TF0105

Specifications

| Type of Transfer | | HF2A (Full-Time) | | | | HF1A (Part-Time) | | | | |
|----------------------|------------------|--------------------------------------|-------|-------------|-------|---------------------|-----------|-------|-----------|-------|
| Type of Transmission | | H150F | H151F | A440F | A442F | H140F | H150F | H151F | A440F | A442F |
| Type of Engine | | 3F 1HZ | 1HD-T | 3F-E 1HZ | 1HD-T | 3F 1HZ | 3F 1HZ | 1HD-T | 3F 1HZ | 1HD-T |
| Gear Ratio | High Speed Range | 1.000 | | | | ← | | | | |
| | Low Speed Range | 2.488 | | | | ← | | | | |
| Oil Capacity | | 1.3 liters (1.4 US qts, 1.1 Imp.qts) | | | | ← | | | | |
| Type of oil | | API GL-4 or GL-5, SAE 75W-90 | | | | | | | | |

PRECAUTIONS

When working with FIPG material, you must observe the following.

- Using a razor blade and gasket scraper, remove all the old packing (FIPG) material from the gasket surfaces.
- Thoroughly clean all components to remove all the loose material.
- Clean both sealing surfaces with a non-residue solvent.
- Apply the seal packing in approx. 1 mm (0.04 in.) bead along the sealing surface.
- Parts must be assembled within 10 minutes of application. Otherwise, the packing (FIPG) material must be removed and reapplied.

TROUBLESHOOTING

| Problem | Possible cause | Remedy | Page |
|---------------------------------|--|---|--------------|
| Hard to shift or will not shift | Transfer faulty | Disassemble and inspect transfer | TF-48 |
| Transfer jumps out of gear | Transfer faulty | Disassemble and inspect transfer | TF-48 |
| Noise | Transfer faulty | Disassembly and inspect transfer | MT-4 |
| | Wrong oil grade Oil level low | Replace oil Add oil | MT-4 |
| Oil leakage | Oil level too high | Drain oil | MT-4 |
| | Oil seal, O-ring or gasket worn or damaged | Replace oil seal, O-ring or gasket | |
| Tight corner braking | Center differential or transfer faulty | Replace center differential or transfer | MT-4 MT-4 |

(FULL-TIME 4WD TYPE TRANSFER) COMPONENTS

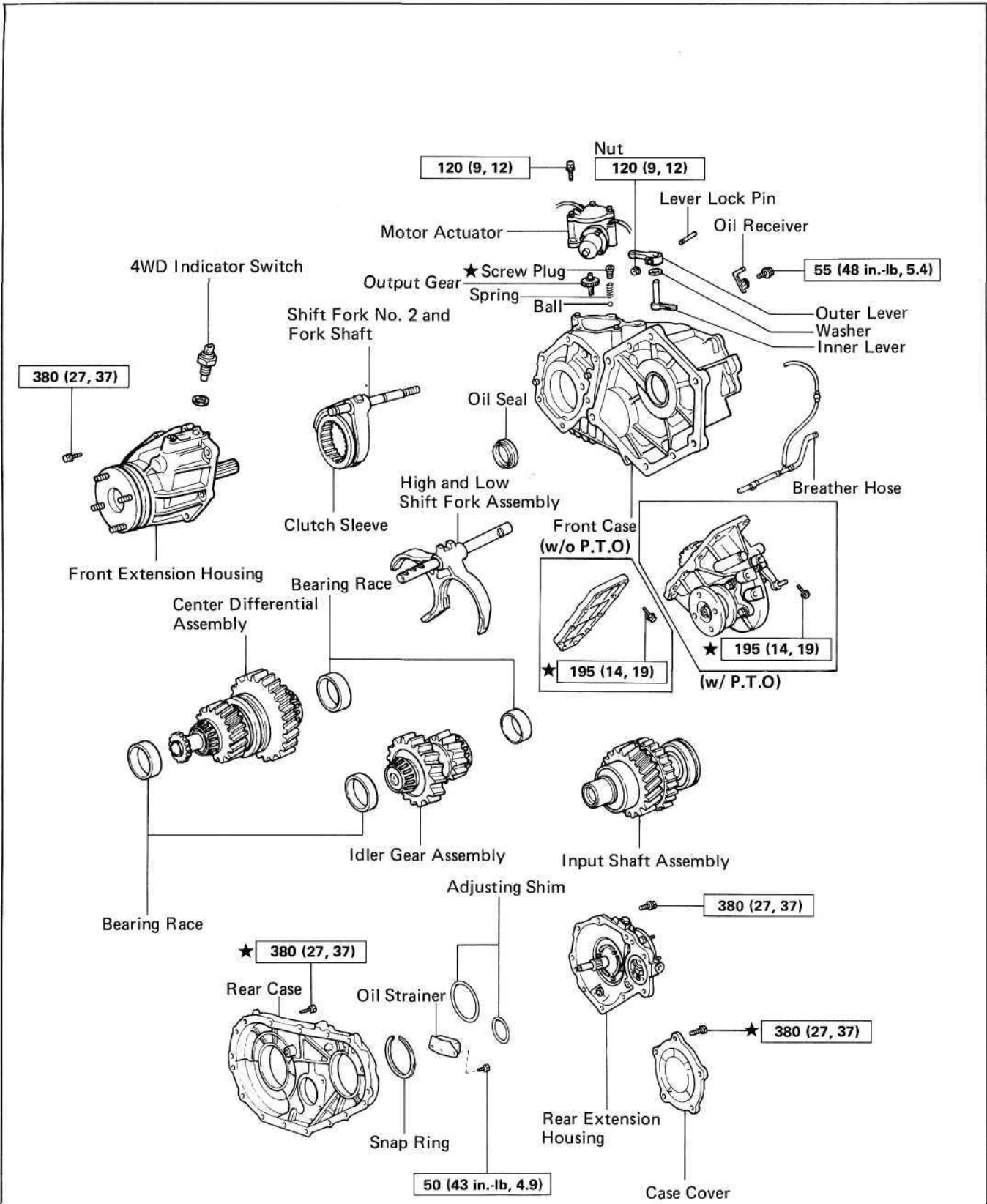

kg-cm (ft-lb, N·m) : Specified torque

★ Precoated part

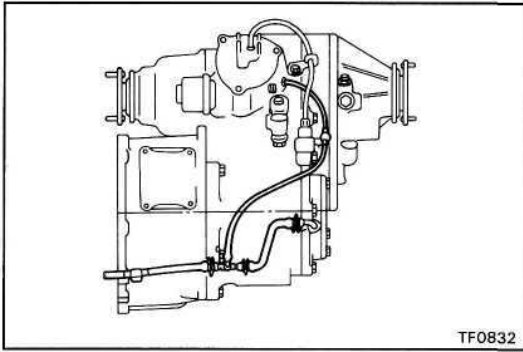

DISASSEMBLY OF TRANSFER

(See page TF-4)

1. REMOVE BREATHER HOSE

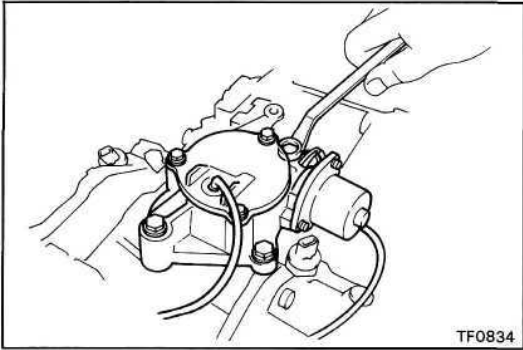

2. REMOVE MOTOR ACTUATOR

Remove the four bolts and motor actuator.

HINT: Set the motor actuator in differential lock condition.

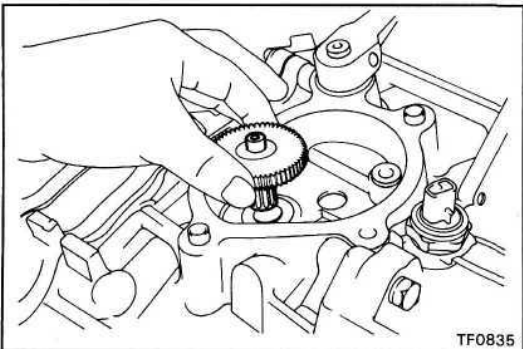

3. REMOVE OUTPUT GEAR

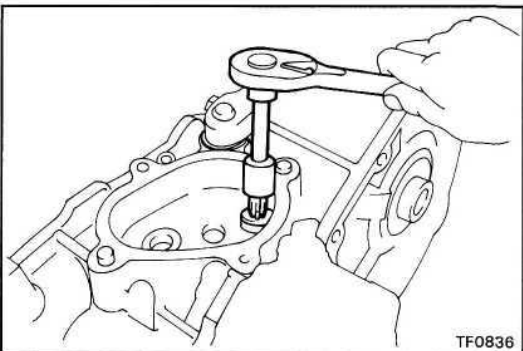

4. REMOVE SCREW PLUG, SPRING AND BALL

(a) Using a torx socket wrench, remove the screw plug.
(Torx socket wrench T40 09042-00020)

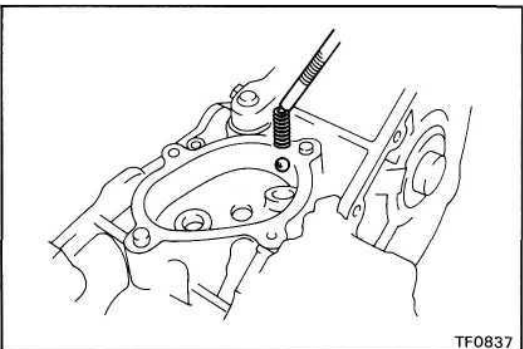

(b) Using a magnetic finger, remove the spring and ball.

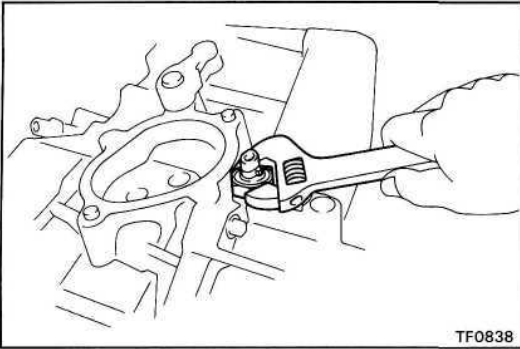

5. REMOVE 4WD INDICATOR SWITCH

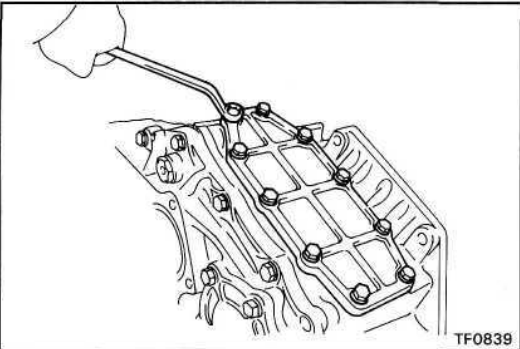

6. (w/o POWER TAKE-OFF)
REMOVE POWER TAKE-OFF COVER

Remove the ten bolts, power take-off cover and gasket.

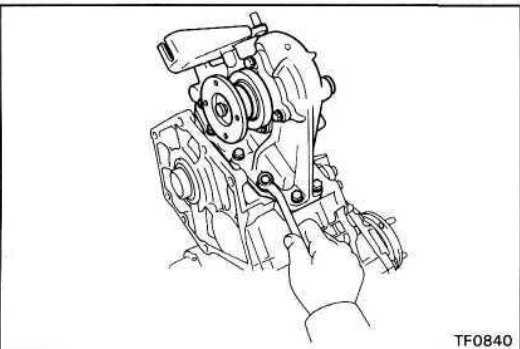

7. (w/ POWER TAKE-OFF)
REMOVE POWER TAKE-OFF CASE

Remove the ten bolts, power take-off case and gasket.

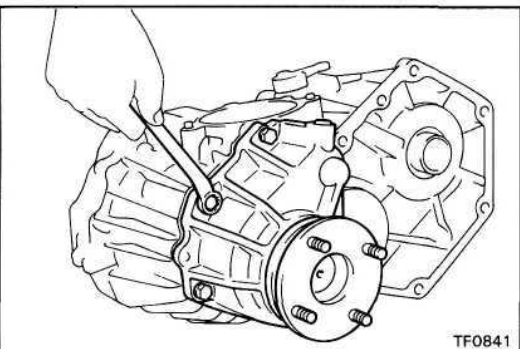

8. REMOVE FRONT EXTENSION HOUSING

(a) Remove the six bolts.

(b) If necessary, tap the front extension housing with a plastic hammer.

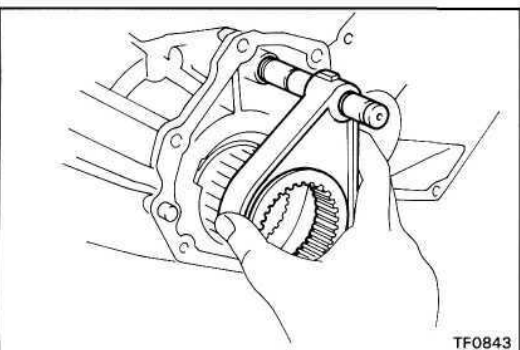

9. REMOVE CLUTCH SLEEVE, SHIFT FORK NO.2 AND FORK SHAFT

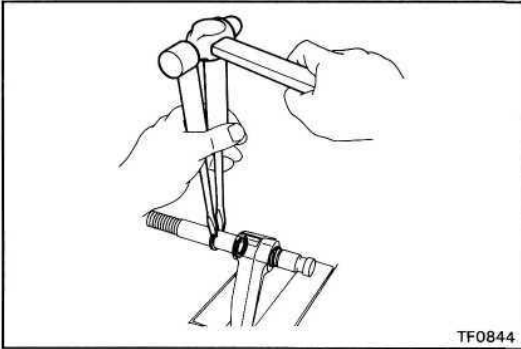
**10. SEPARATE SHIFT FORK NO.2 AND FORK SHAFT**

- (a) Using two screwdrivers and a hammer, tap out the three snap rings.
- (b) Separate the shift fork No.2 and fork shaft.

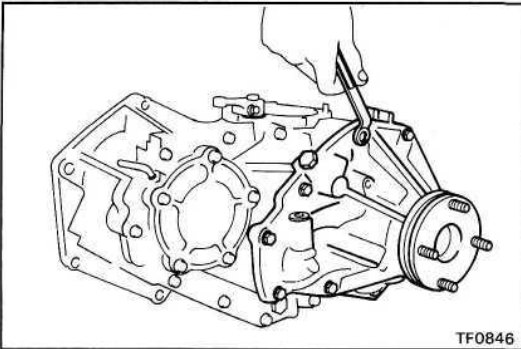
**11. REMOVE REAR EXTENSION HOUSING**

- (a) Remove the nine bolts.
- (b) If necessary, tap the rear extension housing with a plastic hammer.

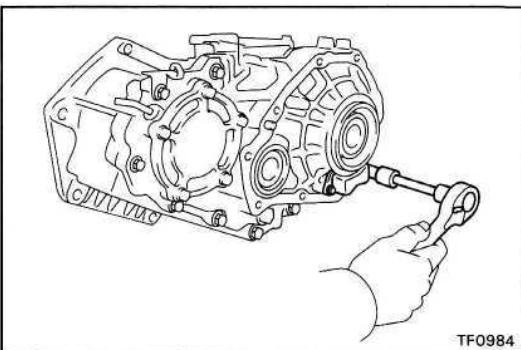
**12. REMOVE OIL STRAINER FROM REAR CASE**

Remove the two set bolts and oil strainer.

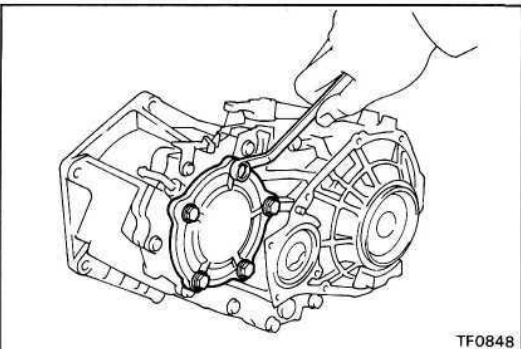
**13. REMOVE CASE COVER**

- (a) Remove the five bolts.

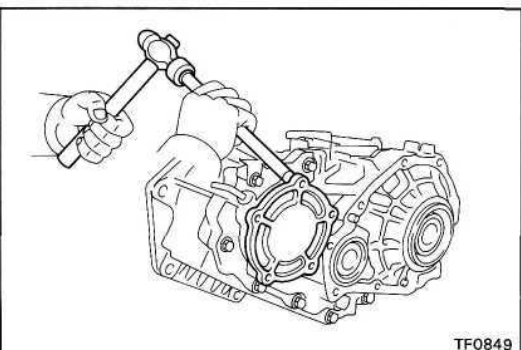

- (b) Using a brass bar and hammer, tap the case cover and remove it.

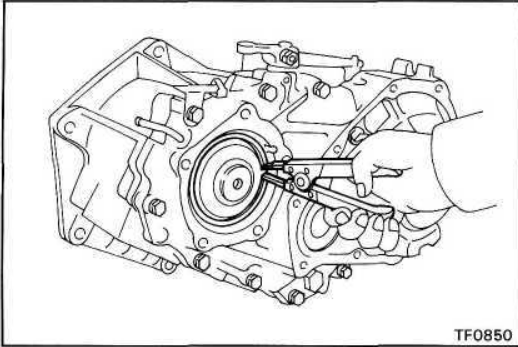

14. SEPARATE FRONT CASE AND REAR CASE

(a) Using snap ring pliers, remove the snap ring.

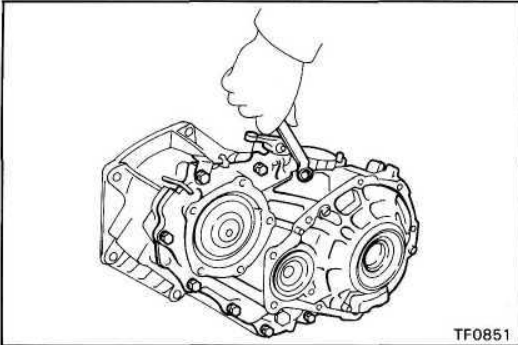

(b) Remove the eight bolts.

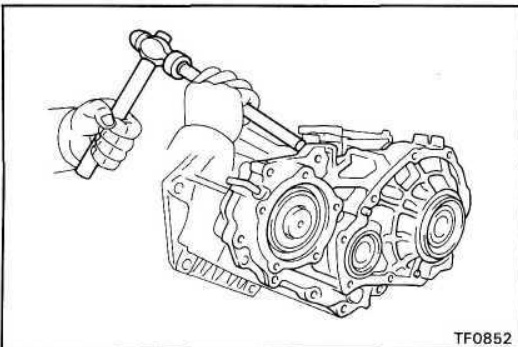

(c) Using a brass bar and hammer, tap the rear case and separate it.

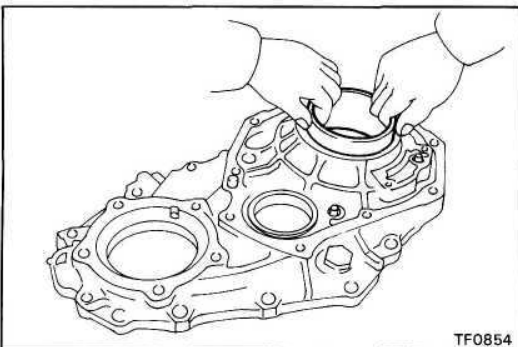

15. REMOVE TWO BEARING RACES FROM REAR CASE

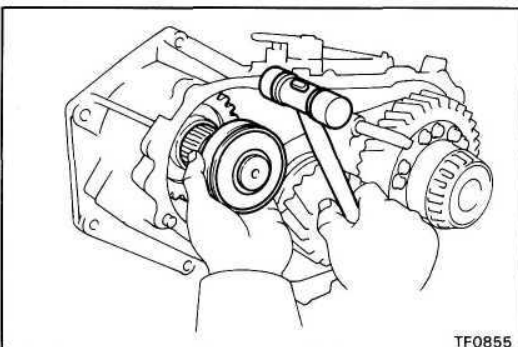

16. REMOVE INPUT SHAFT ASSEMBLY

Using a plastic hammer, remove the input shaft assembly.

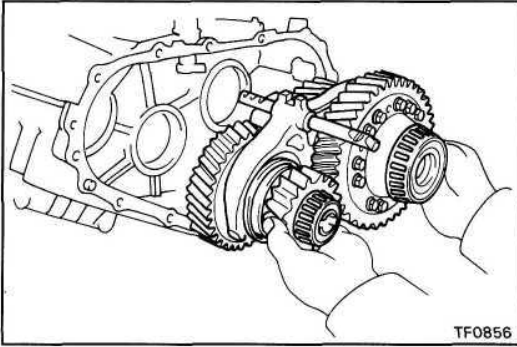

17. REMOVE IDLER GEAR ASSEMBLY, CENTER DIFFERENTIAL ASSEMBLY AND HIGH AND LOW SHIFT FORK ASSEMBLY

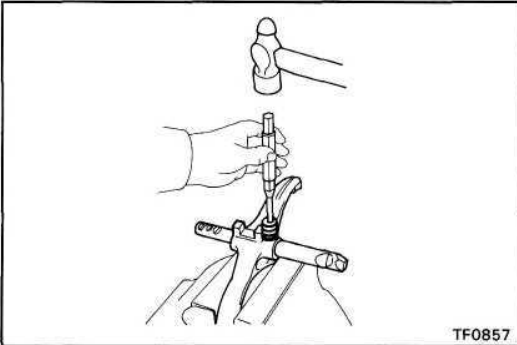

18. SEPARATE HIGH AND LOW SHIFT FORK

- (a) Using a pin punch and hammer, drive out the slotted spring pin.
- (b) Separate the high and low shift fork and fork shaft.

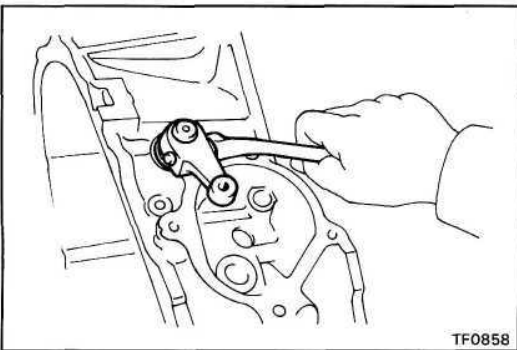

19. REMOVE SHIFT OUTER LEVER, INNER LEVER AND WASHER

- (a) Remove the nut and washer.

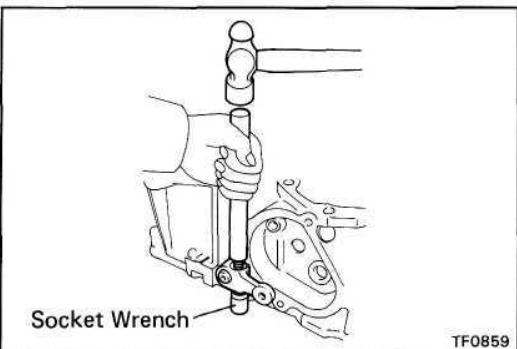

- (b) Using a brass bar, hammer and socket wrench, tap out the lever lock pin.

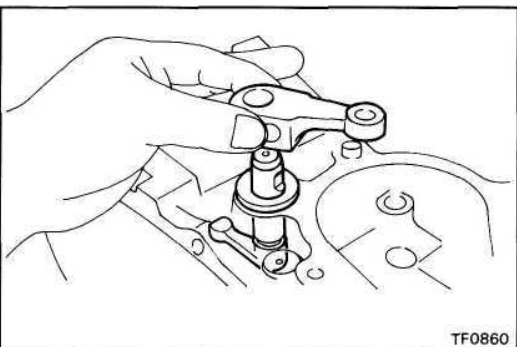

- (c) Remove the shift outer lever, inner lever and washer.

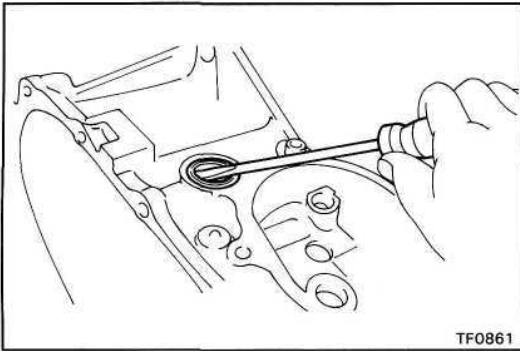
**20. IF NECESSARY, REPLACE SHIFT LEVER OIL SEAL**

(a) Using a screwdriver, pry out the oil seal.

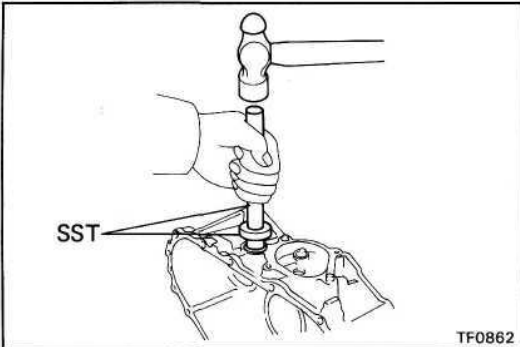

(b) Using SST and a hammer, drive in a new oil seal.
SST 09608-20012, (09608-00080, 09608-03020)

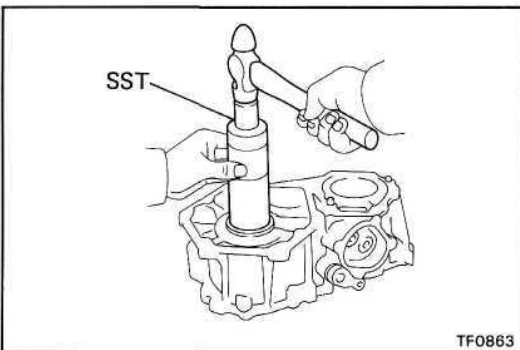
**21. IF NECESSARY, REPLACE INPUT SHAFT OIL SEAL**

(a) Using SST and a hammer, drive out the oil seal.
SST 09316-60010 (09316-00010)

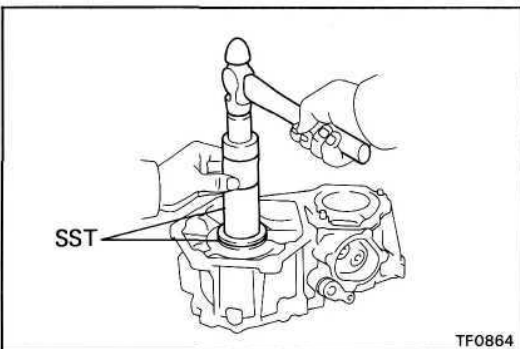

(b) Using SST and a hammer, drive in a new oil seal.
SST 09316-60010 (09316-00010, 09316-00030)

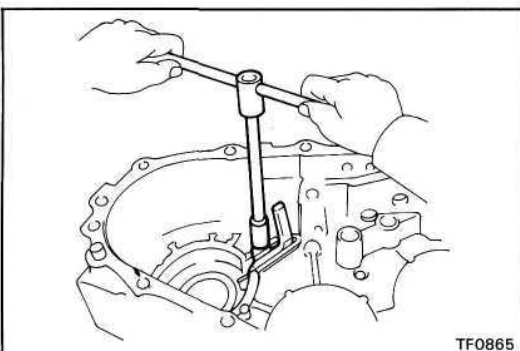
**22. REMOVE OIL RECEIVER FROM FRONT CASE**

Remove the set bolt and oil receiver.

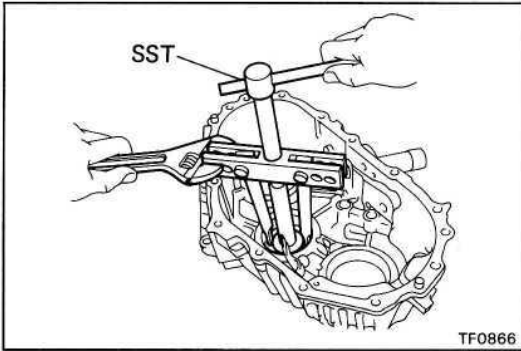
**23. REMOVE TWO BEARING RACES FROM FRONT CASE**

(a) Using SST, remove the bearing race.

SST 09950-20017

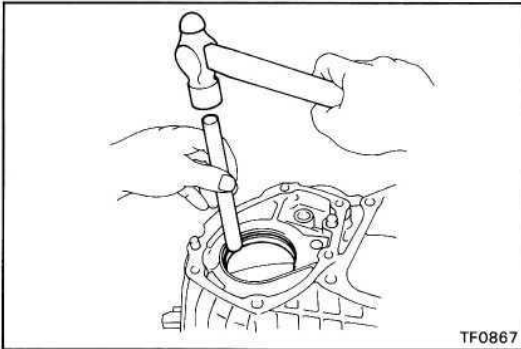

(b) Using a brass bar and hammer, remove the bearing race.

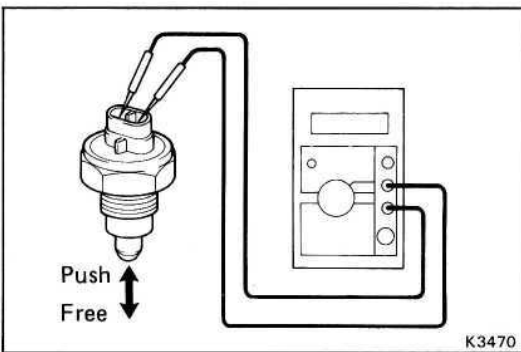
**24. INSPECTION OF 4WD INDICATOR SWITCH**

Check that there is continuity between terminals as shown.

| Switch Position | Specified |
|-----------------|---------------|
| Push | Continuity |
| Free | No continuity |

If operation is not as specified, replace the switch.

COMPONENT PARTS

Input Shaft Assembly

COMPONENTS

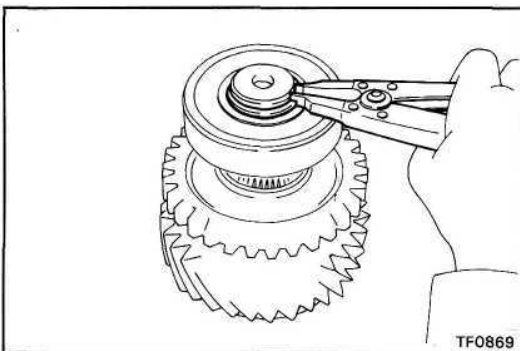
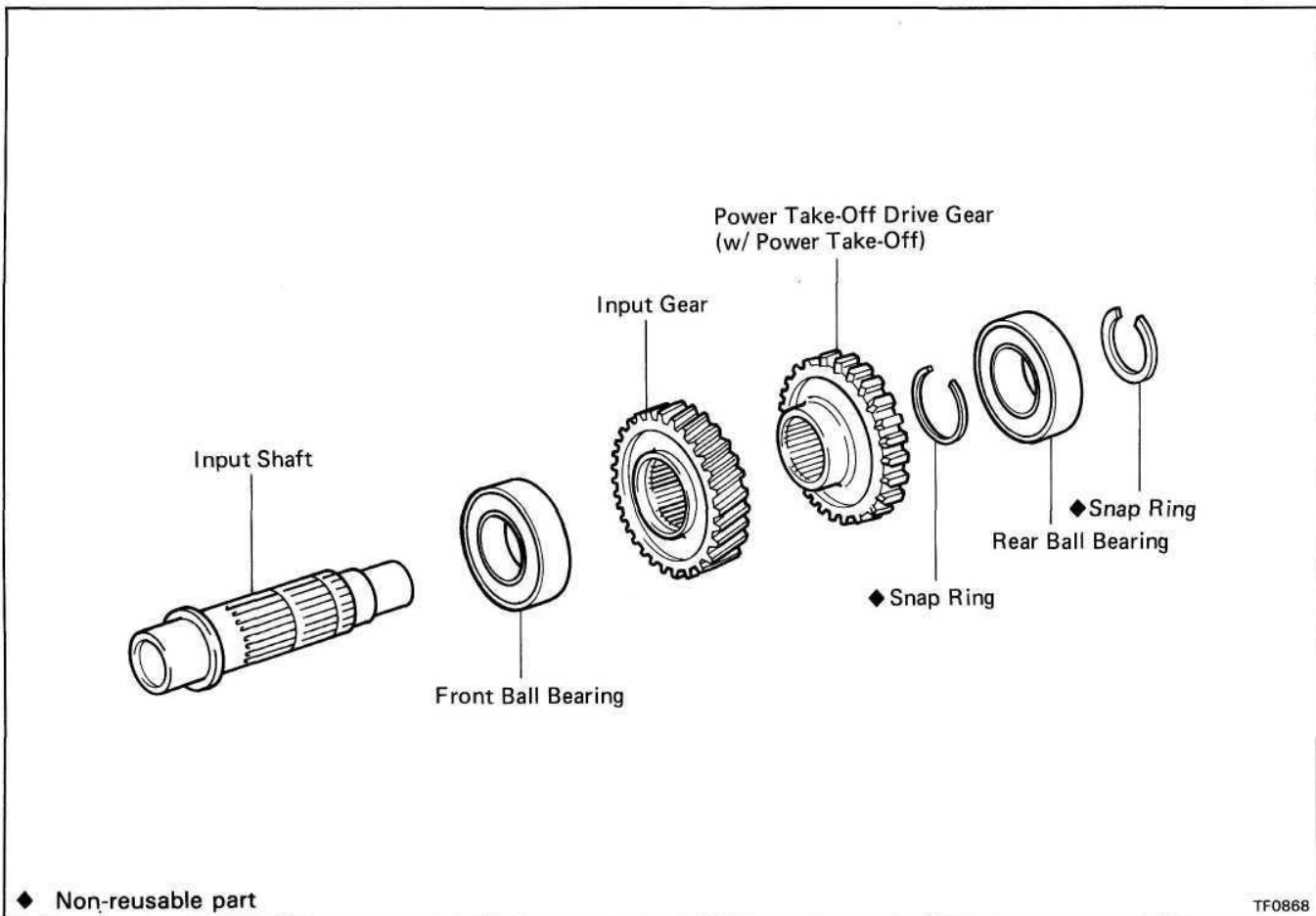

DISASSEMBLY OF INPUT SHAFT ASSEMBLY

1. REMOVE REAR BALL BEARING

- (a) Using snap ring pliers, remove the snap ring.

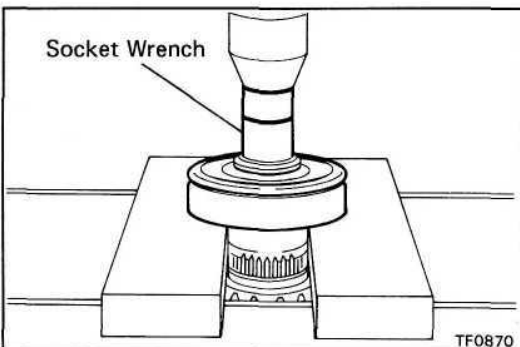

- (b) Using a press and socket wrench, remove the rear ball bearing.

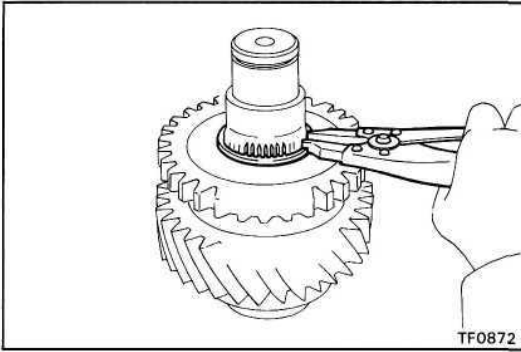

2. (w/ POWER TAKE-OFF)
REMOVE POWER TAKE-OFF DRIVE GEAR
(a) Using snap ring pliers, remove the snap ring.

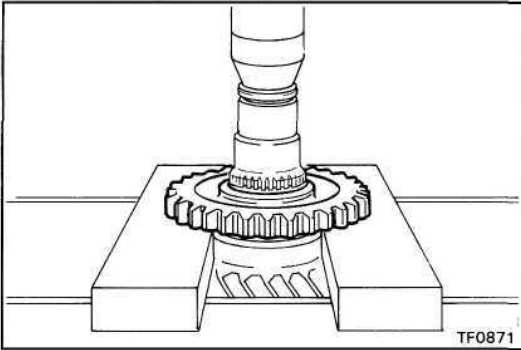

- (b) Using a press, remove the power take-off drive gear.

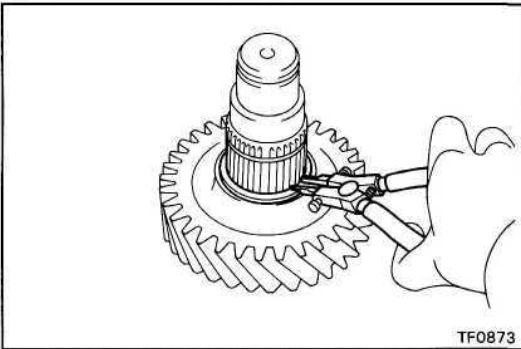

3. **REMOVE INPUT GEAR**
(a) (w/o Power take-off)
Using snap ring pliers, remove the snap ring.

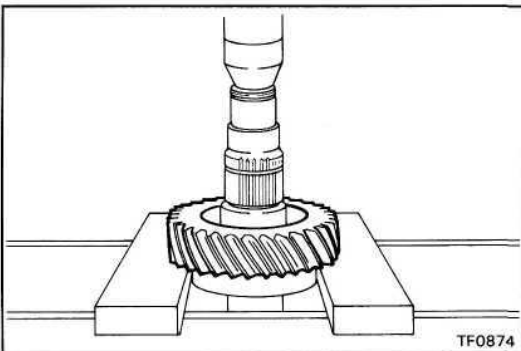

- (b) Using a press, remove the input gear.

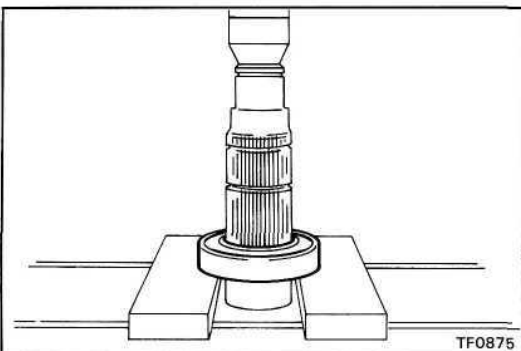

4. **REMOVE FRONT BALL BEARING**
Using a press, remove the front ball bearing.

ASSEMBLY OF INPUT SHAFT ASSEMBLY

1. INSTALL FRONT BALL BEARING

Using a press, install the front ball bearing.

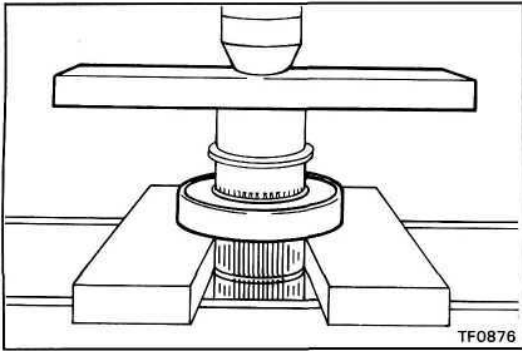

2. INSTALL INPUT GEAR

(a) Using a press, install the input gear.

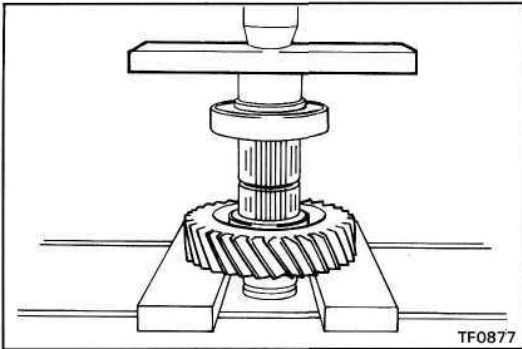

(b) (w/o Power take-off)

Select a snap ring that will allow minimum axial play and install it on the shaft.

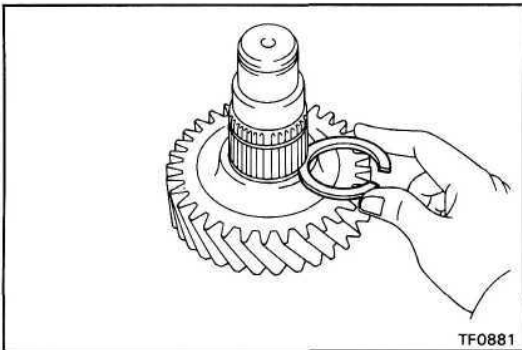

| Mark | Thickness mm (in.) |
|------|--------------------|
| A | 2.0 (0.0787) |
| B | 2.1 (0.0827) |
| C | 2.2 (0.0866) |
| D | 2.3 (0.0906) |
| E | 2.4 (0.0945) |
| F | 2.5 (0.0984) |
| G | 2.6 (0.1024) |
| H | 2.7 (0.1063) |
| J | 2.8 (0.1102) |

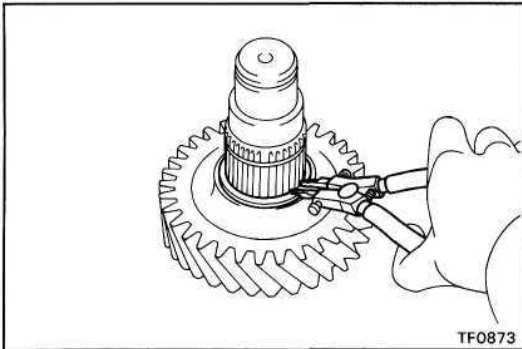

**3. (w/ POWER TAKE-OFF)
INSTALL POWER TAKE-OFF GEAR**

(a) Using a press, install the power take-off gear.

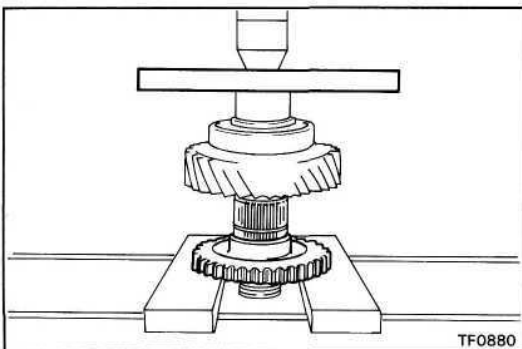

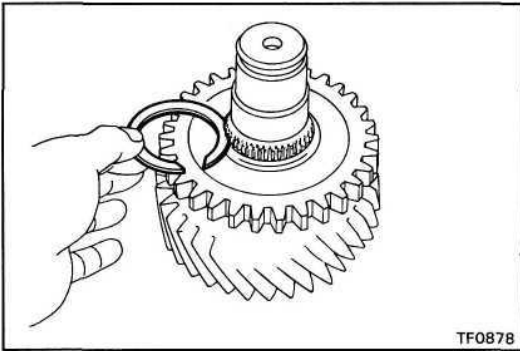

- (b) Select a snap ring that will allow minimum axial play and install it on the shaft.

| Mark | Thickness mm (in.) |
|------|--------------------|
| A | 2.0 (0.0787) |
| B | 2.1 (0.0827) |
| C | 2.2 (0.0866) |
| D | 2.3 (0.0906) |
| E | 2.4 (0.0945) |
| F | 2.5 (0.0984) |
| G | 2.6(0.1024) |
| H | 2.7(0.1063) |
| J | 2.8(0.1102) |

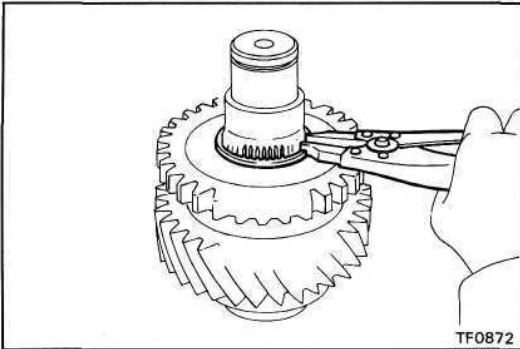

4. INSTALL REAR BALL BEARING

- (a) Using SST and a press, install the rear ball bearing.
SST 09316-60010 (09316-00030)

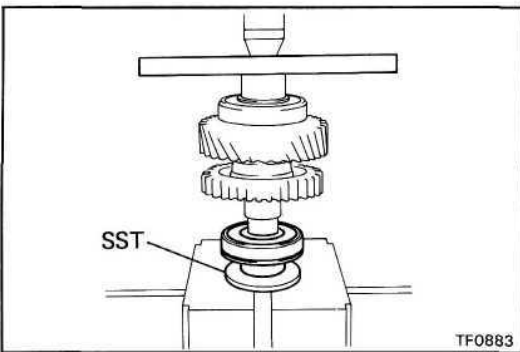

- (b) Select a snap ring that will allow minimum axial play.

| Mark | Thickness mm (in.) |
|------|--------------------|
| A | 2.0 (0.0787) |
| B | 2.1 (0.0827) |
| C | 2.2 (0.0866) |
| D | 2.3 (0.0906) |
| E | 2.4 (0.0945) |

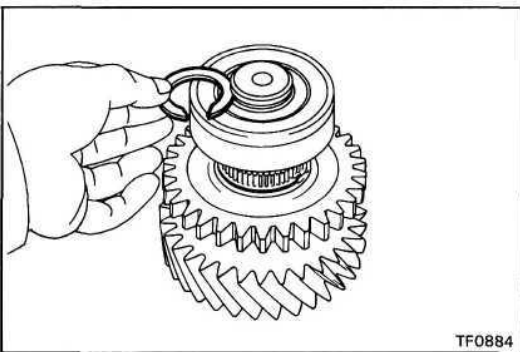

- (c) Using snap ring pliers, install the snap ring.

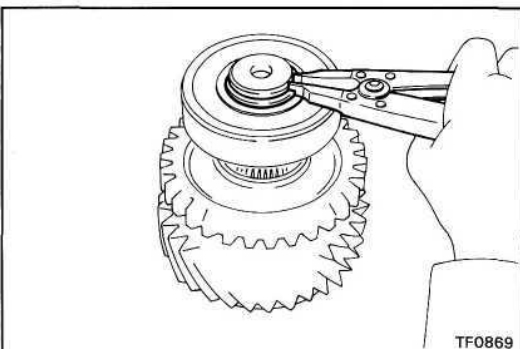

Idler Gear Assembly

COMPONENTS

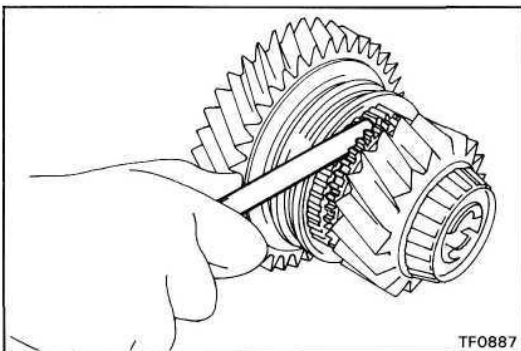
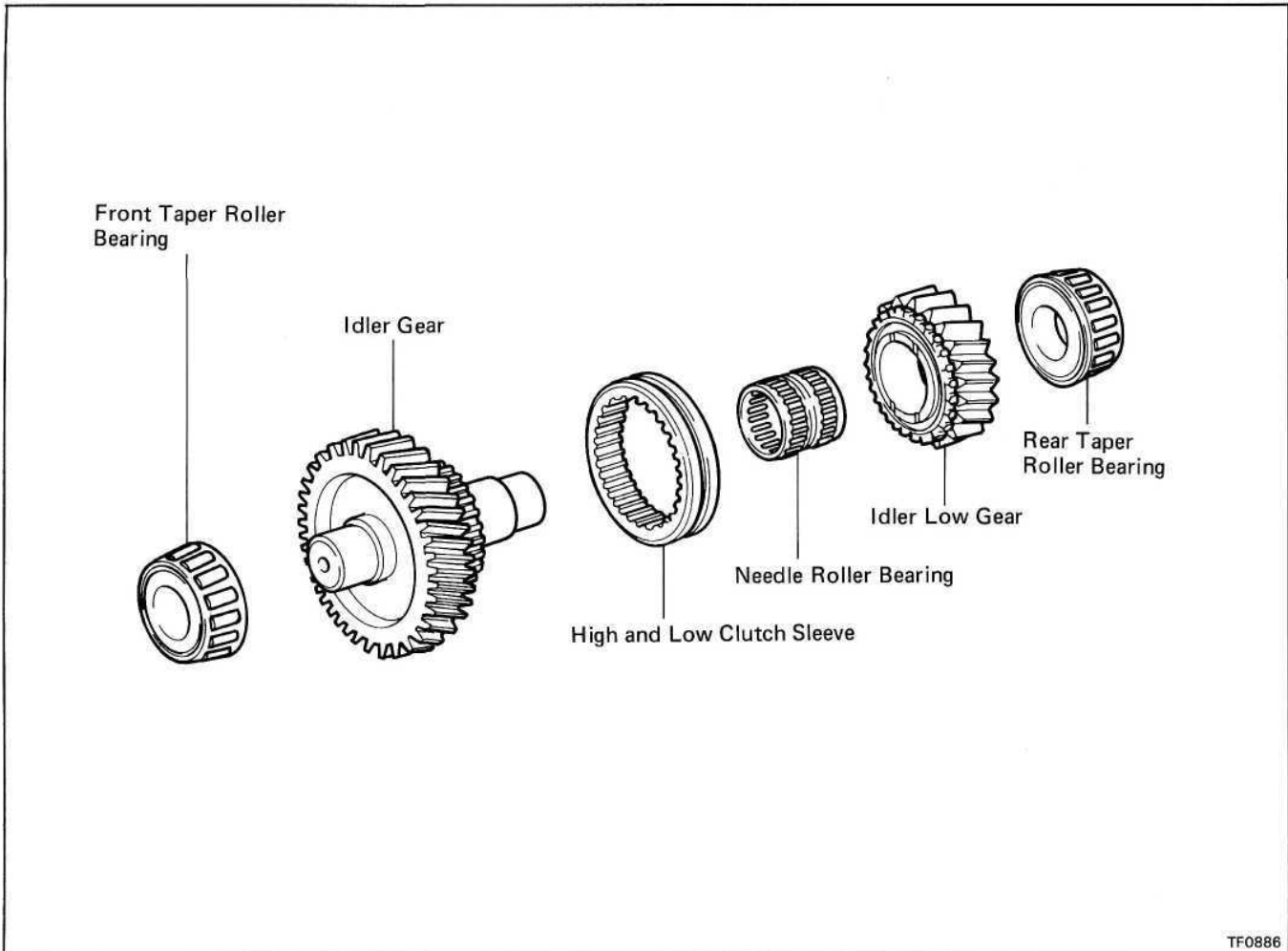

DISASSEMBLY OF IDLER GEAR ASSEMBLY

1. CHECK OIL CLEARANCE AND THRUST CLEARANCE OF IDLER LOW GEAR

- (a) Using a feeler gauge, measure the idler low gear thrust clearance.

Standard clearance: 0.125 — 0.275 mm
(0.0049 - 0.0108 in.)

Maximum clearance: 0.275 mm (0.0108 in.)

- (b) Using a dial indicator, measure the idler low gear oil clearance.

Standard clearance: 0.015 — 0.068 mm
(0.0006 - 0.0027 in.)

Maximum clearance: 0.068 mm (0.0027 in.)

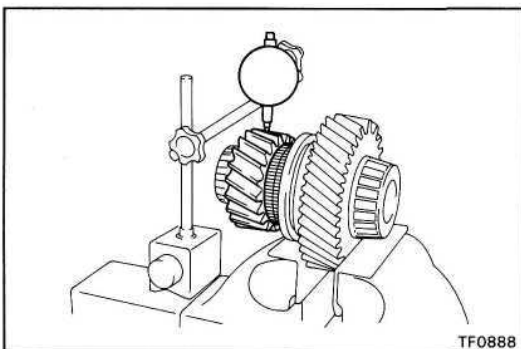

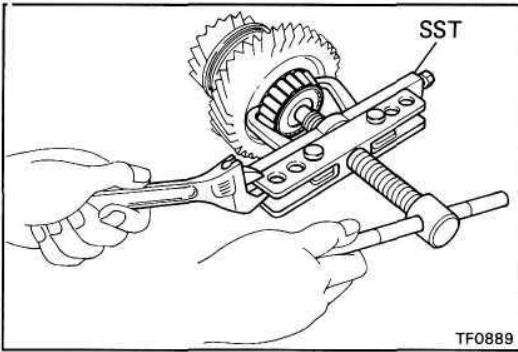
**2. REMOVE FRONT TAPER ROLLER BEARING**

Using SST, remove the front taper roller bearing.
SST 09950-20017

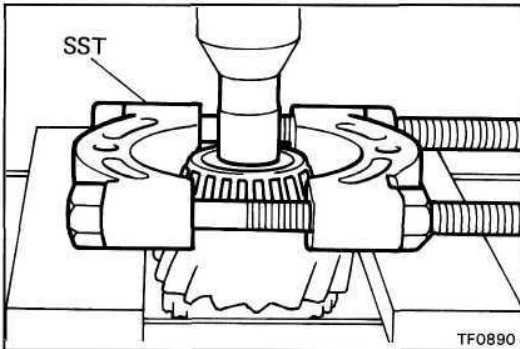
**3. REMOVE REAR TAPER ROLLER BEARING**

Using SST, press and socket wrench, remove the rear taper roller bearing.
SST 09950-00020

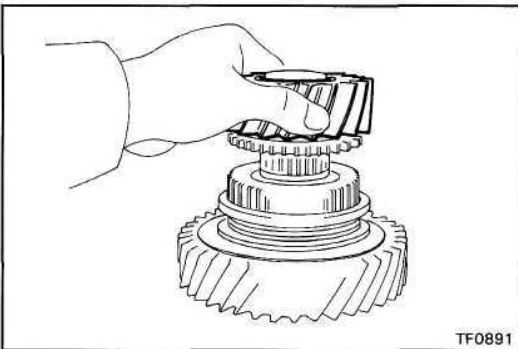
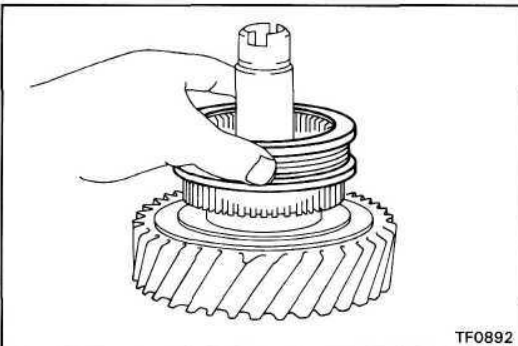
**4. REMOVE IDLER LOW GEAR AND NEEDLE ROLLER BEARING****5. REMOVE HIGH AND LOW CLUTCH SLEEVE**

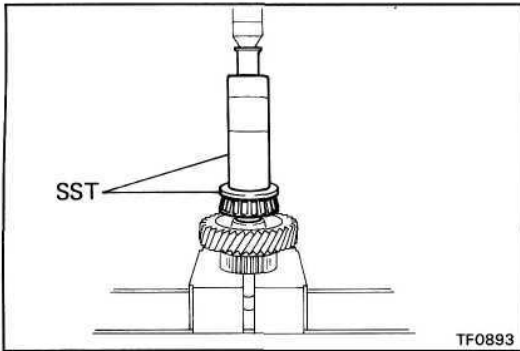

TF0893

ASSEMBLY OF IDLER GEAR ASSEMBLY

1. INSTALL FRONT TAPER ROLLER BEARING

Using SST and a press, install the front taper roller bearing.

SST 09316-60010 (09316-00010, 09316-00030)

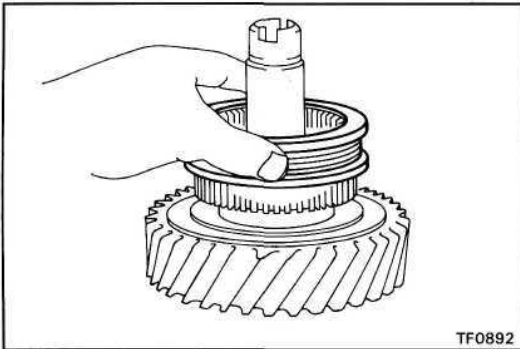

TF0892

2. INSTALL HIGH AND LOW CLUTCH SLEEVE

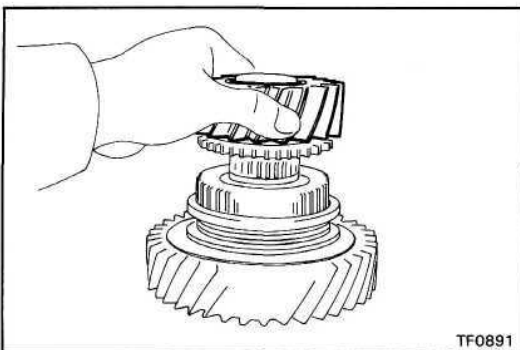

TF0891

3. INSTALL NEEDLE ROLLER BEARING AND IDLER LOW GEAR

(a) Apply gear oil to the needle roller bearing.

(b) Install the needle roller bearing and Idler low gear.

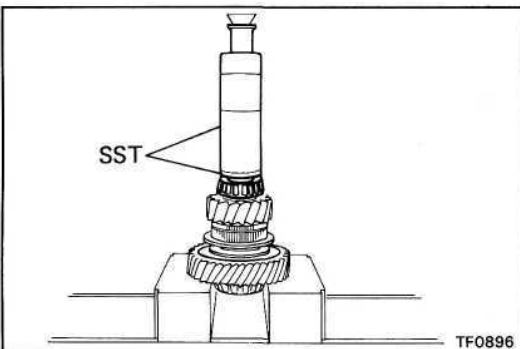

TF0896

4. INSTALL REAR TAPER ROLLER BEARING

Using SST and a press, install the rear taper roller bearing.

SST 09316-60010 (09316-00010, 09316-00070)

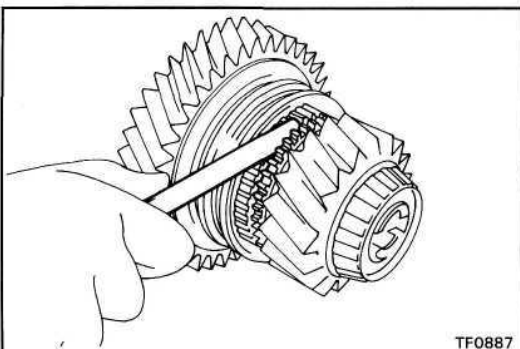

TF0887

5. MEASURE OIL CLEARANCE AND THRUST CLEARANCE OF IDLE LOW GEAR

(a) Using a feeler gauge, measure the idler low gear thrust clearance.

Standard clearance: 0.125 — 0.275 mm
(0.0049 - 0.0108 in.)

Maximum clearance: 0.275 mm (0.0108 in.)

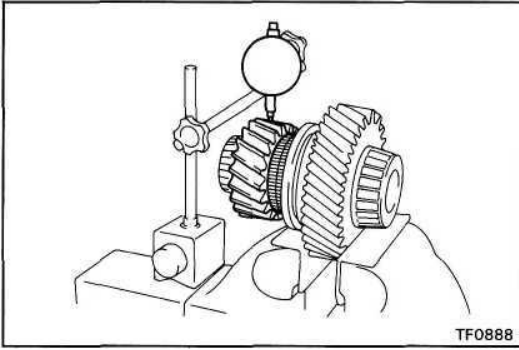

(b) Using a dial indicator, measure the idler low gear oil clearance.

Standard clearance: 0.015 — 0.068 mm
(0.0006 - 0.0027 in.)

Maximum clearance: 0.068 mm (0.0027 in.)

Center Differential Assembly COMPONENTS

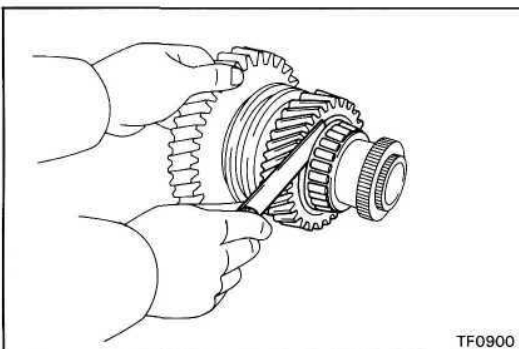
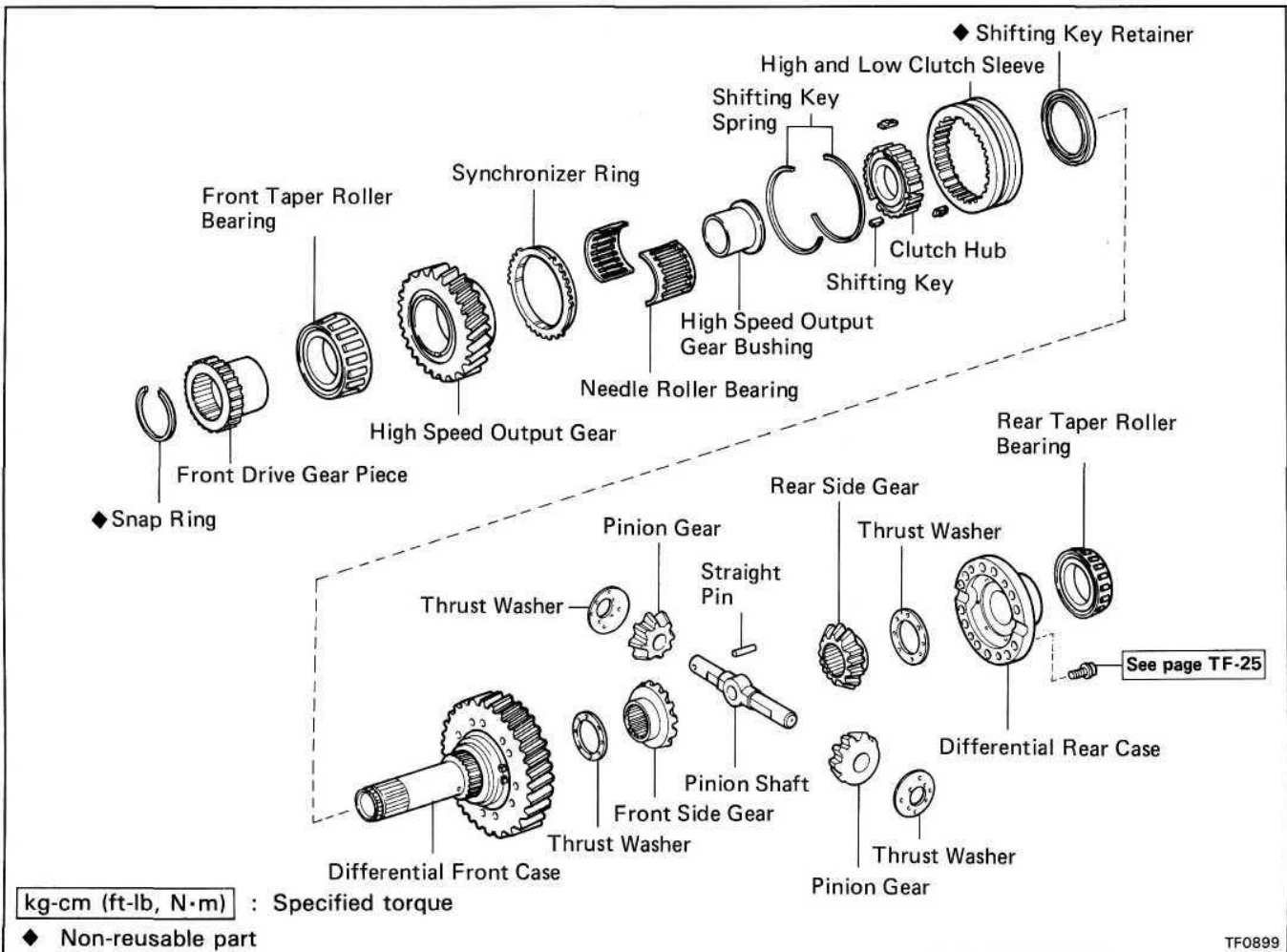

DISASSEMBLY OF CENTER DIFFERENTIAL ASSEMBLY

1. CHECK OIL CLEARANCE AND THRUST CLEARANCE OF HIGH SPEED OUTPUT GEAR

- (a) Using a feeler gauge, measure the high speed output gear thrust clearance.

Standard clearance: 0.10 — 0.25 mm
(0.0039 - 0.0098 in.)

Maximum clearance: 0.25 mm (0.0098 in.)

- (b) Using a dial indicator, measure the high speed output gear oil clearance.

Standard clearance: 0.015 — 0.071 mm
(0.0006 - 0.0028 in.)

Maximum clearance: 0.071 mm (0.0028 in.)

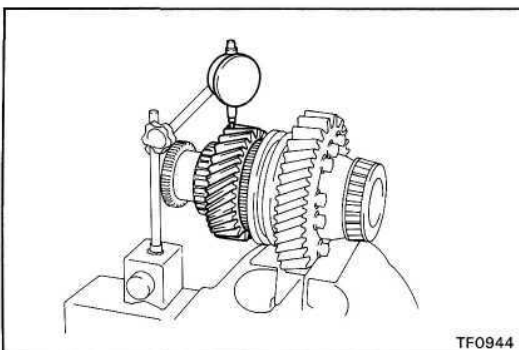

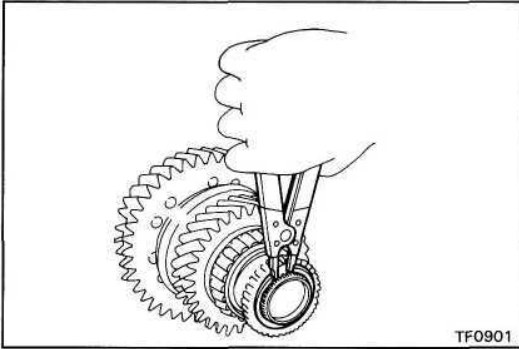
**2. REMOVE FRONT DRIVE GEAR PIECE**

- (a) Using snap ring pliers, remove the snap ring.

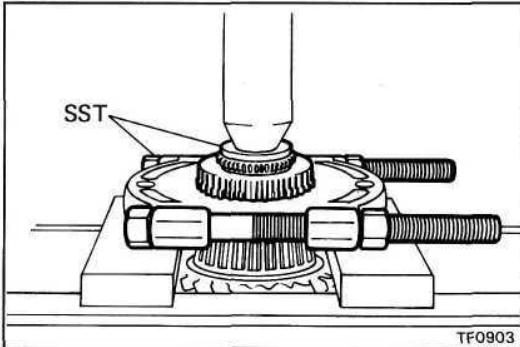

- (b) Using SST and a press, remove the front drive gear piece.

SST 09950-00020, 09950-20017 (09958-30010)

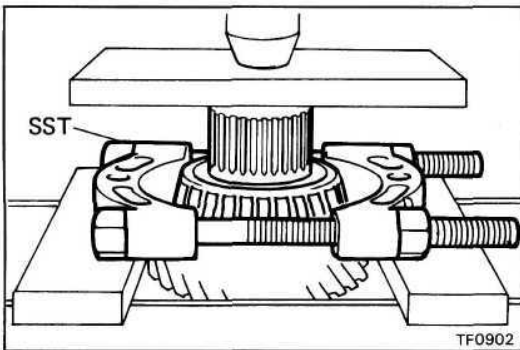
**3. REMOVE FRONT TAPER ROLLER BEARING**

- Using SST and a press, remove the front taper roller bearing.

SST 09950-00020

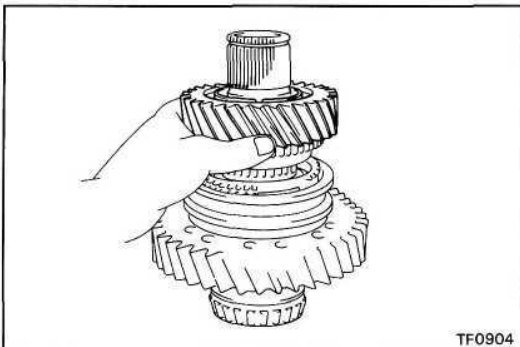
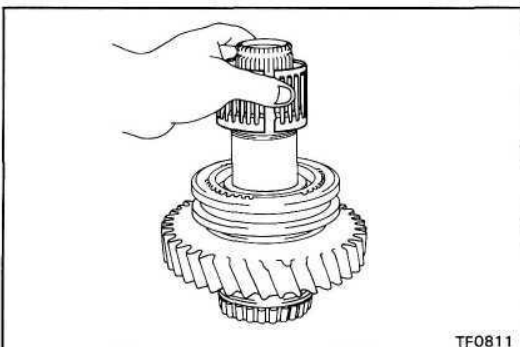
**4. REMOVE HIGH SPEED OUTPUT GEAR AND SYNCHRONIZER RING****5. REMOVE NEEDLE ROLLER BEARING**

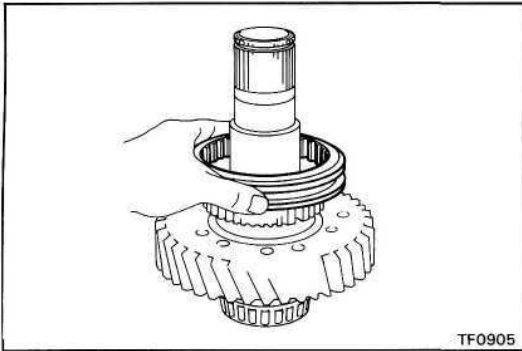

6. REMOVE HIGH AND LOW CLUTCH SLEEVE

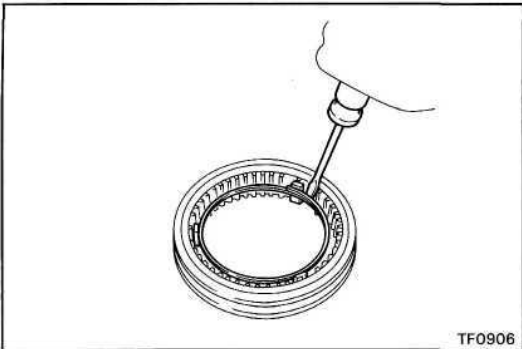

7. REMOVE HIGH AND LOW CLUTCH SLEEVE SHIFTING KEYS AND SPRINGS

Using a screwdriver, remove the two shifting key springs and shifting keys.

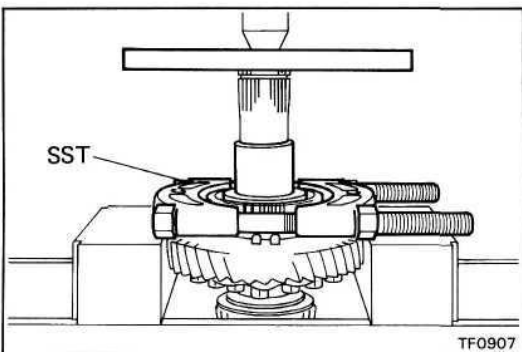

8. REMOVE HIGH SPEED OUTPUT GEAR BUSHING, CLUTCH HUB AND SHIFTING KEY RETAINER

(a) Using SST and a press, remove the high speed output gear bushing, clutch hub and shifting key retainer.

SST 09555-55010

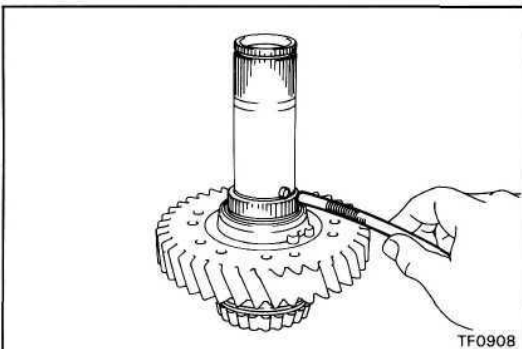

(b) Using a magnetic finger, remove the two straight pins.

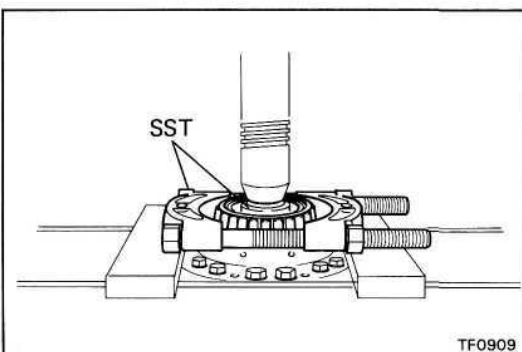

9. REMOVE REAR TAPER ROLLER BEARING

Using SST and a press, remove the rear taper roller bearing.

SST 09950-00020, 09950-20017 (09958-30010)

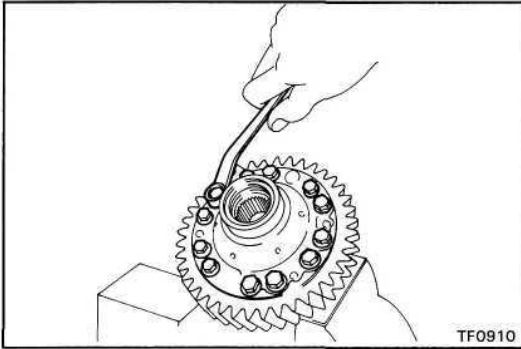
**10. REMOVE DIFFERENTIAL REAR CASE**

Remove the twelve bolts and differential rear case.

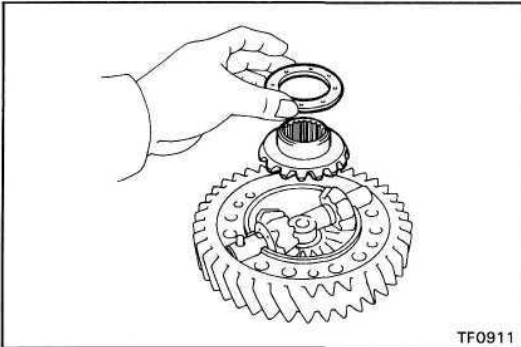
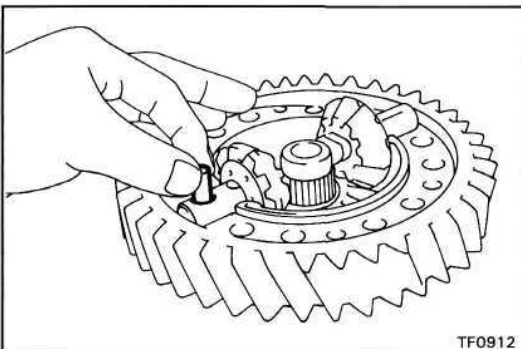
**11. REMOVE REAR SIDE GEAR AND THRUST WASHER****12. REMOVE PINION SHAFT, PINION GEAR AND THRUST WASHER**

(a) Remove the straight pin.

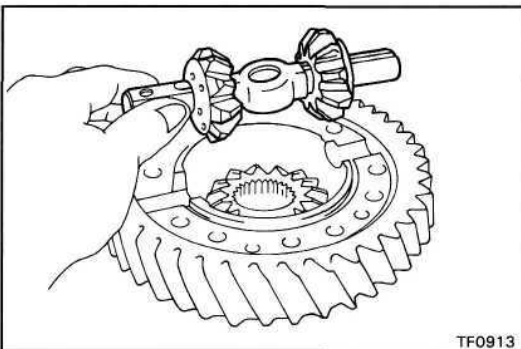

(b) Remove the pinion shaft, pinion gear and thrust washer.

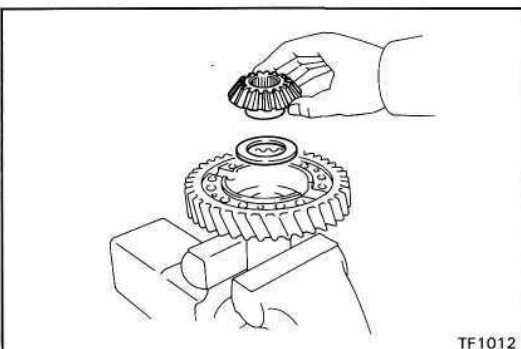

(c) Remove the front side gear and thrust washer.

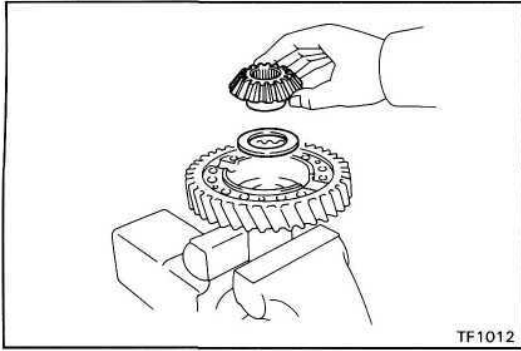

ASSEMBLY OF CENTER DIFFERENTIAL ASSEMBLY

1. INSTALL PINION SHAFT, PINION GEAR AND THRUST WASHER

HINT: Coat all of the sliding and rotating surface with gear oil before assembly.

(a) Install the front side gear and thrust washer to the differential front case.

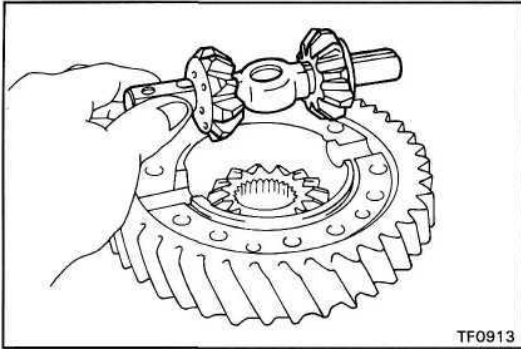

(b) Install the two pinion gears and thrust washers to the differential front case.

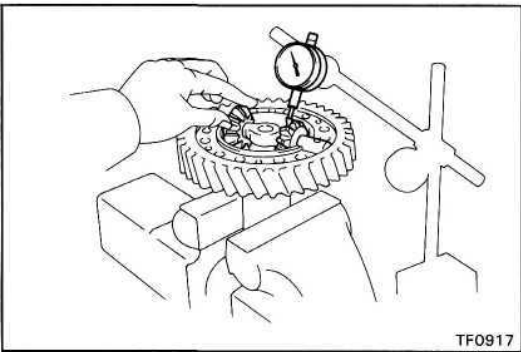

(c) Using a dial indicator, measure the front case backlash.

HINT: Push the pinion shaft.

Minimum backlash: 0.05 mm (0.0020 in.)

If the backlash is not within specification, replace the thrust washer with one of the correct size and reinstall the thrust washer.

| Thickness | mm (in.) |
|-----------|----------|
| 1.70 | (0.0669) |
| 1.85 | (0.0728) |
| 2.00 | (0.0787) |
| 2.15 | (0.0846) |
| 2.30 | (0.0906) |
| 2.45 | (0.0965) |
| 2.60 | (0.1024) |
| 2.75 | (0.1083) |
| 2.90 | (0.1142) |
| 3.05 | (0.1201) |

(d) Measure the rear case backlash.

(See steps (a) to (c))

2. INSTALL STRAIGHT PIN

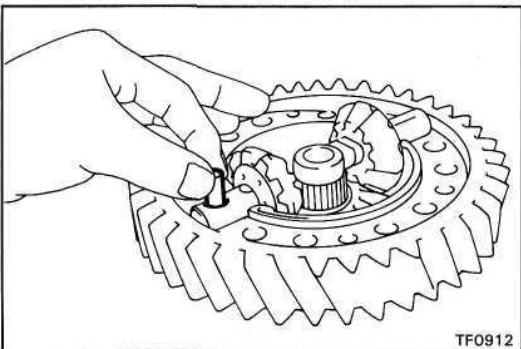

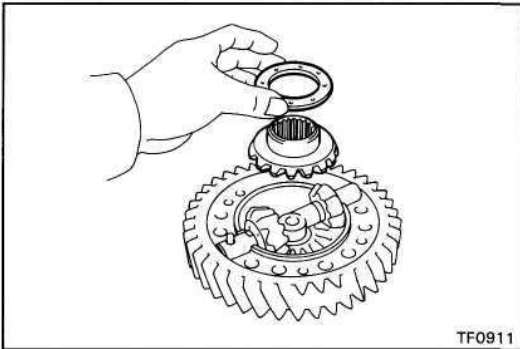
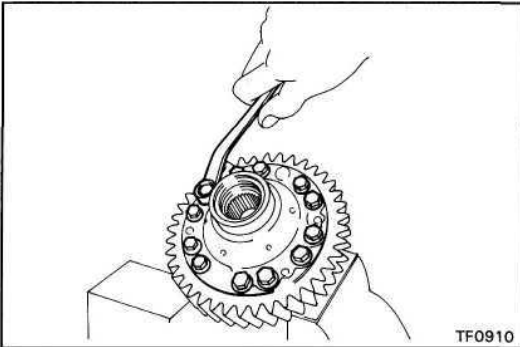
**3. INSTALL REAR SIDE GEAR AND THRUST WASHER****4. INSTALL DIFFERENTIAL REAR CASE**

Temporary install the differential rear case and set bolts.

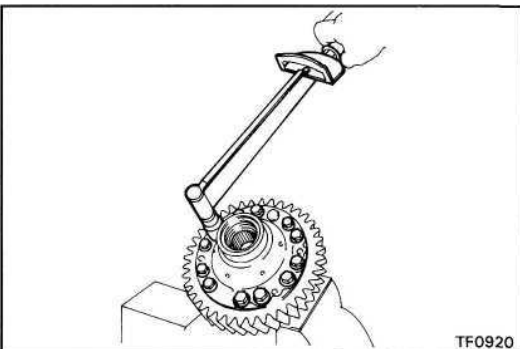
**5. TORQUE REAR CASE SET BOLTS**

(a) Torque the rear case set bolts.

Torque: 900 kg-cm (65 ft-lb, 88 Nm)

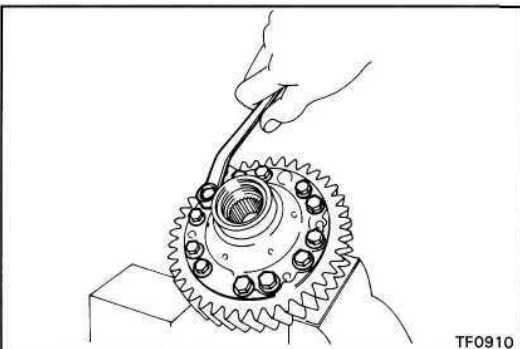

(b) Loosen the rear case set bolts.

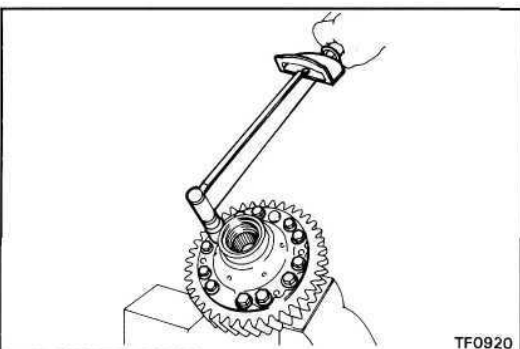

(c) Retorque the rear case set bolts.

Torque: 1,000 kg-cm (72 ft-lb, 98 Nm)

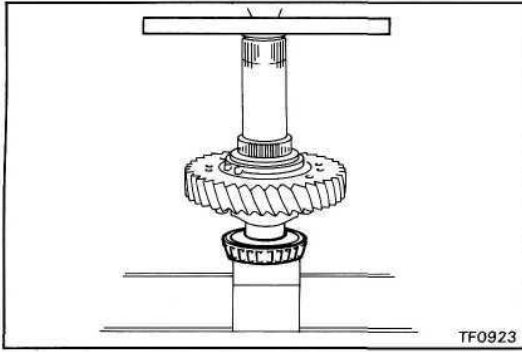

6. INSTALL REAR TAPER ROLLER BEARING

Using a press, install the rear taper roller bearing.

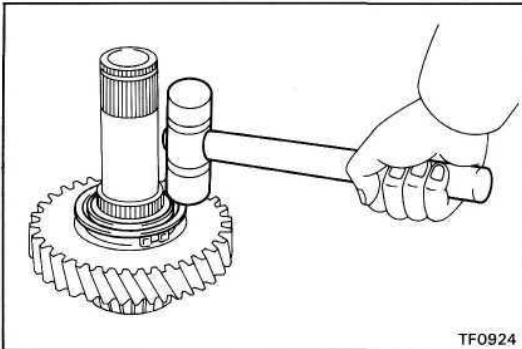

7. INSTALL SHIFTING KEY RETAINER

Using a plastic hammer, tap in the shifting key retainer.

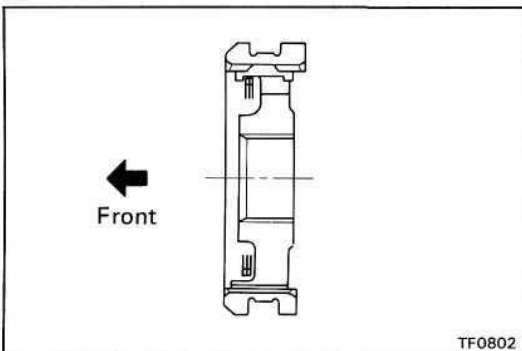

8. INSERT CLUTCH HUB INTO HIGH AND LOW CLUTCH SLEEVE

- (a) Install the clutch hub and shifting keys to the high and low clutch sleeve.
- (b) Install the shifting key springs.

NOTICE: Install the key springs positioned so that their end gaps are not in line.

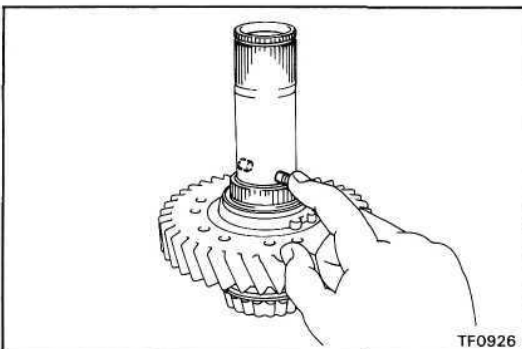

9. INSTALL HIGH AND LOW CLUTCH SLEEVE ASSEMBLY AND HIGH SPEED OUTPUT GEAR BUSHING

- (a) Apply MP grease to the straight pin.
- (b) Install the two straight pins.

- (c) Using SST and a press, install the clutch sleeve assembly and high speed output gear bushing.

SST 09316-60010 (09316-00010)

NOTICE: Before pressing, align the holes on the bushing and shaft so that the pin on the shaft aligned with the cutting portion of the bushing.

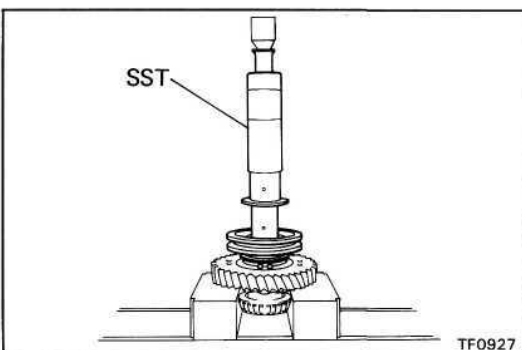

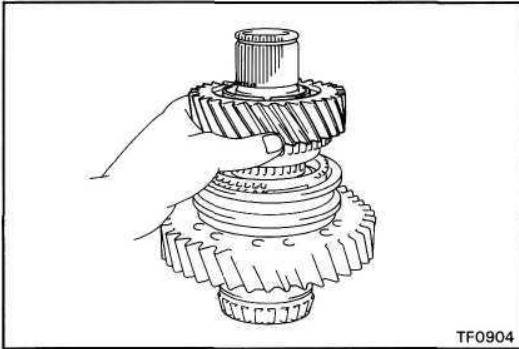

10. INSTALL HIGH SPEED OUTPUT GEAR AND NEEDLE ROLLER BEARING

- (a) Apply gear oil to the needle roller bearing.
- (b) Place the synchronizer ring on the gear and install the high speed output gear and needle roller bearing.

NOTICE: Align the ring slots with the shifting keys.

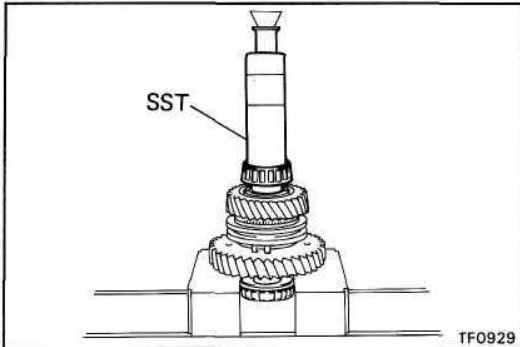

11. INSTALL FRONT TAPER ROLLER BEARING

Using SST and a press, install the front taper roller bearing.

SST 09316-60010 (09316-00010)

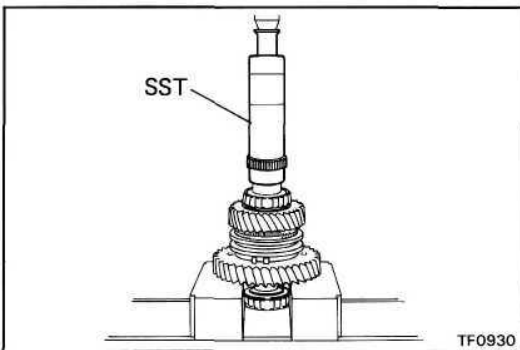

12. INSTALL FRONT DRIVE GEAR PIECE

Using SST and a press, install the front drive gear piece.

SST 09316-60010 (09316-00010)

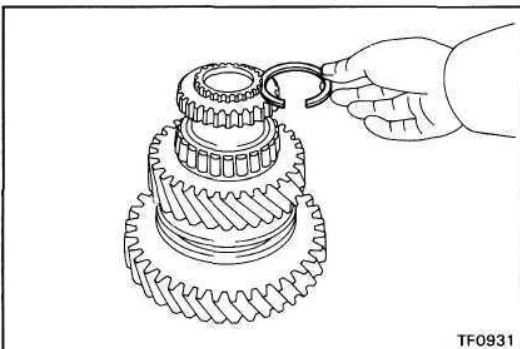

13. INSTALL SNAP RING

Select a snap ring that will allow minimum axial play and install it on the shaft.

| Mark | Thickness mm (in.) |
|------|--------------------|
| A | 2.00 (0.0787) |
| B | 2.10 (0.0827) |
| C | 2.20 (0.0866) |
| D | 2.30 (0.0906) |
| E | 2.40 (0.0945) |
| F | 2.50 (0.0984) |
| G | 2.60 (0.1024) |
| H | 2.70 (0.1063) |
| J | 2.80 (0.1102) |
| K | 1.80 (0.0709) |
| L | 1.90 (0.0748) |

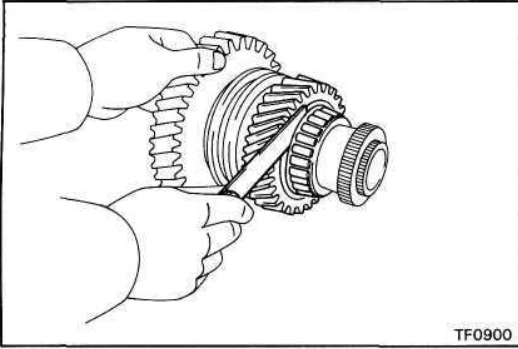
**14. MEASURE OIL CLEARANCE AND THRUST CLEARANCE OF HIGH SPEED OUTPUT GEAR THRUST CLEARANCE**

- (a) Using a feeler gauge, measure the high speed gear thrust clearance.

Standard clearance: 0.10 — 0.25 mm
(0.0039 - 0.0098 in.)

Maximum clearance: 0.25 mm (0.0098 in.)

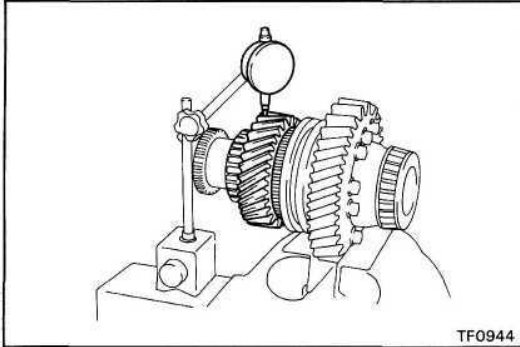

- (b) Using a dial indicator, measure the high speed gear oil clearance.

Standard clearance: 0.015 — 0.071 mm
(0.0006 - 0.0028 in.)

Maximum clearance: 0.071 mm (0.0028 in.)

Front Extension Housing Assembly COMPONENTS

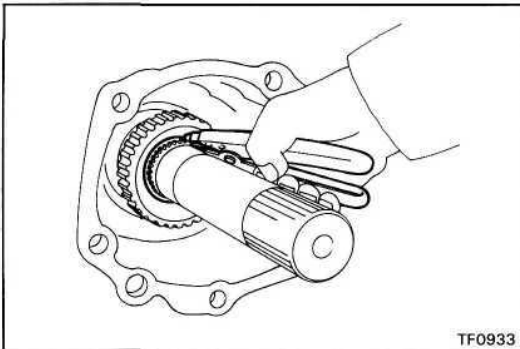
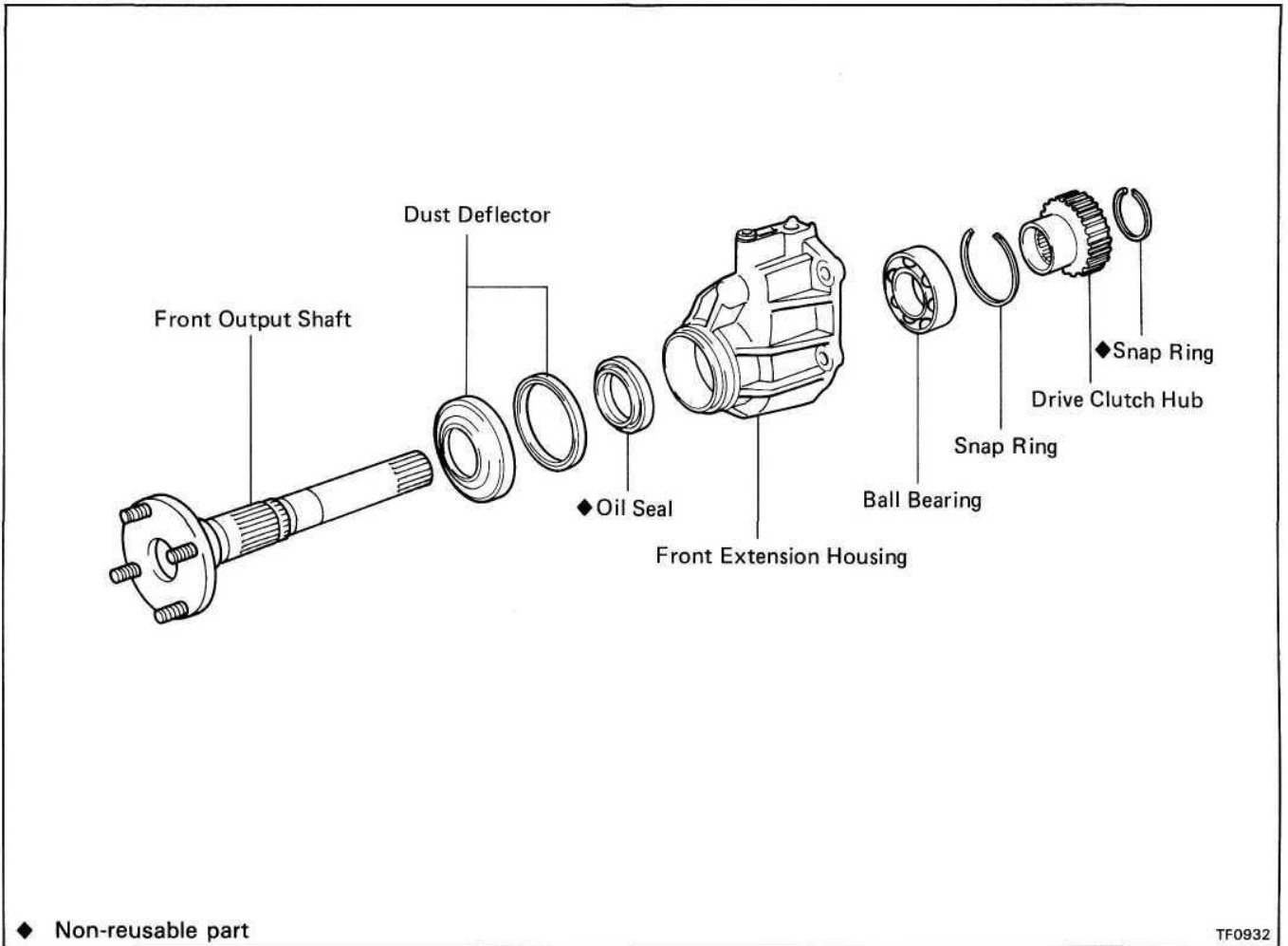

DISASSEMBLY OF FRONT EXTENSION HOUSING ASSEMBLY

1. REMOVE DRIVE CLUTCH HUB

(a) Using snap ring pliers, remove the snap ring.

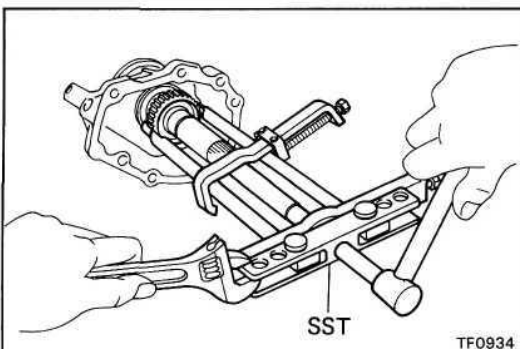

(b) Using SST, remove the drive clutch hub.
SST 09950-20017

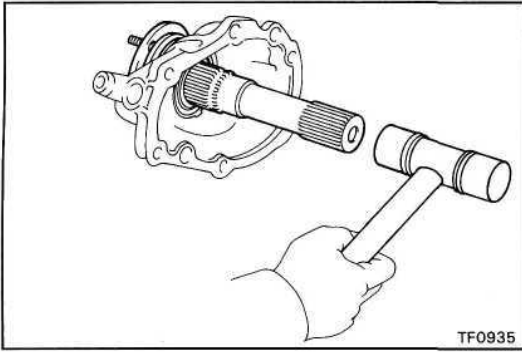
**2. REMOVE FRONT OUTPUT SHAFT**

Using a plastic hammer, tap the front output shaft and remove it.

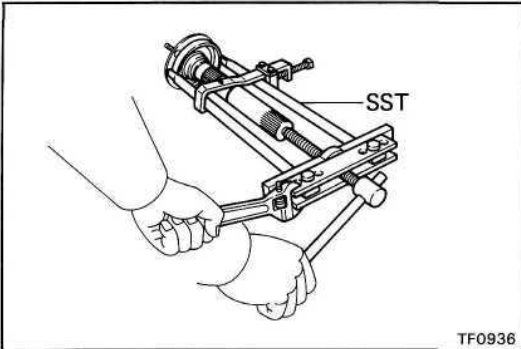
**3. REMOVE DUST DEFLECTORS**

(a) Using SST, remove the dust deflector.

SST 09950-20017

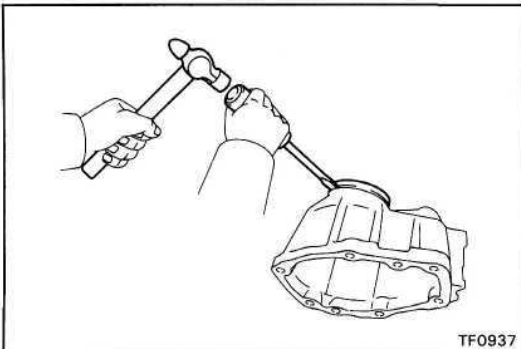

(b) Using a screwdriver and hammer, tap the dust deflector and remove it.

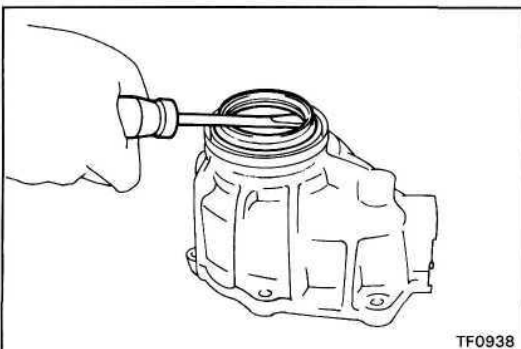
**4. REMOVE OIL SEAL**

Using a screwdriver, pry out the oil seal.

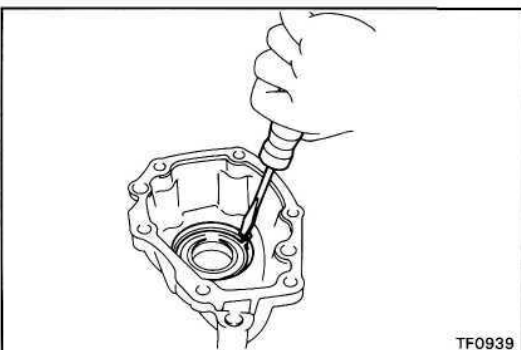
**5. REMOVE BALL BEARING**

(a) Using a screwdriver, remove the snap ring.

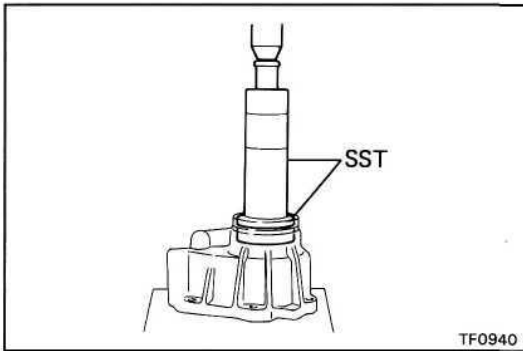

- (b) Using SST and a press, remove the ball bearing.
SST 09316-60010 (09316-00010, 09316-00070)

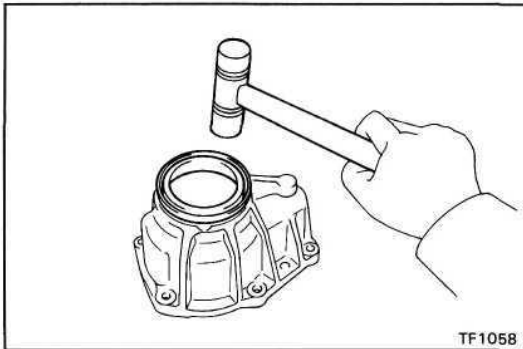

ASSEMBLY OF FRONT EXTENSION HOUSING ASSEMBLY

1. INSTALL DUST DEFLECTORS

- (a) Using a plastic hammer, install the dust deflector.

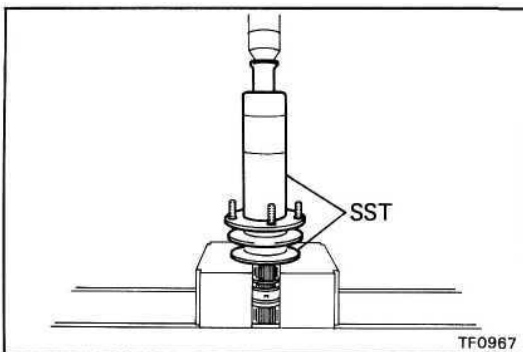

- (b) Using SST and a press, install the dust deflector.
SST 09316-20011, 09316-60010 (09316-00010)

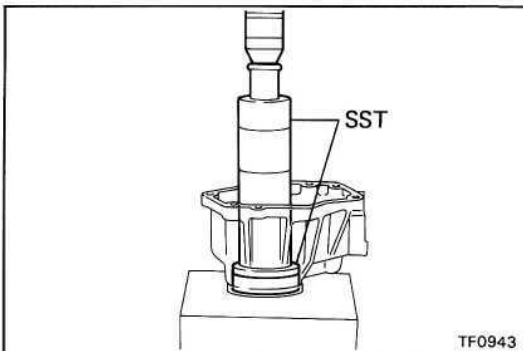

2. INSTALL BALL BEARING

- (a) Using SST and a press, install the ball bearing.
SST 09316-60010 (09316-00010, 09316-00030)

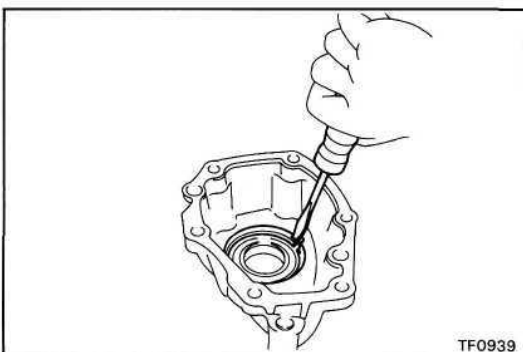

- (b) Using a screwdriver, install the snap ring.

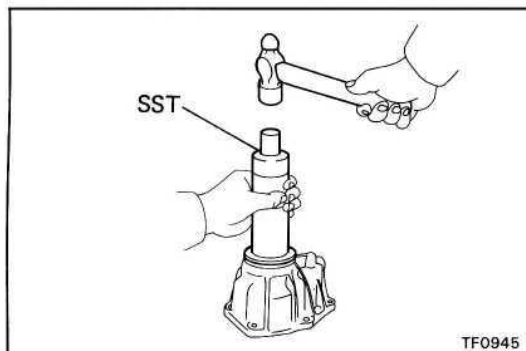
**3. INSTALL OIL SEAL**

Using SST and a hammer, drive in a new oil seal.

SST 09316-60010 (09316-00010, 09316-00060)

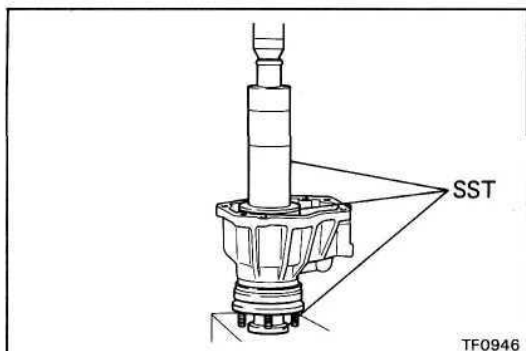
**4. INSTALL FRONT OUTPUT SHAFT AND DRIVE CLUTCH HUB**

(a) Using SST and press, install the front output shaft and drive clutch hub.

SST 09316-20011, 09316-60010 (09316-00010, 09316-00040, 09316-00070)

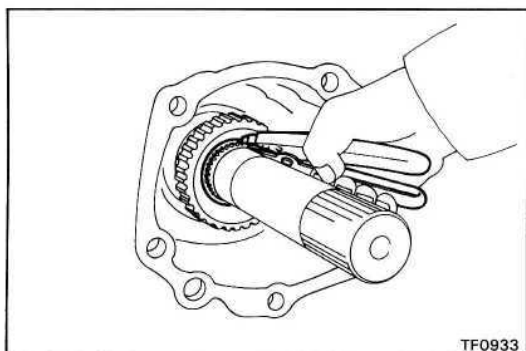

(b) Using snap ring pliers, install the snap ring.

Rear Extension Housing Assembly COMPONENTS

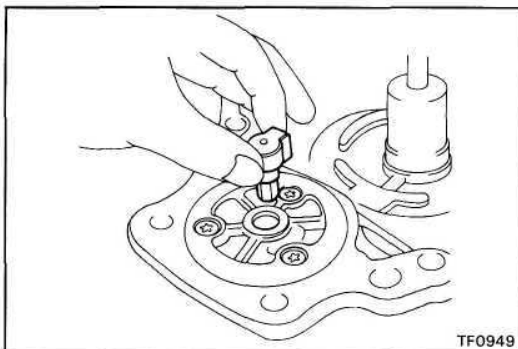
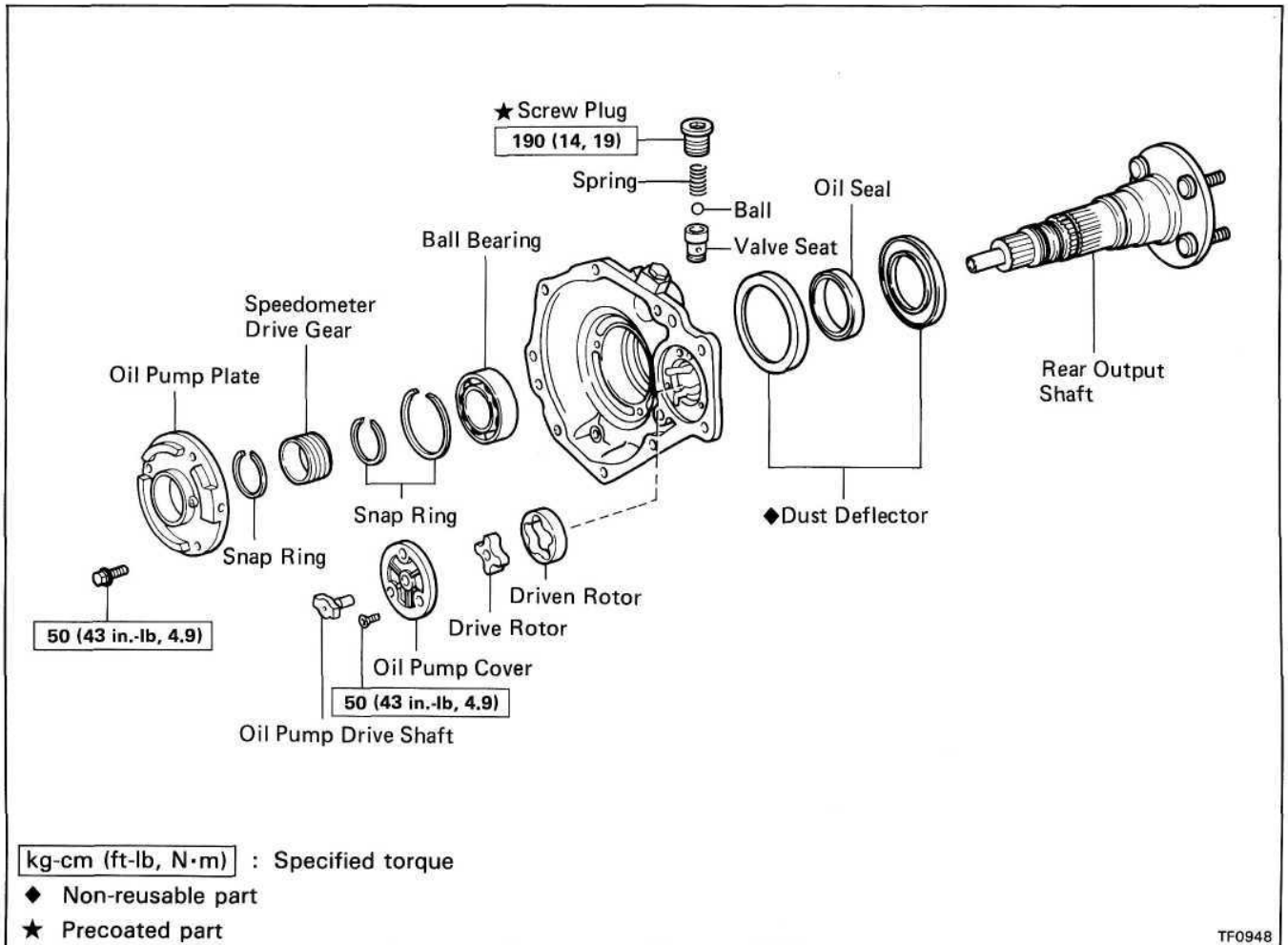

DISASSEMBLY OF REAR EXTENSION HOUSING ASSEMBLY

1. REMOVE OIL PUMP DRIVE SHAFT

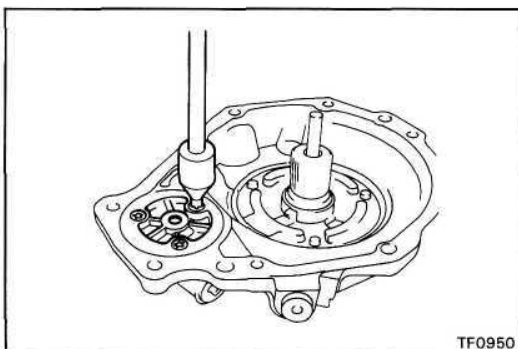

2. REMOVE OIL PUMP COVER

Using a torx socket wrench, remove the three screws and the oil pump cover.

(Torx socket wrench T30 09042-00010)

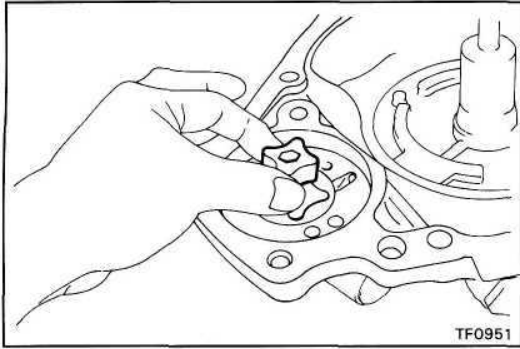
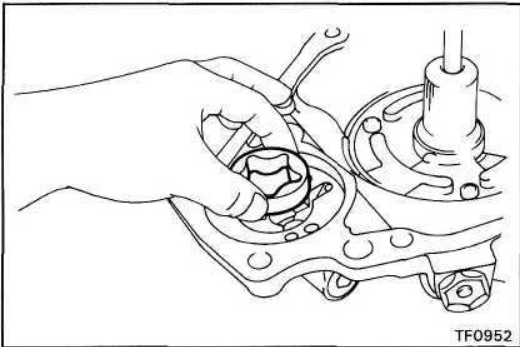
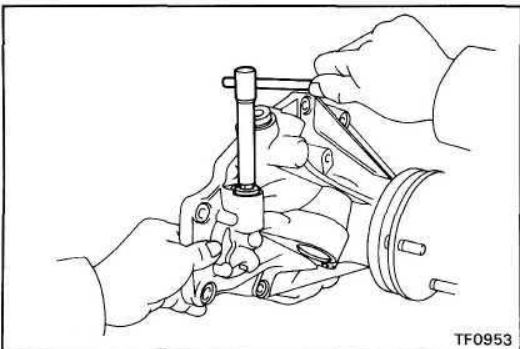
**3. REMOVE DRIVE ROTOR****4. REMOVE DRIVEN ROTOR****5. REMOVE SCREW PLUG, SPRING, BALL AND VALVE SEAT**

(a) Using a hexagon wrench, remove the screw plug.

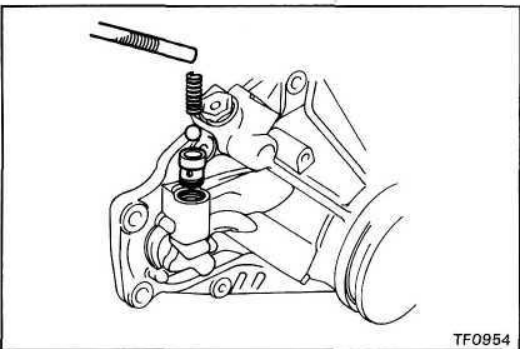

(b) Using a magnetic finger, remove the spring, ball and valve seat.

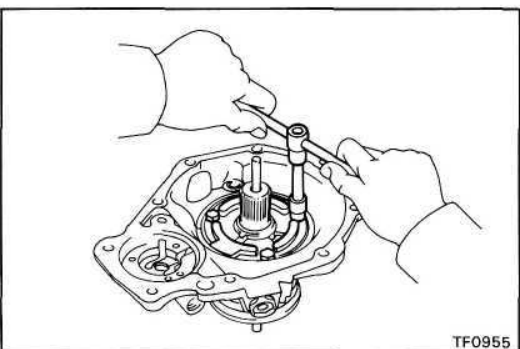
**6. REMOVE OIL PUMP PLATE**

Remove the three bolts and the oil pump plate.

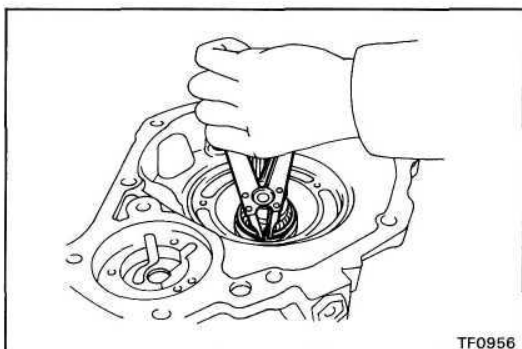
**7. REMOVE SPEEDOMETER DRIVE GEAR**

(a) Using snap ring pliers, remove the snap ring.

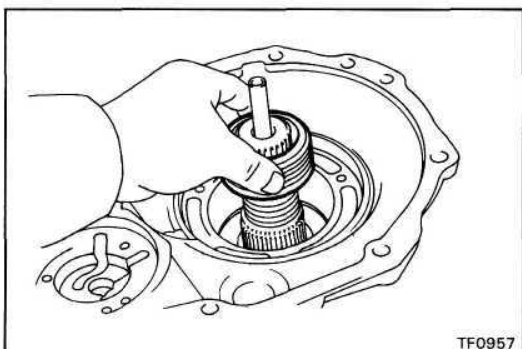

(b) Remove the speedometer drive gear.

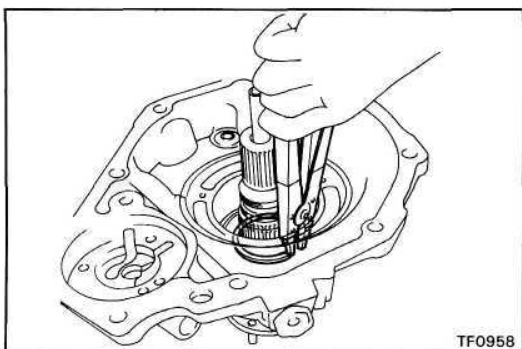
**8. REMOVE REAR OUTPUT SHAFT**

(a) Using snap ring pliers, remove the snap ring.

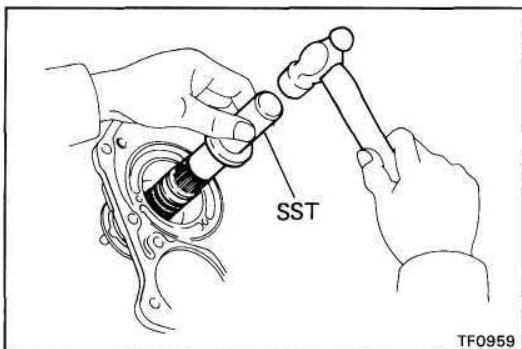

(b) Using SST and a hammer, remove the rear output shaft.

SST 09325-12010

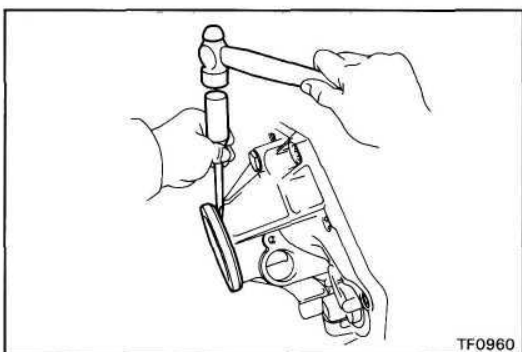
**9. REMOVE DUST DEFLECTORS**

(a) Using a screwdriver and hammer, remove the rear extension housing dust deflector.

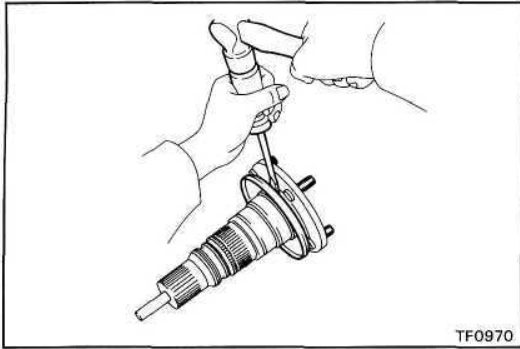

- (b) Using a screwdriver and hammer, remove the rear output shaft dust deflector.

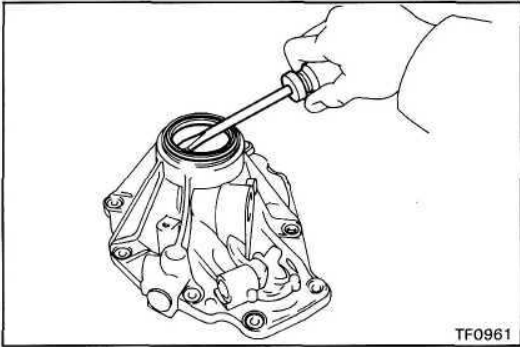

10. REMOVE OIL SEAL

Using a screwdriver, pry out the oil seal.

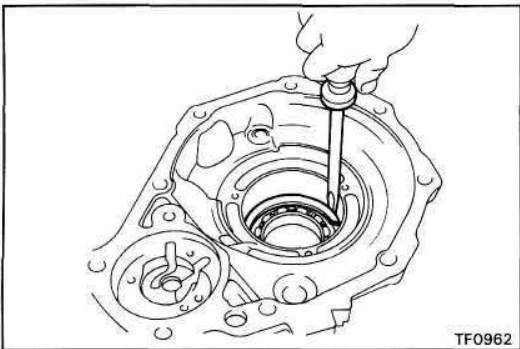

11. REMOVE BALL BEARING

- (a) Using a screwdriver, remove the snap ring.

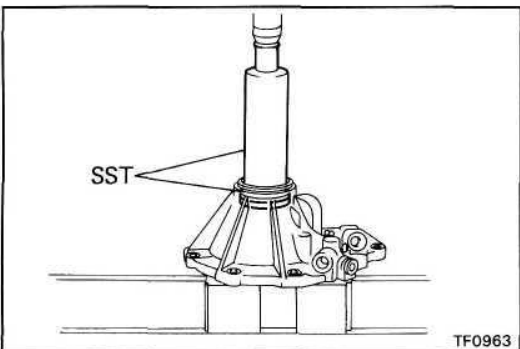

- (b) Using SST and a press, remove the ball bearing.
SST 09316-60010 (09316-00010, 09316-00020)

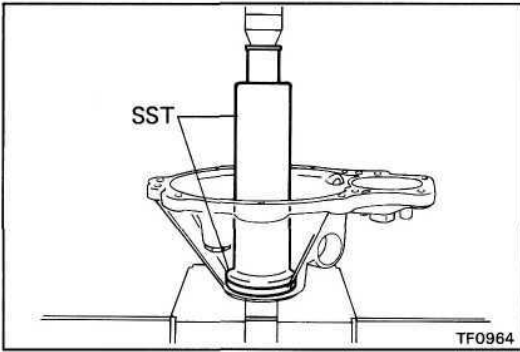

ASSEMBLY OF REAR EXTENSION HOUSING

1. INSTALL BALL BEARING

- (a) Using SST and a press, install the ball bearing.
SST 09316-60010 (09316-00010, 09316-00030)

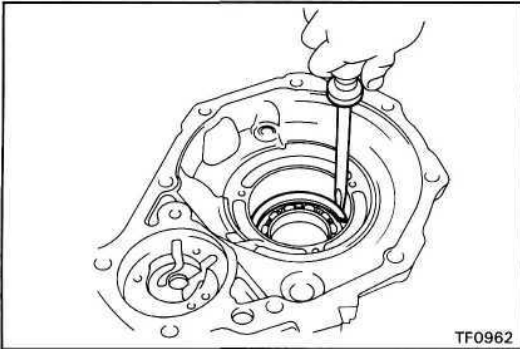

- (b) Using a screwdriver, install the snap ring.

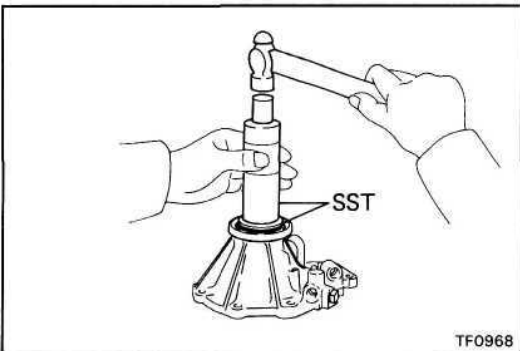

2. INSTALL DUST DEFLECTORS

- (a) Using SST and a hammer, install the rear extension housing dust deflector.

SST 09316-60010 (09316-00010, 09316-00040)

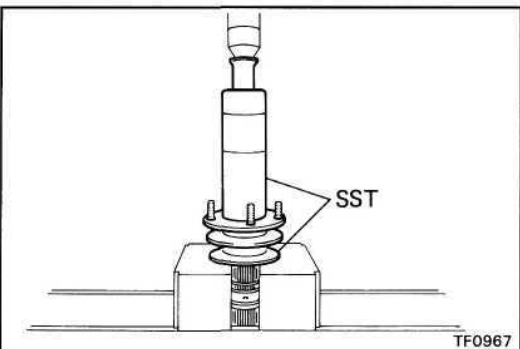

- (b) Using SST and a press, install the rear output shaft dust deflector.

SST 09316-20011, 09316-60010 (09316-00010)

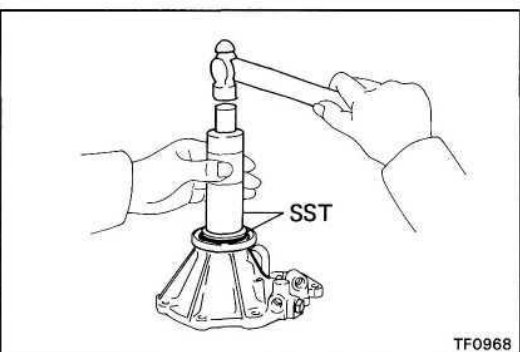

3. INSTALL OIL SEAL

- Using SST and a hammer, drive in a new oil seal.
SST 09316-60010 (09316-00010, 09316-00030)

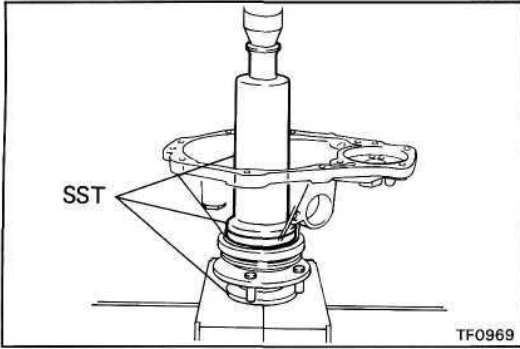

4. INSTALL REAR OUTPUT SHAFT

- (a) Using SST and a press, install the rear output shaft.
 SST 09316-20011, 09316-60010
 (09316-00010, 09316-00030)

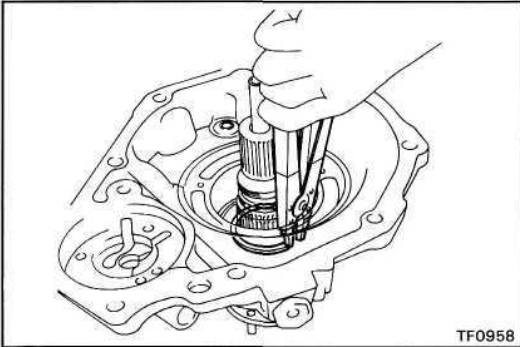

- (b) Using snap ring pliers, install the snap ring.

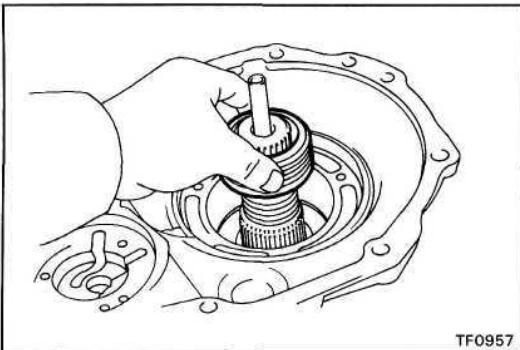

5. INSTALL SPEEDOMETER DRIVE GEAR

- (a) Install the speedometer drive gear.

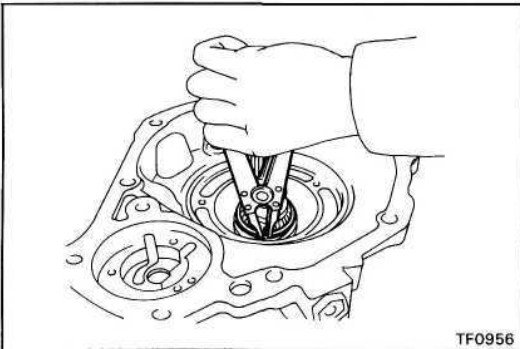

- (b) Using snap ring pliers, install the snap ring.

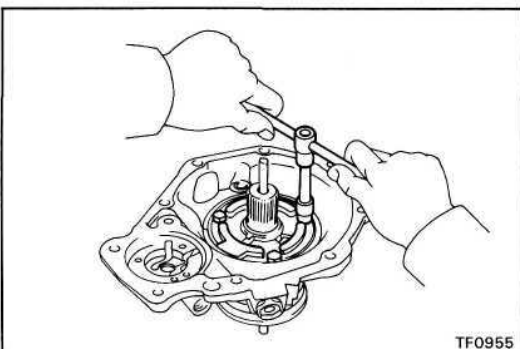

6. INSTALL OIL PUMP PLATE

- (a) Install the oil pump plate.
 (b) Install and torque the three bolts.
 Torque: 50 kg-cm (43 in.-lb, 4.9 N-m)

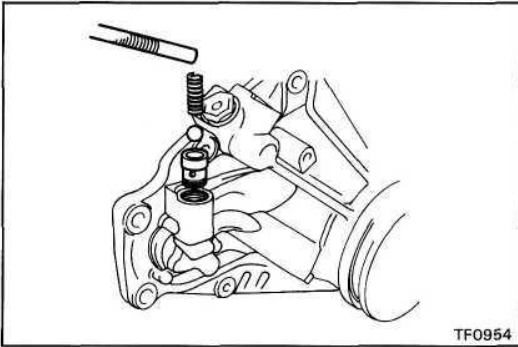

7. INSTALL VALVE SEAT, BALL, SPRING AND SCREW PLUG

- (a) Apply gear oil to the ball.
- (b) Install the valve seat, ball and spring.

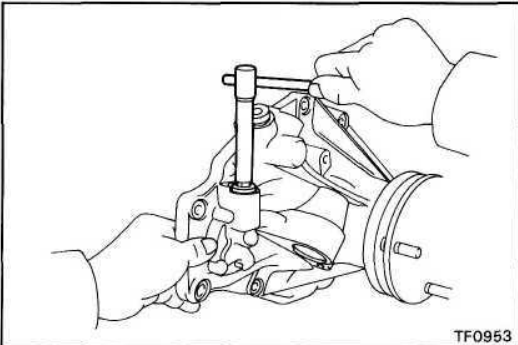

- (c) Apply liquid sealer to the screw plug.

Sealant: Part No.08833-00080, THREE BOND 1344, LOCTITE 242 or equivalent

- (d) Install and torque the screw plug.

Torque: 190 kg-cm (14 ft-lb, 19 N-m)

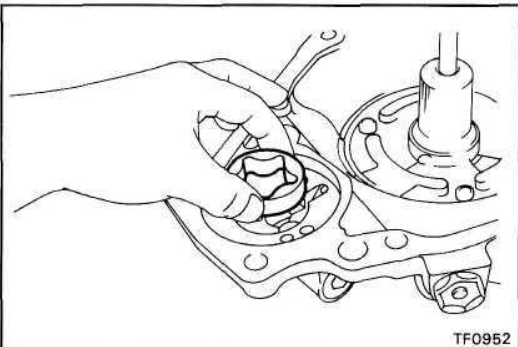

8. INSTALL DRIVEN ROTOR

- (a) Apply gear oil to the driven rotor.
- (b) Install the driven rotor.

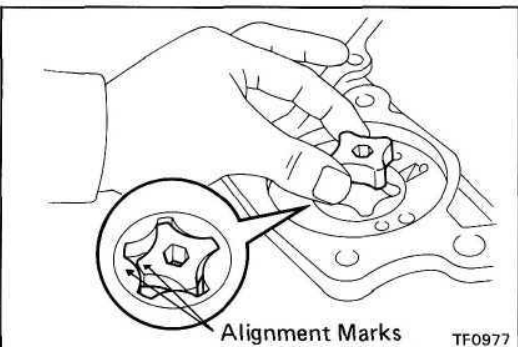

9. INSTALL DRIVE ROTOR

- (a) Apply gear oil to the drive rotor.
- (b) Install the drive rotor.

HINT: Align the alignment marks.

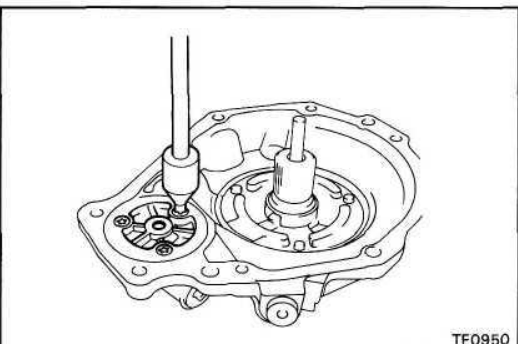

10. INSTALL OIL PUMP COVER

- (a) Install the oil pump cover.
- (b) Using a torx socket wrench, install and torque the three screws.

(Torx socket wrench T30 09042-00010)

Torque: 50 kg-cm (43 in.-lb, 4.9 N-m)

ASSEMBLY OF TRANSFER

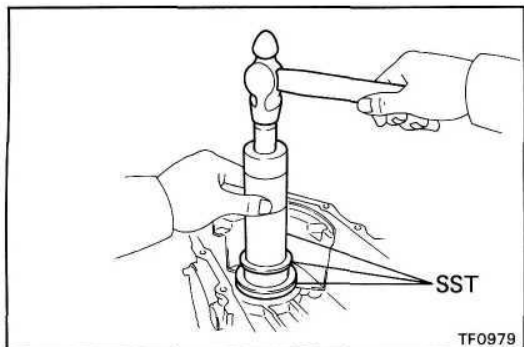

1. INSTALL TWO BEARING RACES TO FRONT CASE

- (a) Using SST and a hammer, install the center differential bearing race.

SST 09316-20011, 09316-60010
(09316-00010, 09316-00030)

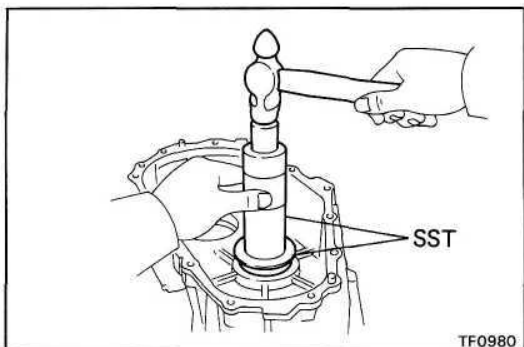

- (b) Using SST and a hammer, install the idler gear bearing race.

SST 09316-60010 (09316-00010, 09316-00040)

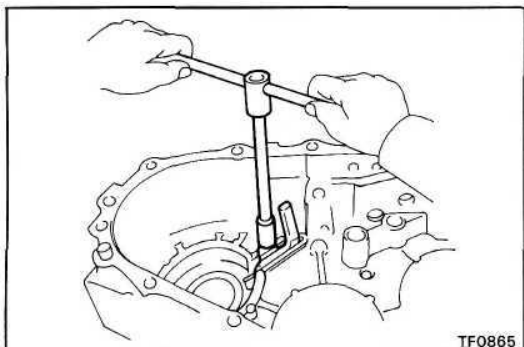

2. INSTALL OIL RECEIVER TO FRONT CASE

- (a) Install the oil receiver.
(b) Install and torque the bolt.

Torque: 55 kg-cm (48 in.-lb, 5.4 N-m)

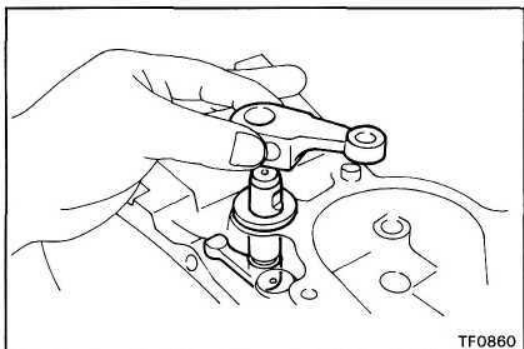

3. INSTALL SHIFT OUTER LEVER, INNER LEVER AND WASHER

- (a) Install the shift outer lever, inner lever and washer.

- (b) Using a pin punch, hammer and socket wrench, install the lever lock pin.

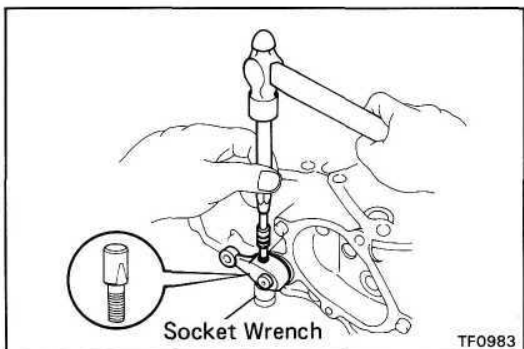

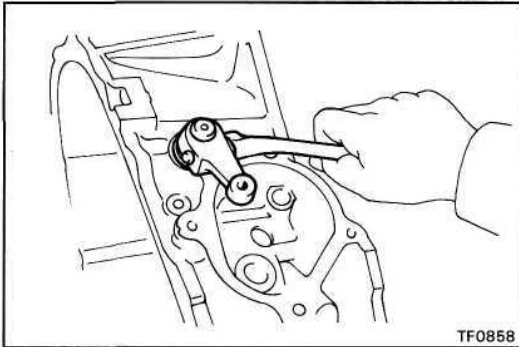

(c) Install the washer and nut.

Torque: 120 kg-cm (9 ft-lb, 12 N·m)

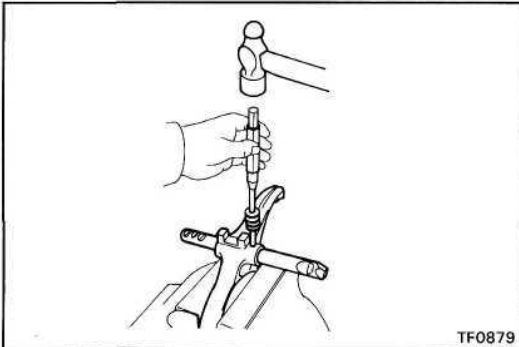

4. ASSEMBLE HIGH AND LOW SHIFT FORK AND FORK SHAFT

Using a pin punch and a hammer, drive in the slotted spring pin.

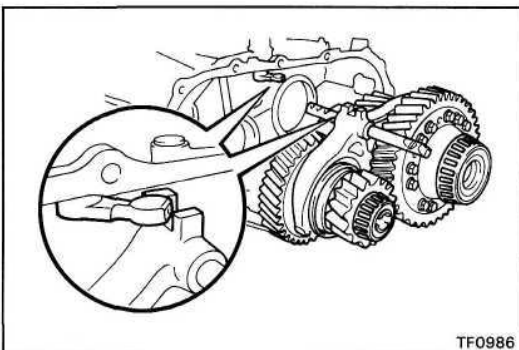

5. INSTALL IDLER GEAR ASSEMBLY, CENTER DIFFERENTIAL ASSEMBLY AND HIGH AND LOW SHIFT FORK ASSEMBLY TO FRONT CASE

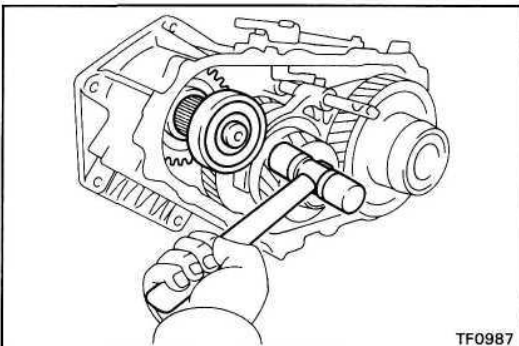

6. INSTALL INPUT SHAFT ASSEMBLY

Using a plastic hammer, tap in the input shaft.

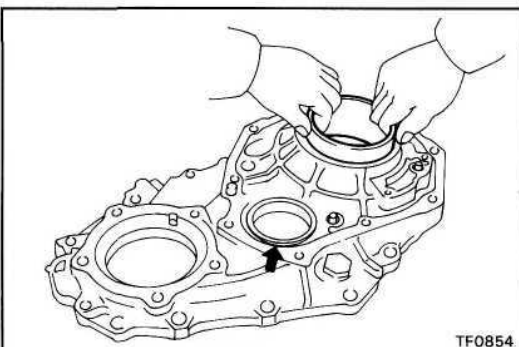

7. INSTALL TWO BEARING RACES TO REAR CASE

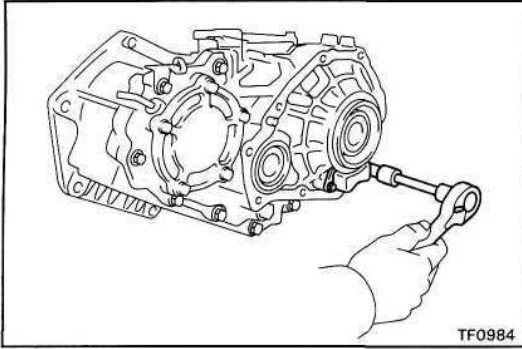

8. INSTALL OIL STRAINER TO REAR CASE

- (a) Install the oil strainer.
- (b) Install and torque the bolts.

Torque: 50 kg-cm (43 in.-lb, 4.9 N-m)

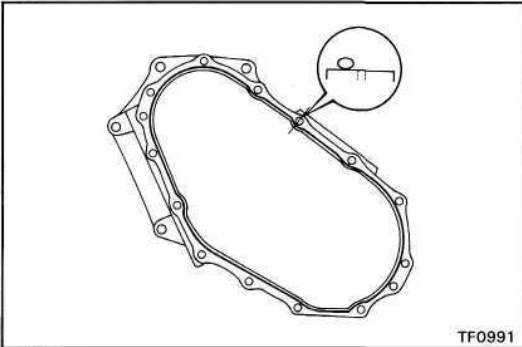

9. ASSEMBLE FRONT CASE AND REAR CASE

- (a) Remove any packing material and be careful not to drop oil on the contacting surfaces of the front case.
- (b) Apply seal packing to the front case as shown.

Seal packing: Part No.08826-00090. THREE BOND 1281 or equivalent

HINT: Install the rear case as soon as the seal packing is applied.

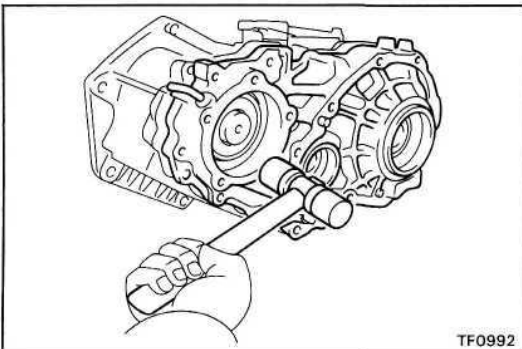

- (c) Using a plastic hammer, tap the rear case and assemble it.

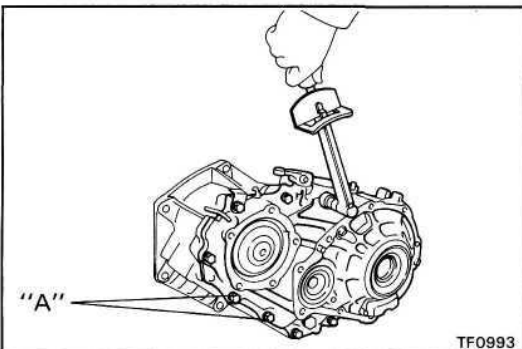

- (d) Apply liquid sealer to the "A" bolt threads.

Sealant: Part No.08833-00080, THREE BOND 1344, LOCTITE 242 or equivalent

- (e) Install and torque the eight bolts.

Torque: 380 kg-cm (27 ft-lb, 37 N-m)

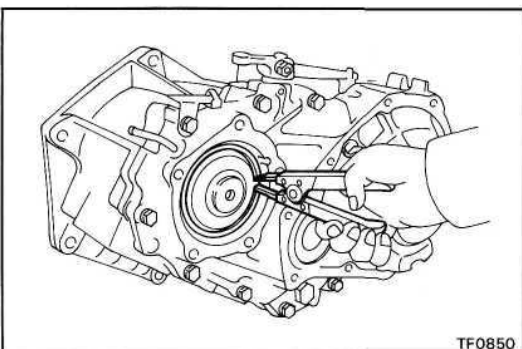

- (f) Using snap ring pliers, install the snap ring.

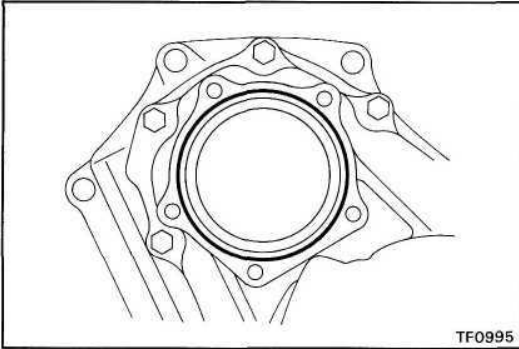

10. INSTALL CASE COVER

- (a) Remove any packing material and be careful not to drop oil on the contacting surfaces of the rear case.
- (b) Apply seal packing to the rear case as shown.

Seal packing: Part No.08826-00090, THREE BOND 1281 or equivalent

HINT: Install the case cover as soon as the seal packing is applied.

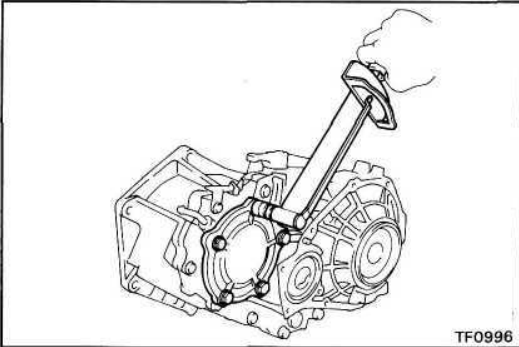

- (c) Install the case cover.
- (d) Apply liquid sealer to the bolt threads.

Sealant: Part No.08833-00080, THREE BOND 1344. LOCTITE 242 or equivalent

- (e) Install and torque the five bolts.

Torque: 380 kg-cm (27 ft-lb, 37 N-m)

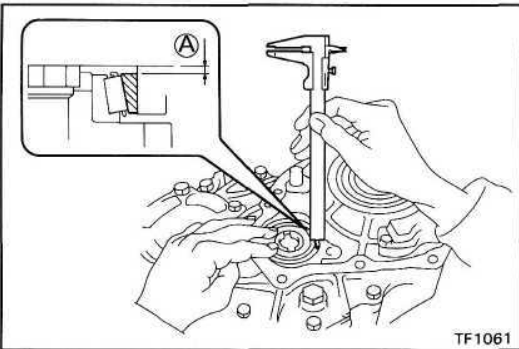

11. SELECT ADJUSTING SHIMS FOR IDLER GEAR REAR TAPER ROLLER BEARING

- (a) Using a vernier caliper with depth gauge, measure dimension **A**.

HINT: Lightly hold down the bearing outer race in the thrust direction to eliminate any looseness before making the measurement.

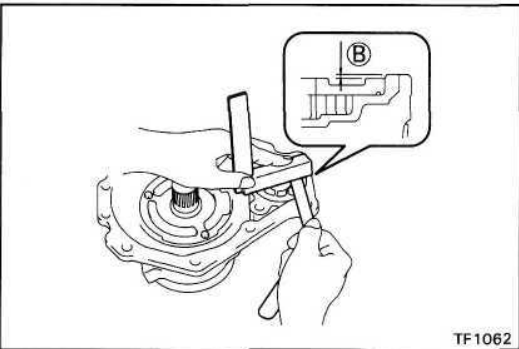

- (b) Using a steel straight edge and feeler gauge, measure the clearance of dimension **B**.
- (c) Calculate the required thickness of the adjusting shim.

Thickness:

Dimension **A + Dimension **B** + (0.03 ~ 0.08 mm)**

- (d) From the following table, select a shim with a thickness fitting within the range of the calculation in (c).

| Mark | Thickness mm (in.) | Mark | Thickness mm (in.) |
|------|--------------------|------|--------------------|
| A | 0.15 (0.0059) | G | 3.00 (0.1181) |
| B | 0.30 (0.0118) | H | 3.20 (0.1260) |
| C | 0.45 (0.0177) | J | 3.40 (0.1339) |
| D | 2.40 (0.0945) | K | 3.60 (0.1417) |
| E | 2.60 (0.1024) | L | 3.80 (0.1496) |
| F | 2.80 (0.1102) | M | 4.00 (0.1575) |

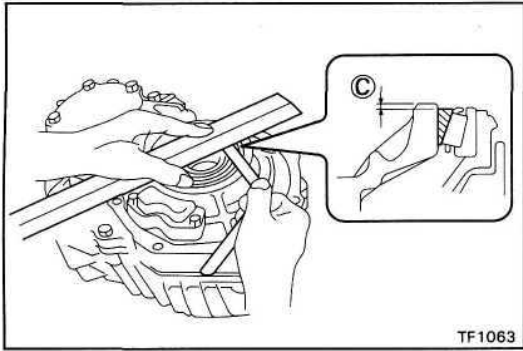

12. SELECT ADJUSTING SHIMS FOR OUTPUT SHAFT TAPER ROLLER BEARING

- (a) Using a steel straight edge and feeler gauge, measure the clearance of dimension C.

HINT: Lightly hold down the bearing outer race in the thrust direction to eliminate any looseness before making the measurement.

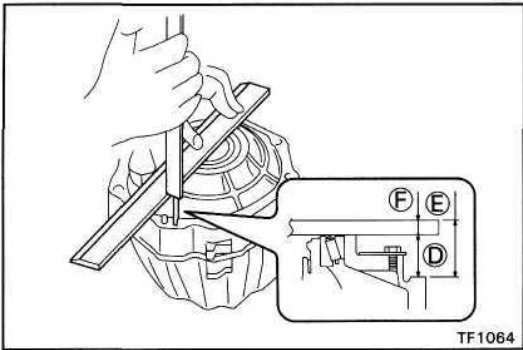

- (b) Using a steel straight edge and vernier caliper with depth gauge, measure dimension D.

HINT: Dimension D is the straight edge thickness (Dimension F) subtracted from dimension E in the illustration to the left.

Dimension D : Dimension E — Dimension F

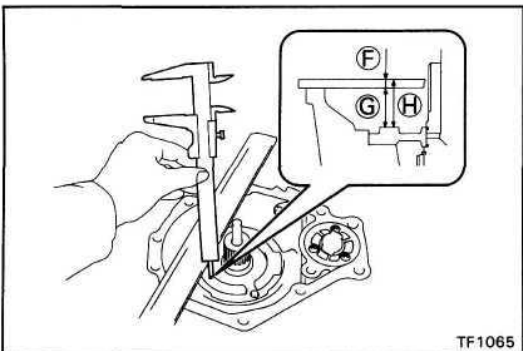

- (c) Using a steel straight edge and vernier caliper with depth gauge, measure dimension G.

HINT: Dimension G is the straight edge thickness (Dimension F) subtracted from Dimension H

Dimension G : Dimension H — Dimension F

- (d) Calculate the required thickness of the adjusting shim.

Thickness: Dimension G — (Dimension D — Dimension C) + (0.02 ~ 0.07 mm)

- (e) From the following table, select a shim with a thickness fitting within the range of the calculation in (d).

| Mark | Thickness mm (in.) | Mark | Thickness mm (in.) |
|------|--------------------|------|--------------------|
| A | 0.15 (0.0059) | G | 1.60 (0.0630) |
| B | 0.30 (0.0118) | H | 1.80 (0.0709) |
| C | 0.45 (0.0177) | J | 2.00 (0.0787) |
| D | 1.00 (0.0394) | K | 2.20 (0.0866) |
| E | 1.20 (0.0472) | L | 2.40 (0.0945) |
| F | 1.40 (0.0551) | M | 2.60 (0.1024) |

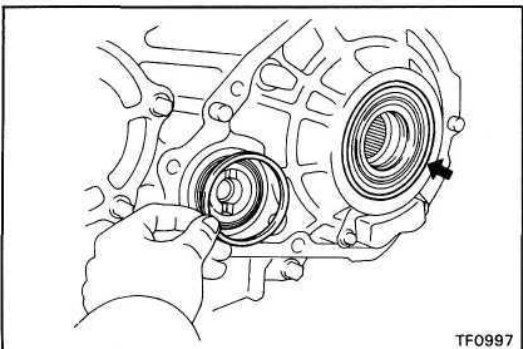

13. INSTALL ADJUSTING SHIMS TO IDLER GEAR AND OUTPUT SHAFT TAPER ROLLER BEARINGS

- (a) Apply MP grease to the adjusting shims.
- (b) Install the adjusting shims to bearing outer races.

HINT: Install the thinnest shim on the bearing outer race side.

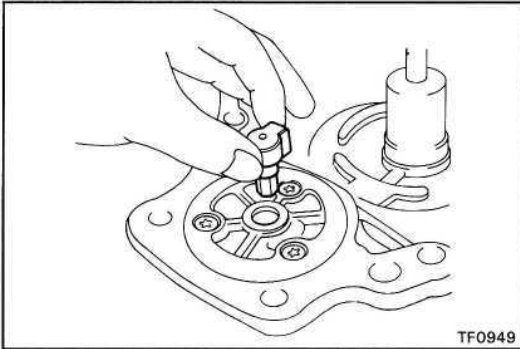
**14. INSTALL REAR EXTENSION HOUSING**

- (a) Install the oil pump drive shaft.

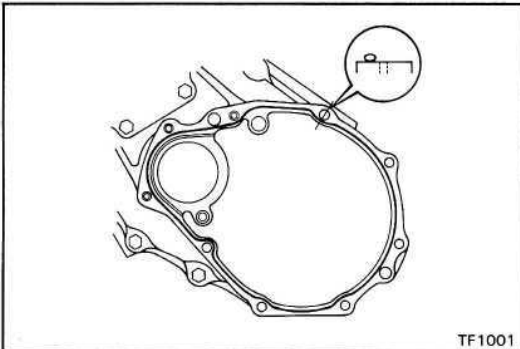

- (b) Remove any packing material and be careful not to drop oil on the contacting surfaces of the rear case.

- (c) Apply seal packing to the rear case as shown.

Seal packing: Part No.08826-00090, THREE BOND 1281 or equivalent

HINT: Install the rear extension housing as soon as the seal packing is applied.

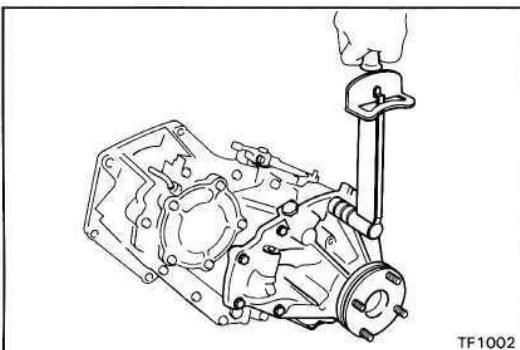

- (d) Install the rear extension housing.

- (e) Install and torque the nine bolts.

Torque: 380 kg-cm (27 ft-lb, 37 N-m)

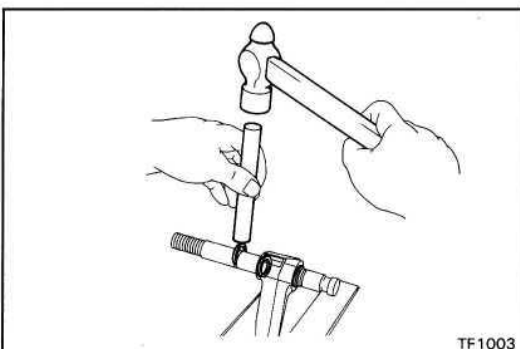
**15. ASSEMBLE SHIFT FORK NO.2 AND FORK SHAFT**

- (a) Assemble the shift fork No.2 and fork shaft.

- (b) Using a brass bar and hammer, tap in the snap rings.

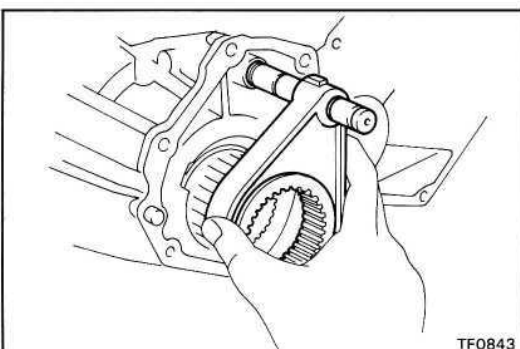
**16. INSTALL CLUTCH SLEEVE, SHIFT FORK NO.2 AND FORK SHAFT**

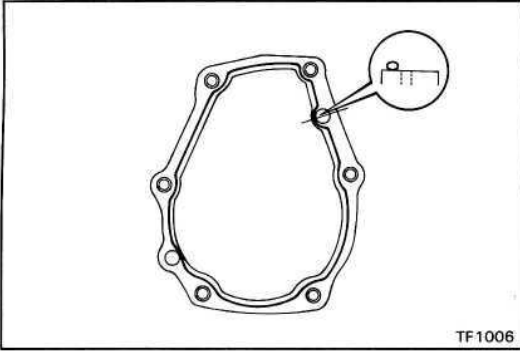

TF1006

17. INSTALL FRONT EXTENSION HOUSING

- (a) Remove any packing material and be careful not to drop oil on the contacting surfaces of the front case.
- (b) Apply seal packing to the front case as shown.

Seal packing: Part No.08826-00090, THREE BOND 1281 or equivalent

HINT: Install the front extension housing as soon as the seal packing is applied.

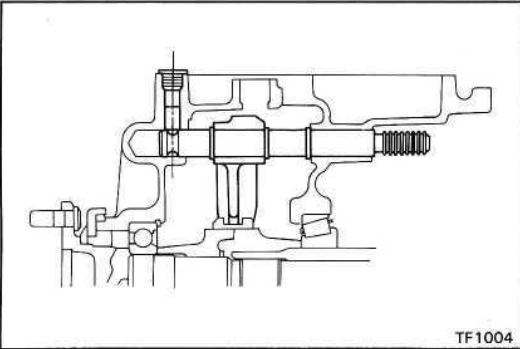

TF1004

- (c) Set the clutch sleeve in 4WD condition, install the front extension housing.

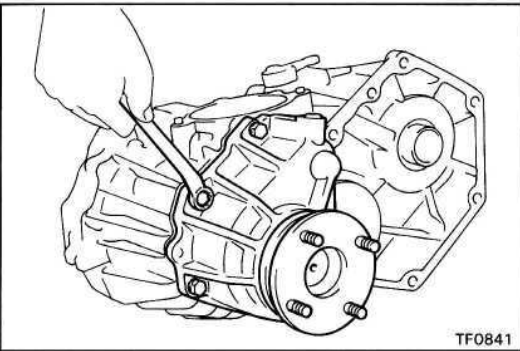

TF0841

- (d) Install and torque the six bolts.

Torque: 380 kg-cm (27 ft-lb, 37 Nm)

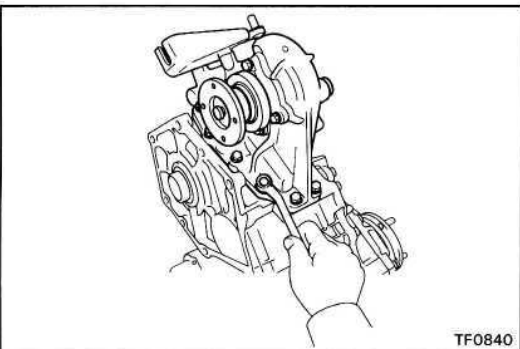

TF0840

18. (w/POWER TAKE-OFF) INSTALL POWER TAKE-OFF CASE

- (a) Install the power take-off case and a new gasket.
- (b) Apply liquid sealer to the bolt threads.

Sealant: Part No.08833-00080, THREE BOND 1344, LOCTITE 242 or equivalent

- (c) Install and torque the ten bolts.

Torque: 195 kg-cm (14 ft-lb, 19 Nm)

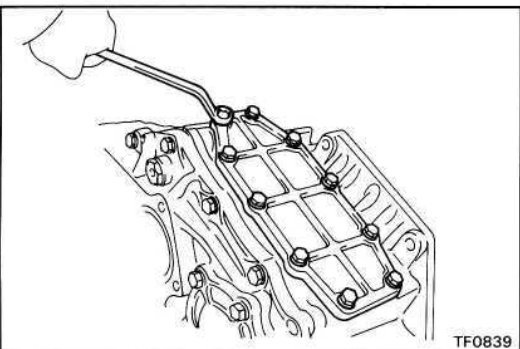

TF0839

19. (w/o POWER TAKE-OFF) INSTALL POWER TAKE-OFF COVER

- (a) Install the power take-off cover and a new gasket.
- (b) Apply liquid sealer to the bolt threads.

Sealant: Part No.08833-00080, THREE BOND 1344, LOCTITE 242 or equivalent

- (c) Install and torque the ten bolts.

Torque: 195 kg-cm (14 ft-lb, 19 Nm)

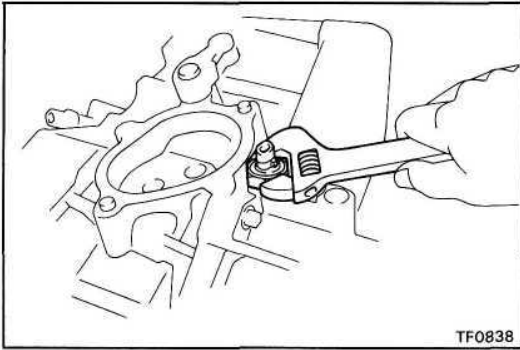
**20. INSTALL 4WD INDICATOR SWITCH**

Install and torque the transfer indicator switch.

Torque: 380 kg-cm (27 ft-lb, 37 N-m)

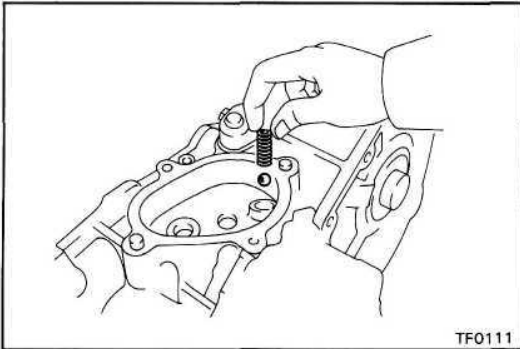
**21. INSTALL BALL, SPRING AND SCREW PLUG**

(a) Install the ball and spring.

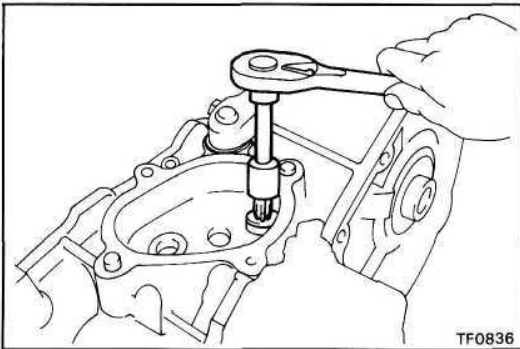

(b) Apply liquid sealer to the screw plug.

Sealant: Part No.08833-00080, THREE BOND 1344, LOCTITE 242 or equivalent

(c) Using a torx socket wrench, install and torque the screw plug.

(Torx socket wrench T40 09042-00020)

Torque: 190 kg-cm (14 ft-lb, 19 N-m)

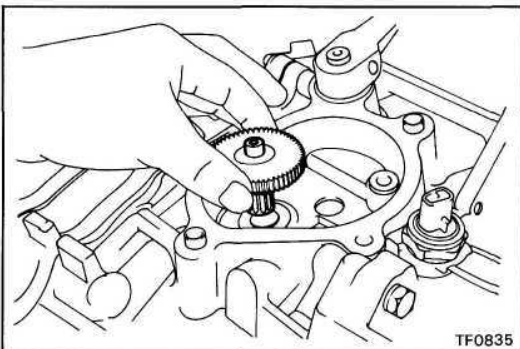
**22. INSTALL OUTPUT GEAR**

(a) Apply gear oil to the output gear.

(b) Install the output gear.

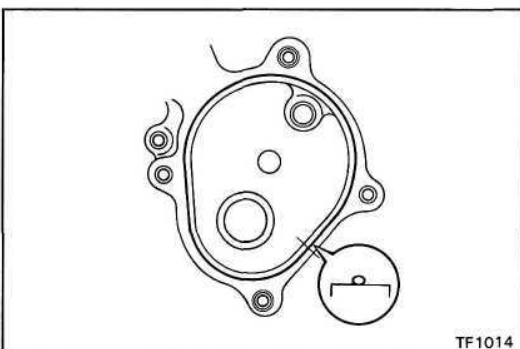
**23. INSTALL MOTOR ACTUATOR**

(a) Remove any packing material and be careful not to drop oil on the contacting surfaces of the front case.

(b) Apply seal packing to the front case as shown.

Seal packing: Part No.08826-00090, THREE BOND 1281 or equivalent

HINT: Install the motor actuator as soon as the seal packing is applied.

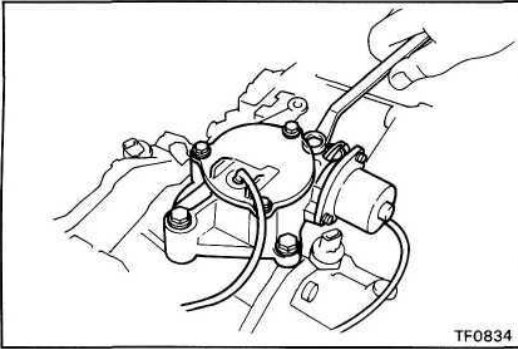

(c) Install the motor actuator.

HINT: Set the motor actuator in differential lock condition.

(d) Install and torque the four bolts.

Torque: 195 kg-cm (14 ft-lb, 19 Nm)

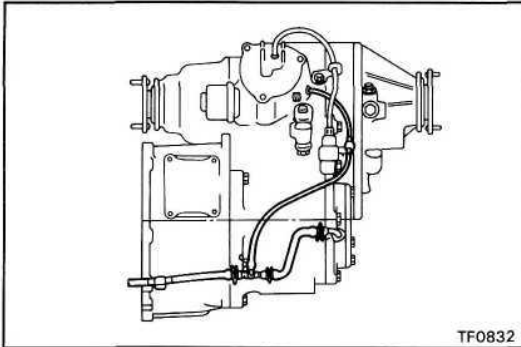

24. INSTALL BREATHER HOSE

(PART-TIME 4WD TYPE TRANSFER) COMPONENTS

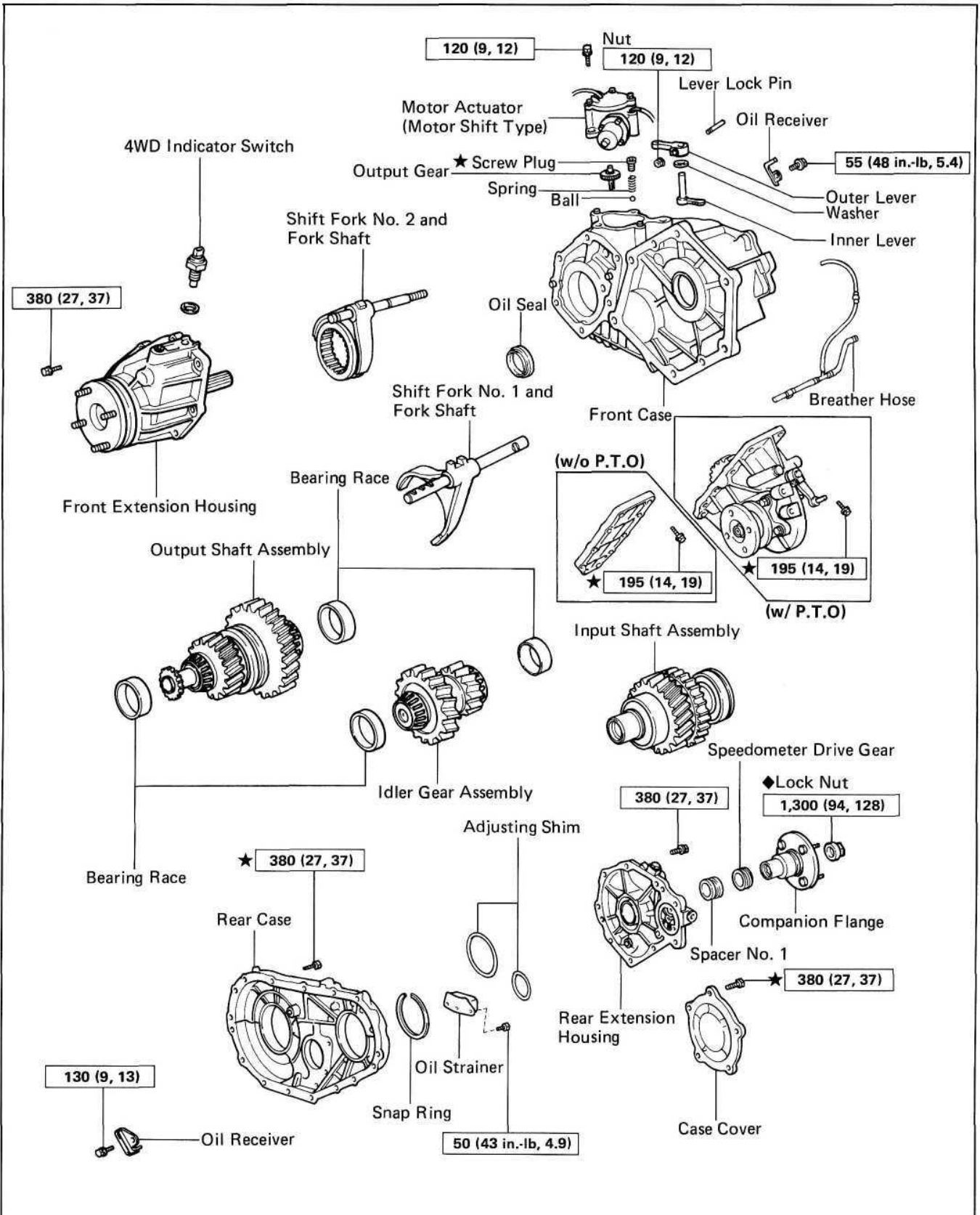

kg-cm (ft-lb, N·m) : Specified torque
 ◆ Non-reusable part

DISASSEMBLY OF TRANSFER

(See page TF-49)

1. REMOVE BREATHER HOSE

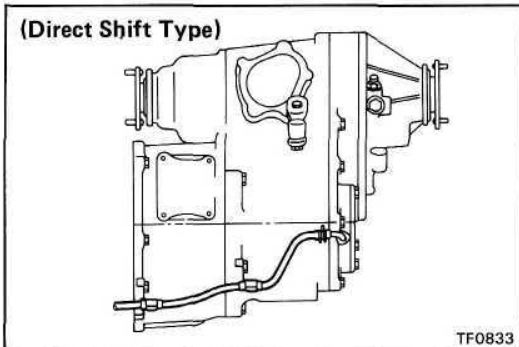
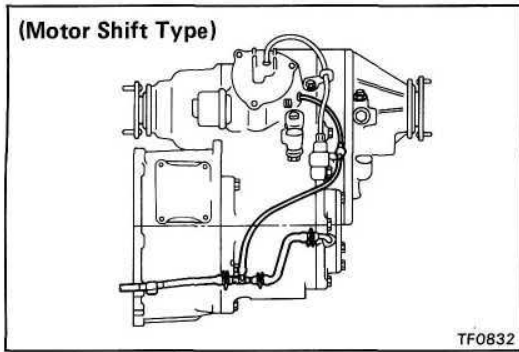

2. (MOTOR SHIFT TYPE) REMOVE MOTOR ACTUATOR

Remove the four bolts and motor actuator.

HINT: Set the motor actuator in differential lock condition.

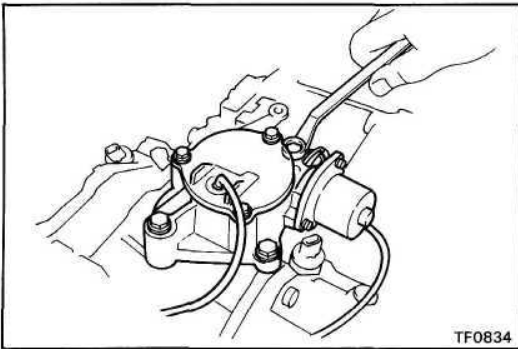

3. (MOTOR SHIFT TYPE) REMOVE OUTPUT GEAR

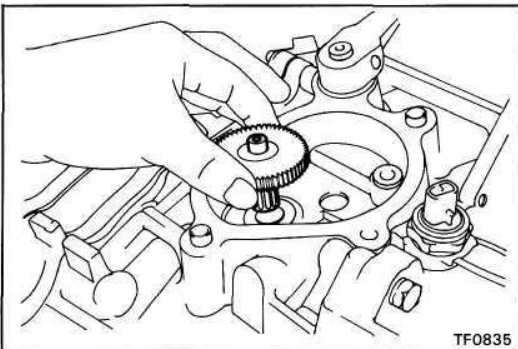

4. REMOVE SCREW PLUG, SPRING AND BALL

(a) Using a torx socket wrench, remove the screw plug.

(Torx socket wrench T40 09042-00020)

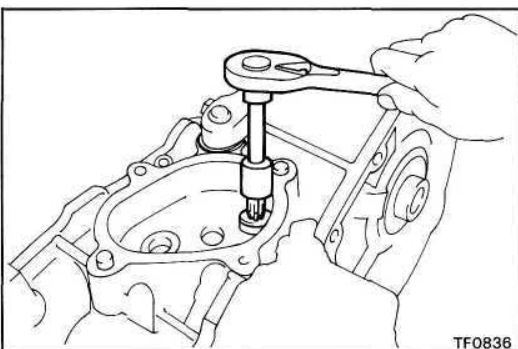

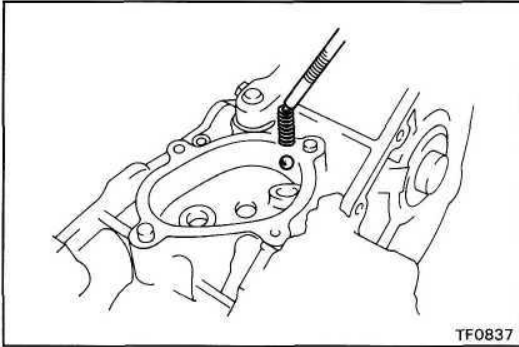

- (b) Using a magnetic finger, remove the spring and ball.

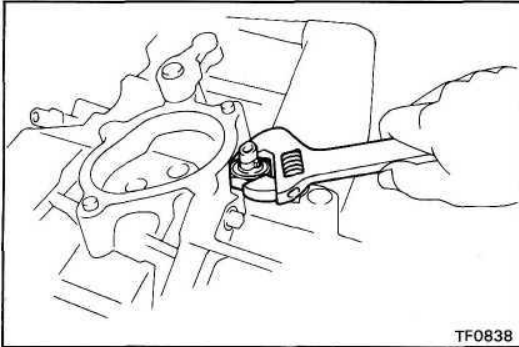

5. REMOVE 4WD INDICATOR SWITCH

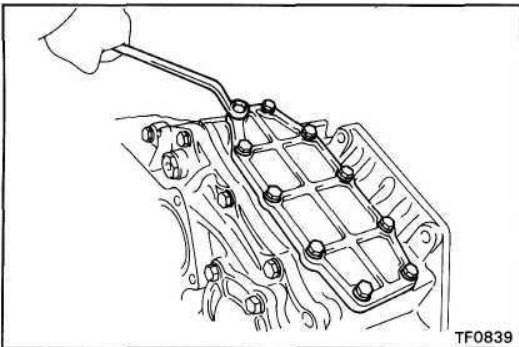

**6. (w/o POWER TAKE-OFF)
REMOVE POWER TAKE-OFF COVER**

Remove the ten bolts, power take-off cover and gasket.

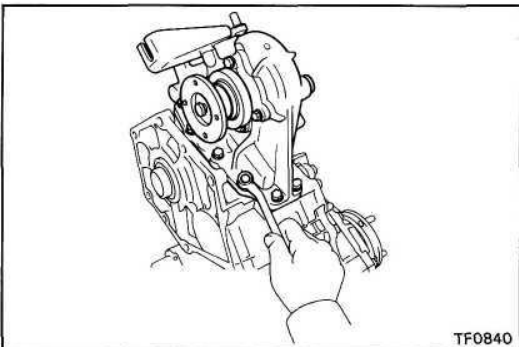

**7. (w/ POWER TAKE-OFF)
REMOVE POWER TAKE-OFF CASE**

Remove the ten bolts, power take-off case and gasket.

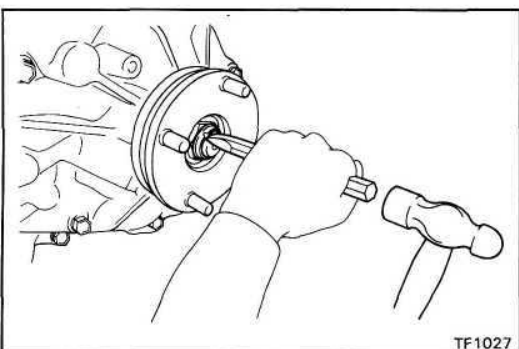

8. REMOVE OUTPUT SHAFT COMPANION FLANGE

- (a) Using a hammer and chisel, loosen the staked part of the nut.

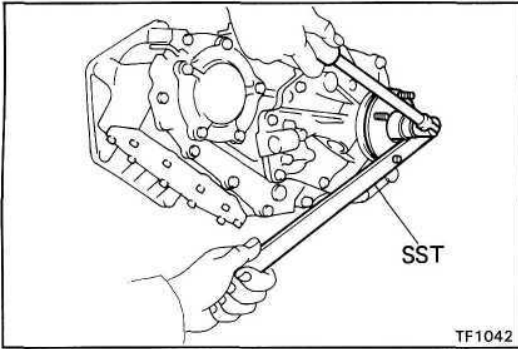

TF1042

- (b) Using SST to hold the flange, remove the nut and washer.

SST 09330-00021

- (c) Remove the companion flange.

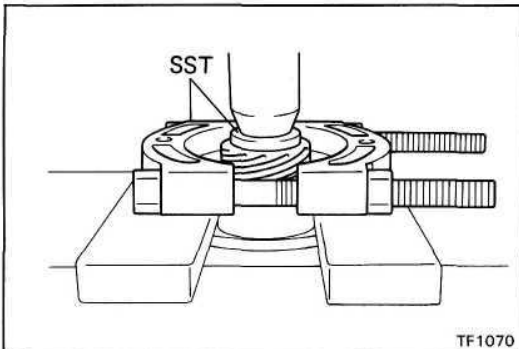

TF1070

9. REMOVE SPEEDOMETER DRIVE GEAR AND DUST DEFLECTOR FROM OUTPUT SHAFT COMPANION FLANGE

- (a) Using SST and a press, remove the speedometer drive gear.

SST 09608-20012 (09608-00040), 09950-00020

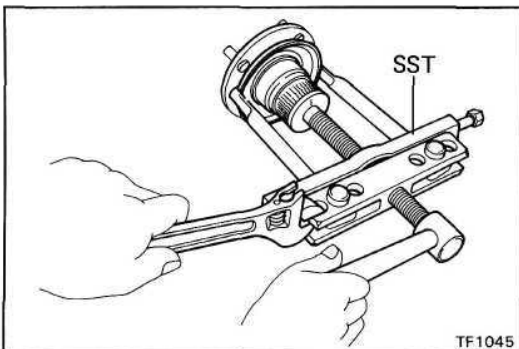

TF1045

- (b) Using SST, remove the dust deflector.

SST 09950-20017

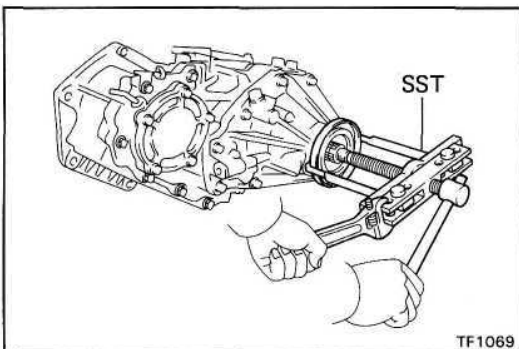

TF1069

10. REMOVE DUST DEFLECTOR FROM REAR EXTENSION HOUSING

Using SST, remove the dust deflector.

SST 09950-20017

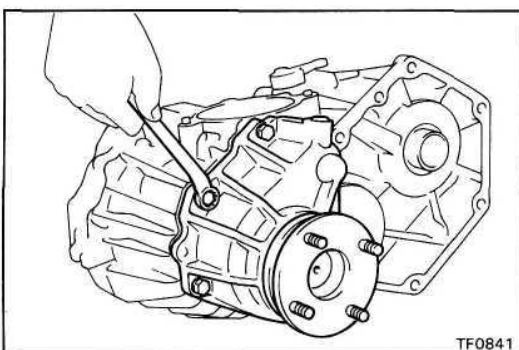

TF0841

11. REMOVE FRONT EXTENSION HOUSING

Remove the six bolts and front extension housing.

HINT: If necessary, tap the front extension housing with a plastic hammer.

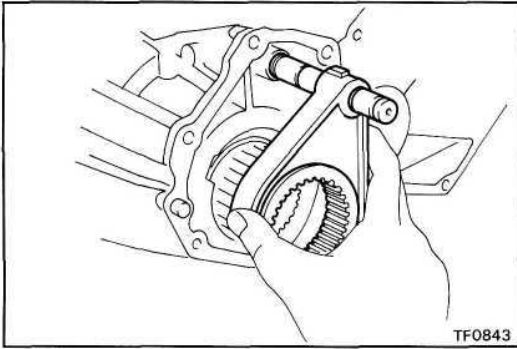

- 12. REMOVE CLUTCH SLEEVE, SHIFT FORK NO.2 AND FORK SHAFT**

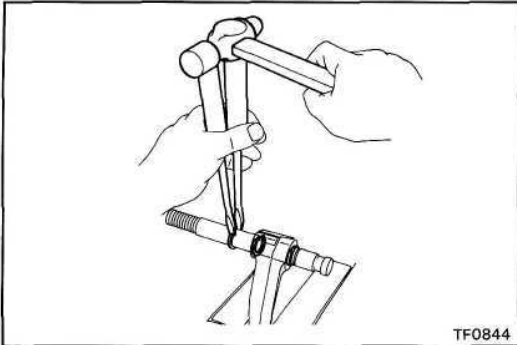

- 13. SEPARATE SHIFT FORK NO.2 AND FORK SHAFT**

(Motor shift type)

- (a) Using two screwdrivers and a hammer, tap out the snap rings.
- (b) Separate the shift fork No.2 and fork shaft.

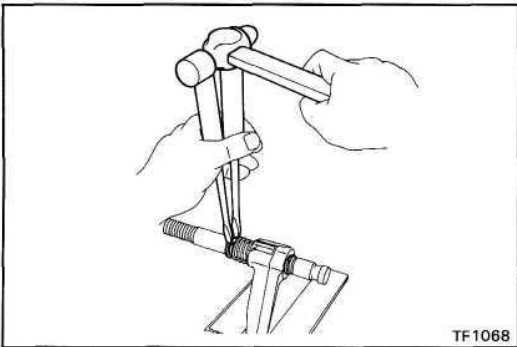

(Direct shift type)

- (a) Using two screwdrivers and a hammer, tap out the snap rings.
- (b) Separate the shift fork No.3, fork shaft and spring.

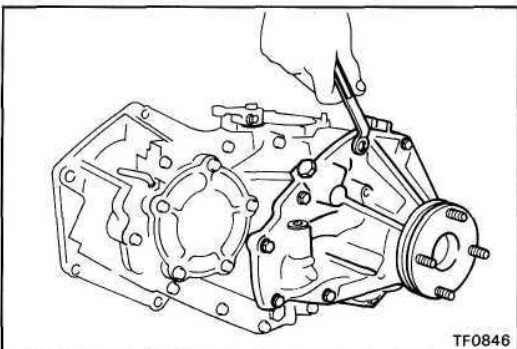

- 14. REMOVE REAR EXTENSION HOUSING**

Remove the nine bolts and rear extension housing.

HINT: Using a plastic hammer, tap the rear extension housing and remove it.

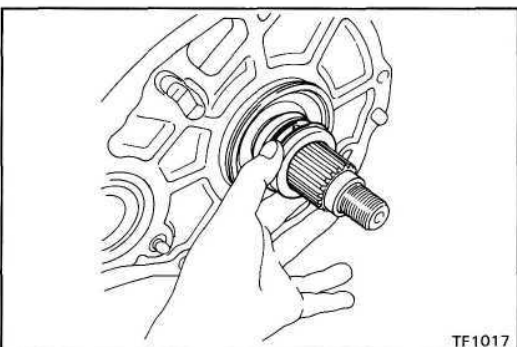

- 15. REMOVE SPACER NO.1, BALL AND SHIMS**

- (a) Remove the spacer No. 1.
- (b) Using a magnetic finger, remove the ball.
- (c) Remove the shims.

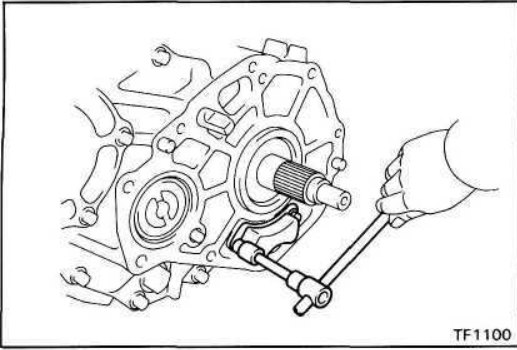
**16. REMOVE OIL STRAINER FROM REAR CASE**

Remove the two set bolts and oil strainer.

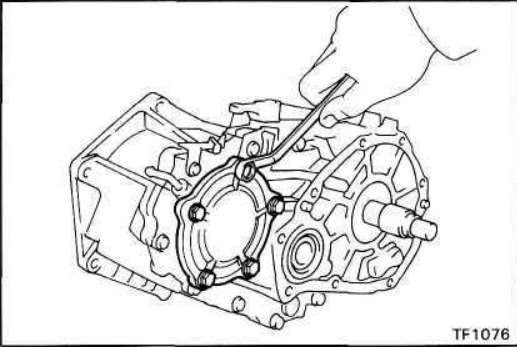
**17. REMOVE CASE COVER**

(a) Remove the five bolts.

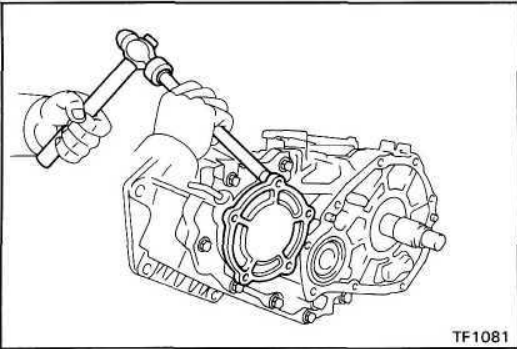

(b) Using a brass bar and hammer, remove the case cover.

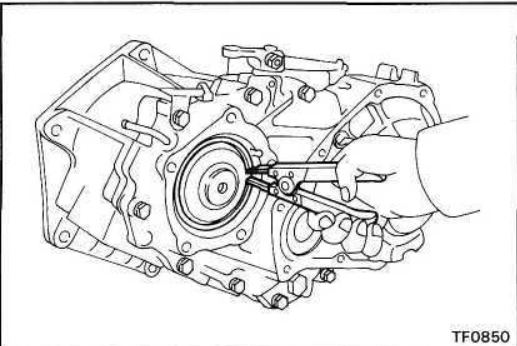
**18. SEPARATE FRONT CASE AND REAR CASE**

(a) Using snap ring pliers, remove the snap ring.

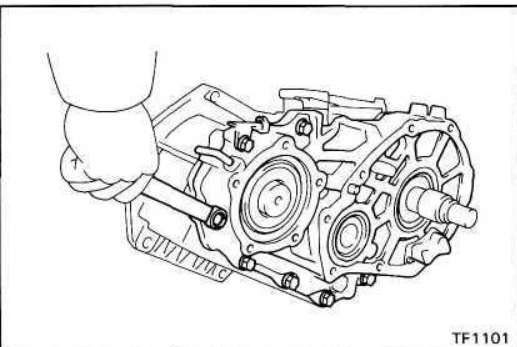

(b) Remove the eight bolts.

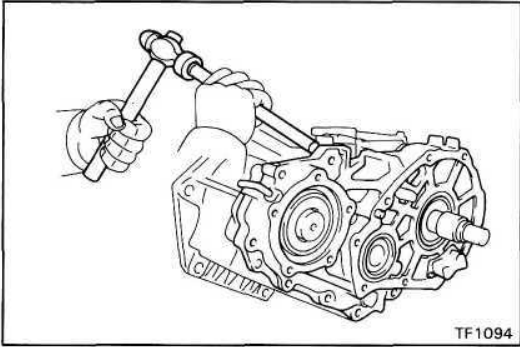

- (c) Using a brass bar and hammer, tap the rear case and separate it.

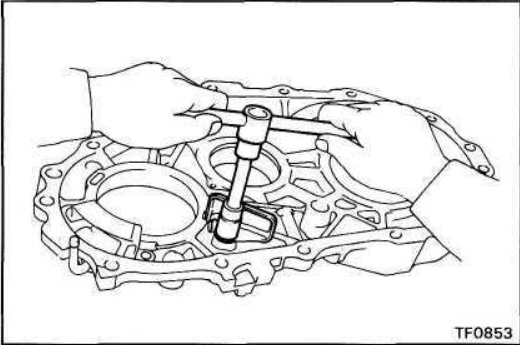

19. REMOVE OIL RECEIVER FROM REAR CASE

Remove the set bolt and oil receiver.

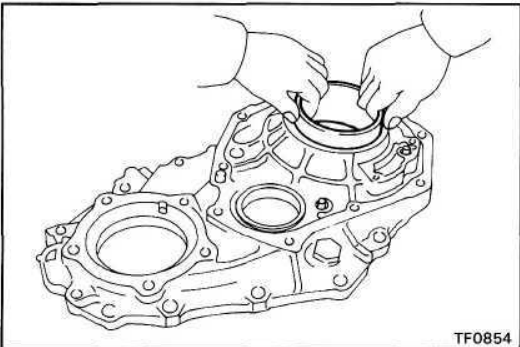

20. REMOVE TWO BEARING RACES FROM REAR CASE

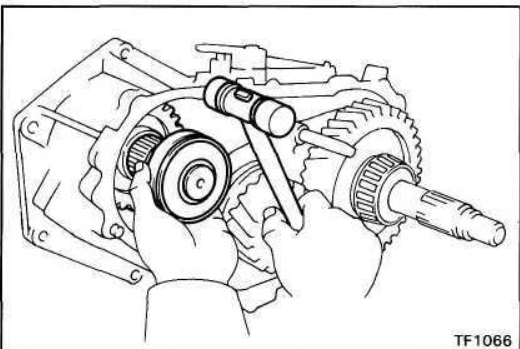

21. REMOVE INPUT SHAFT ASSEMBLY

Using a plastic hammer, tap the front case and remove the input shaft.

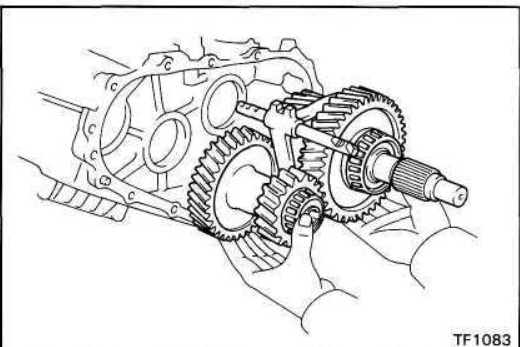

22. REMOVE IDLE GEAR ASSEMBLY, OUTPUT SHAFT ASSEMBLY, SHIFT FORK N0.1 AND FORK SHAFT

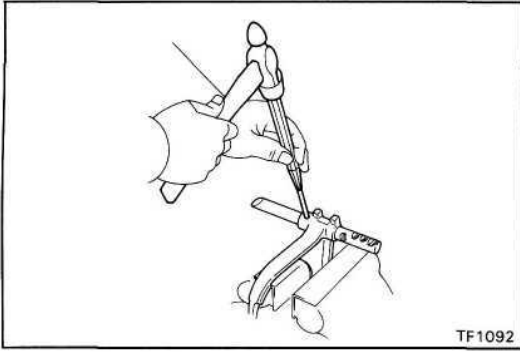

23. SEPARATE SHIFT FORK NO.1 AND FORK SHAFT

- (a) Using a pin punch and hammer, drive out the slotted spring pin.
- (b) Separate the shift fork No.1 and fork shaft.

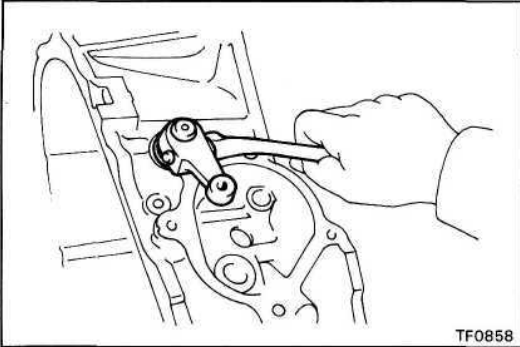

24. REMOVE SHIFT OUTER LEVER AND INNER LEVER

- (a) Remove the nut and washer.

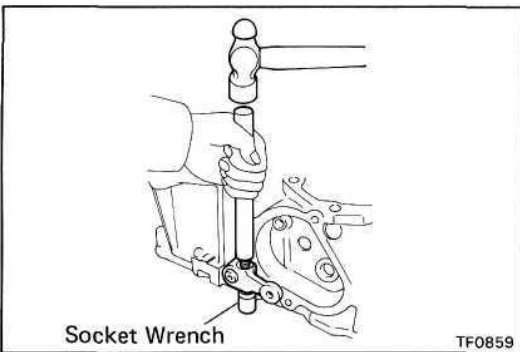

- (b) Using a brass bar and hammer, tap out the lever lock pin.

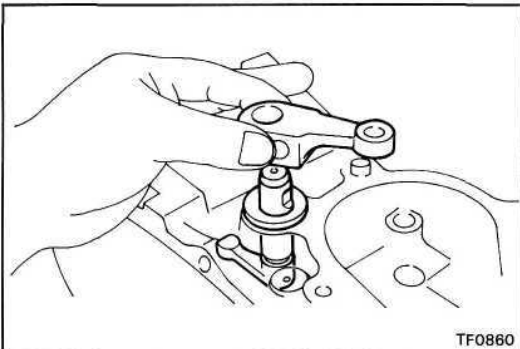

- (c) Remove the shift outer lever and inner lever.

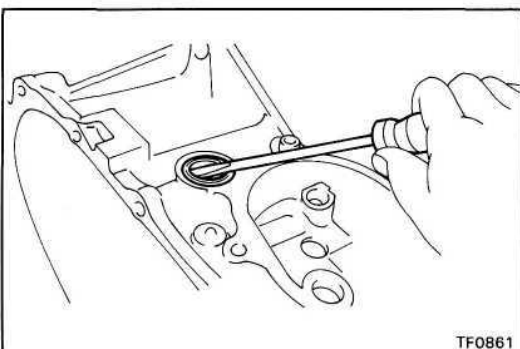

25. IF NECESSARY, REPLACE SHIFT LEVER OIL SEAL

- (a) Using a screwdriver, pry out the oil seal.

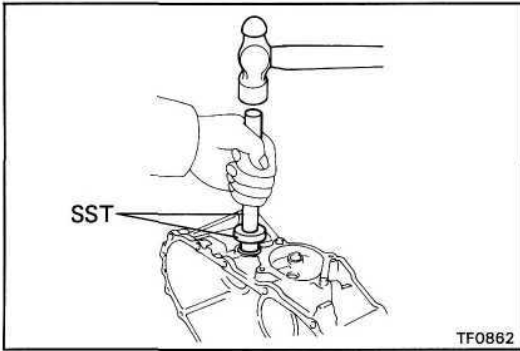

- (b) Using SST and a hammer, drive in a new oil seal.
SST 09608-20012 (09608-00080, 09608-03020)

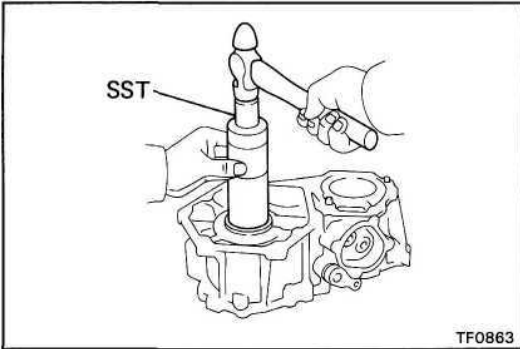

26. IF NECESSARY, REPLACE INPUT SHAFT OIL SEAL

- (a) Using SST and a hammer, drive out the oil seal.
SST 09316-60010 (09316-00010)

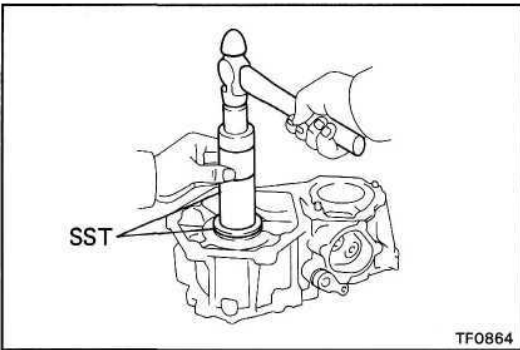

- (b) Using SST and a hammer, drive in a new oil seal.
SST 09316-60010 (09316-00010, 09316-00030)

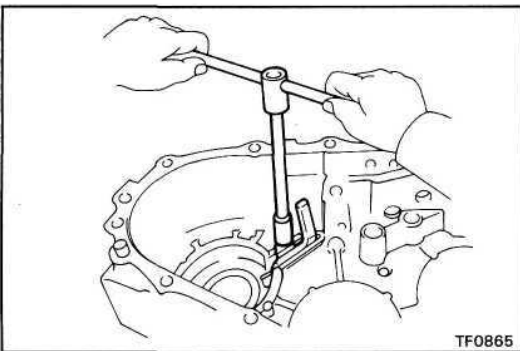

27. REMOVE OIL RECEIVER FROM FRONT CASE

- Remove the set bolt and oil receiver.

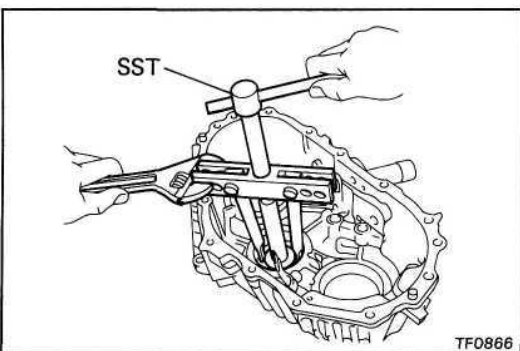

28. REMOVE TWO BEARING RACES FROM FRONT CASE

- (a) Using SST, remove the bearing race.
SST 09950-20017

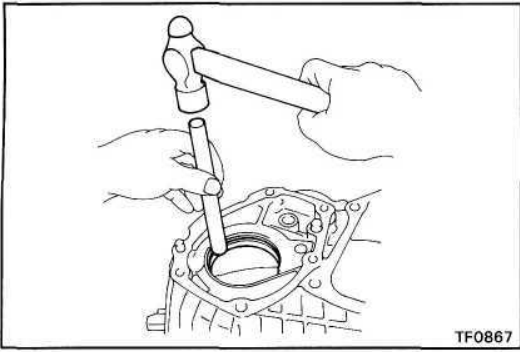

- (b) Using a brass bar and hammer, remove the bearing race.

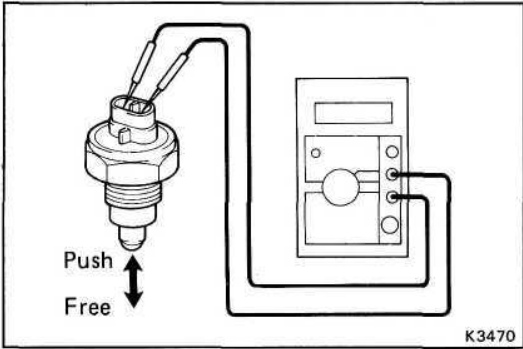

29. INSPECTION OF TRANSFER INDICATOR SWITCH

Check that there is continuity between terminals as shown.

| Switch Position | Specified |
|-----------------|---------------|
| Push | Continuity |
| Free | No continuity |

If operation is not as specified, replace the switch.

COMPONENT PARTS

Input Shaft Assembly

COMPONENTS

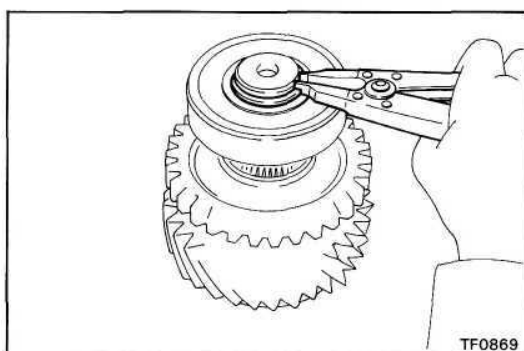
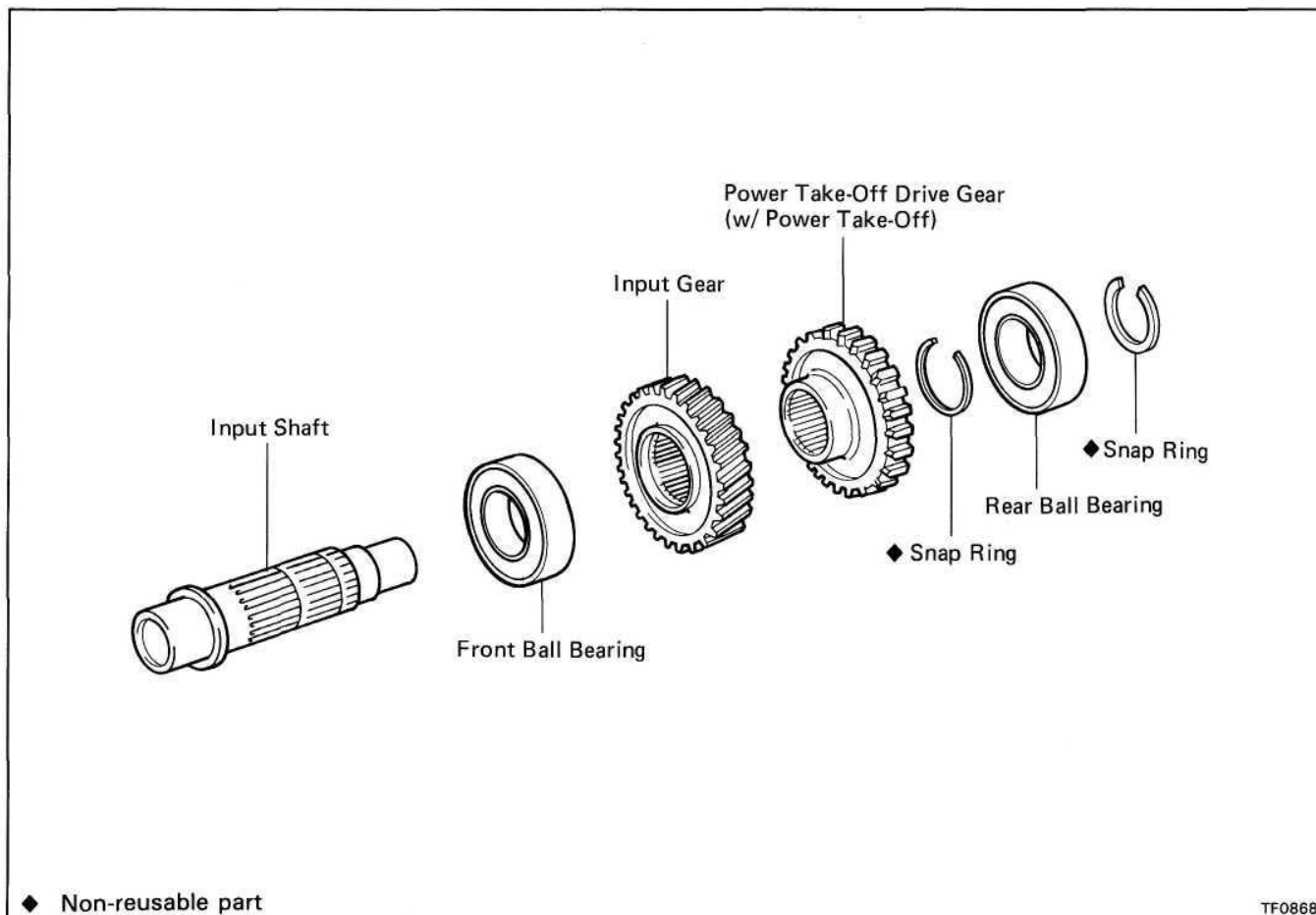

DISASSEMBLY OF INPUT SHAFT ASSEMBLY

1. REMOVE REAR BALL BEARING

(a) Using snap ring pliers, remove the snap ring.

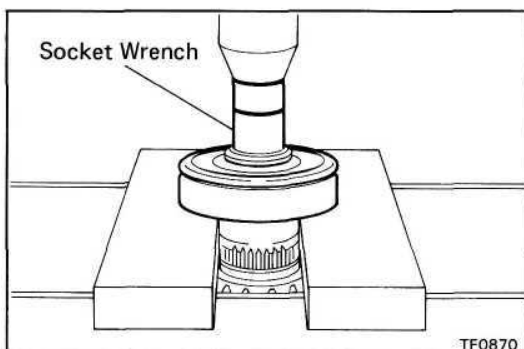

(b) Using a press and socket wrench, remove the rear ball bearing.

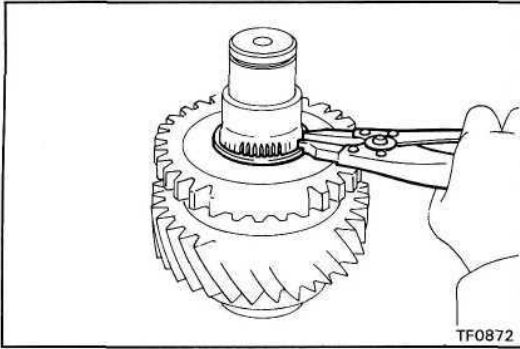

2. **(w/ POWER TAKE-OFF)
REMOVE POWER TAKE-OFF DRIVE GEAR**

(a) Using snap ring pliers, remove the snap ring.

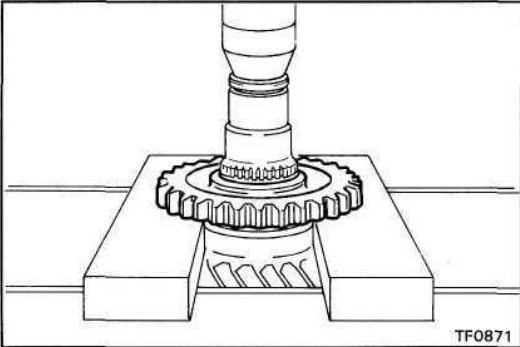

(b) Using a press, remove the power take-off drive gear.

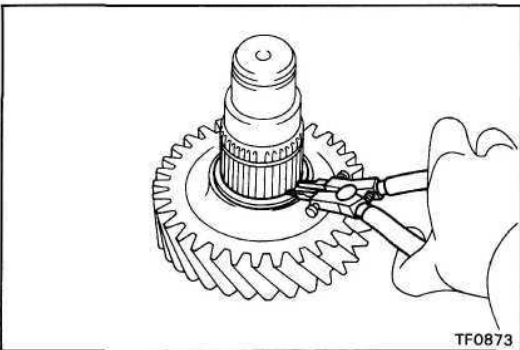

3. **REMOVE INPUT GEAR**

(a) (w/o Power take-off)
Using snap ring pliers, remove the snap ring.

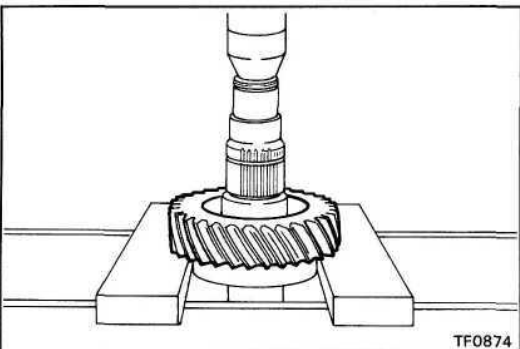

(b) Using a press, remove the input gear.

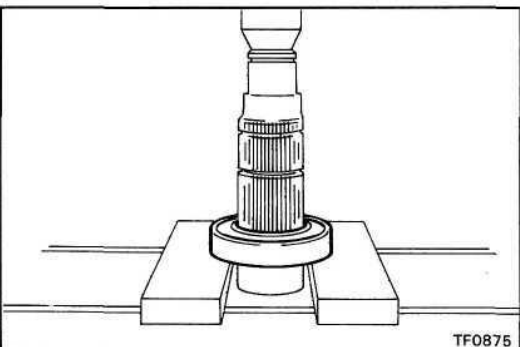

4. **REMOVE FRONT BALL BEARING**

Using a press, remove the front ball bearing.

ASSEMBLY OF INPUT SHAFT ASSEMBLY

1. INSTALL FRONT BALL BEARING

Using a press, install the front ball bearing.

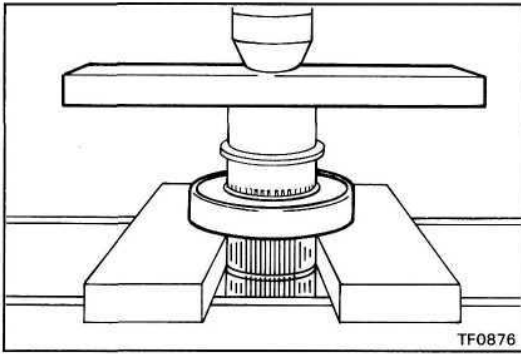

2. INSTALL INPUT GEAR

(a) Using a press, install the input gear.

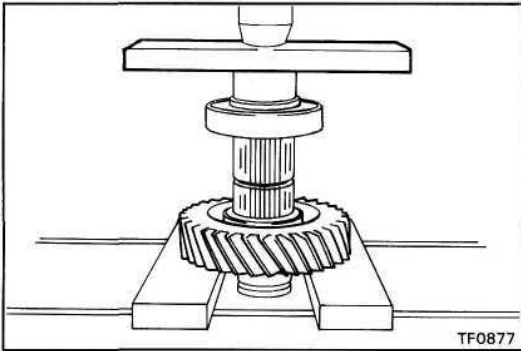

(b) (w/o Power take-off)
Select a snap ring that will allow minimum axial play and install it on the shaft.

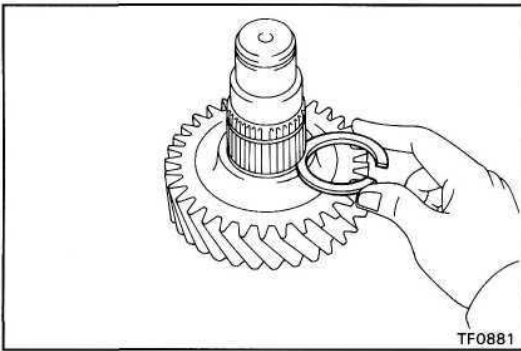

| Mark | Thickness mm (in.) |
|------|--------------------|
| A | 2.0 (0.0787) |
| B | 2.1 (0.0827) |
| C | 2.2 (0.0866) |
| D | 2.3 (0.0906) |
| E | 2.4 (0.0945) |
| F | 2.5 (0.0984) |
| G | 2.6 (0.1024) |
| H | 2.7 (0.1063) |
| J | 2.8 (0.1102) |

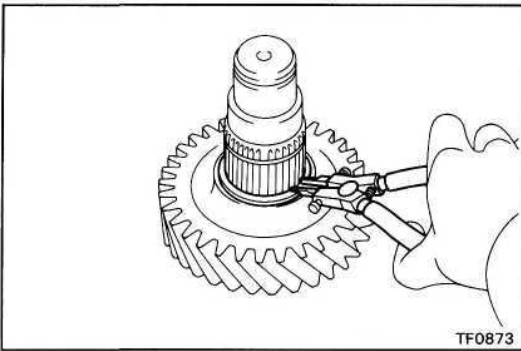

**3. (w/ POWER TAKE-OFF)
INSTALL POWER TAKE-OFF GEAR**

(a) Using a press, install the power take-off gear.

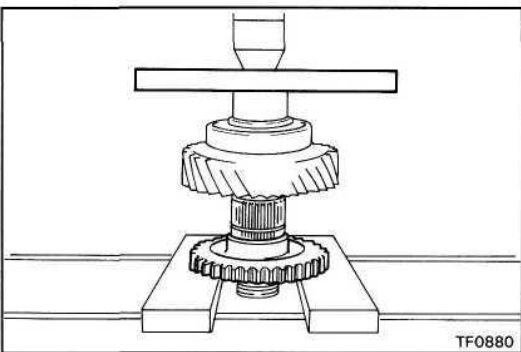

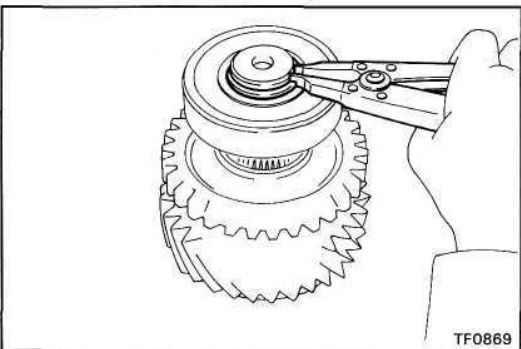
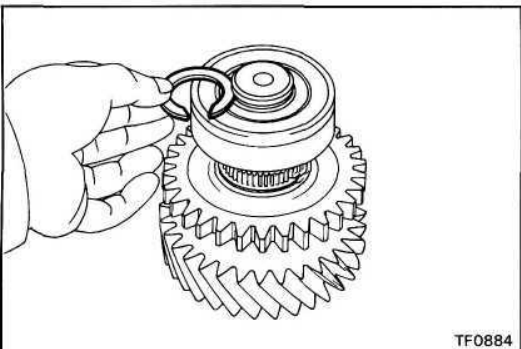
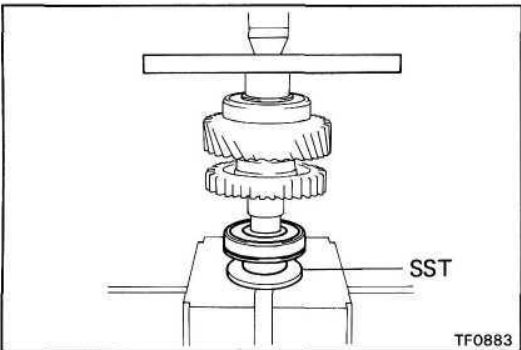
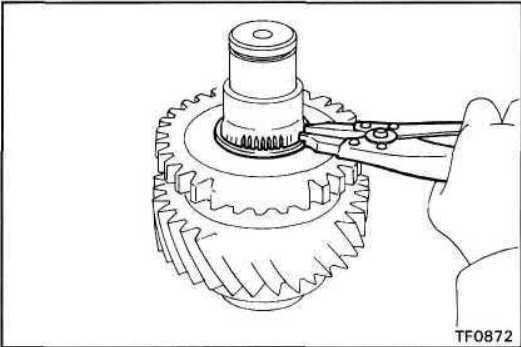
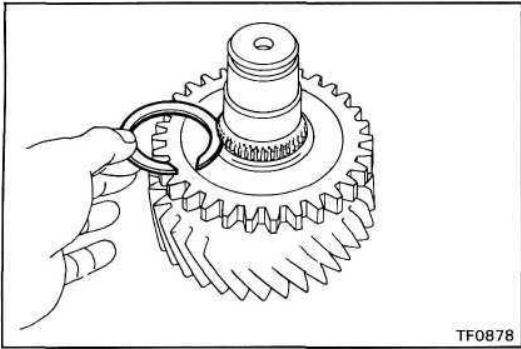

(b) Select a snap ring that will allow minimum axial play and install it on the shaft.

| Mark | Thickness mm (in.) |
|------|--------------------|
| A | 2.0 (0.0787) |
| B | 2.1 (0.0827) |
| C | 2.2 (0.0866) |
| D | 2.3 (0.0906) |
| E | 2.4 (0.0945) |
| F | 2.5 (0.0984) |
| G | 2.6 (0.1024) |
| H | 2.7 (0.1063) |
| J | 2.8 (0.1102) |

4. INSTALL REAR BALL BEARING

(a) Using SST and a press, install the rear ball bearing. SST 09316-60010 (09316-00030)

(b) Select a snap ring that will allow minimum axial play.

| Mark | Thickness mm (in.) |
|------|--------------------|
| A | 2.0 (0.0787) |
| B | 2.1 (0.0827) |
| C | 2.2 (0.0866) |
| D | 2.3 (0.0906) |
| E | 2.4 (0.0945) |

(c) Using snap ring pliers, install the snap ring.

Idler Gear Assembly

COMPONENTS

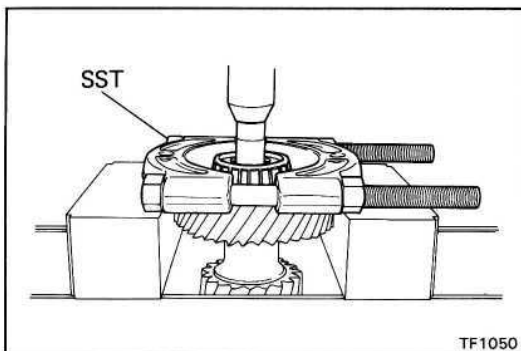
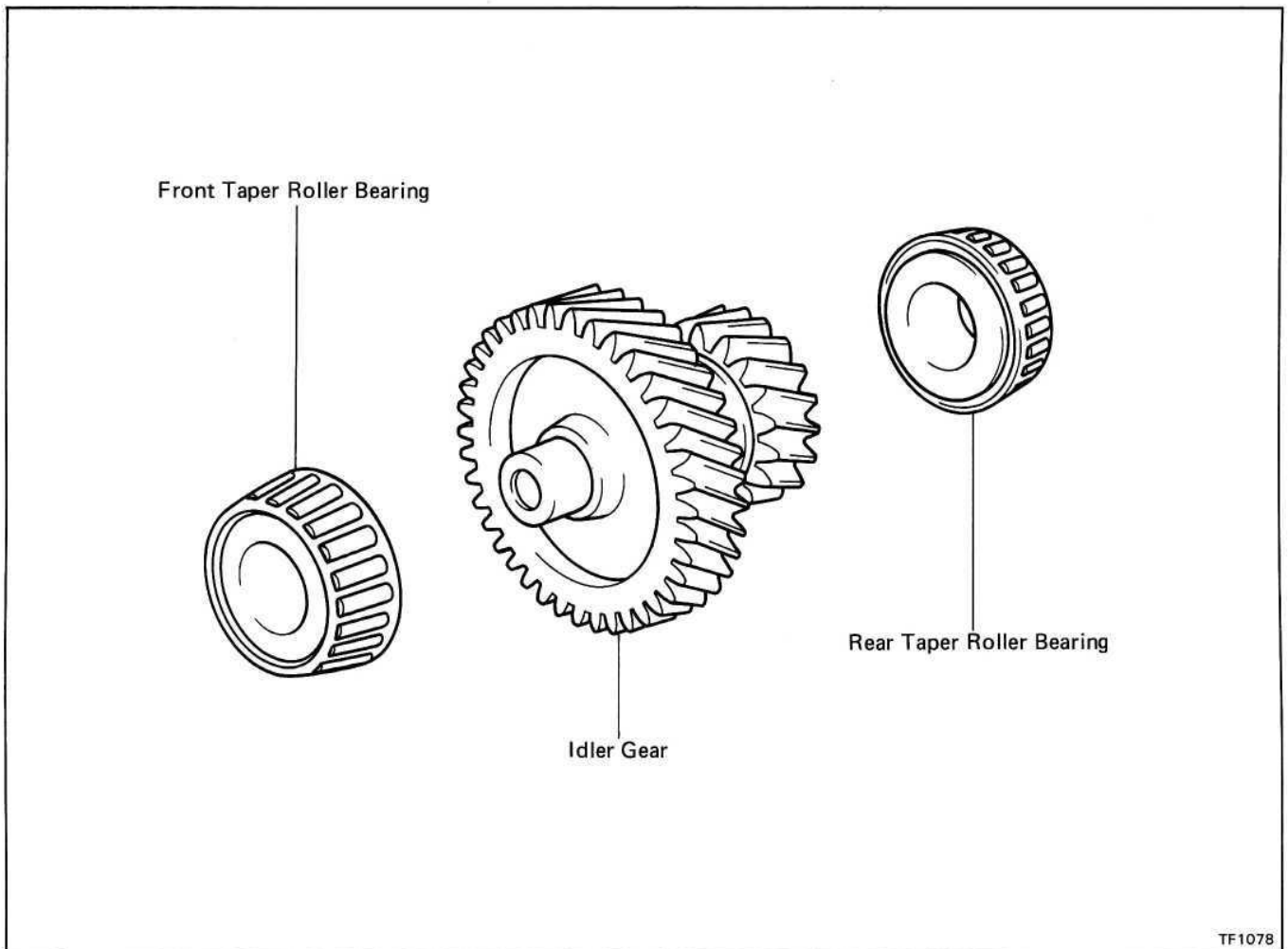

DISASSEMBLY OF IDLER GEAR ASSEMBLY

1. REMOVE FRONT TAPER ROLLER BEARING

Using SST, press and socket wrench, remove the front taper roller bearing.

SST 09555-55010

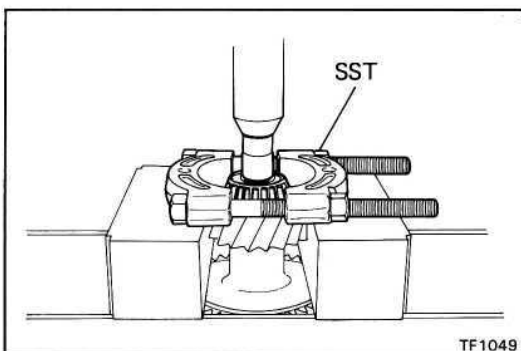

2. REMOVE REAR TAPER ROLLER BEARING

Using SST, press and socket wrench, remove the rear taper roller bearing.

SST 09950-00020

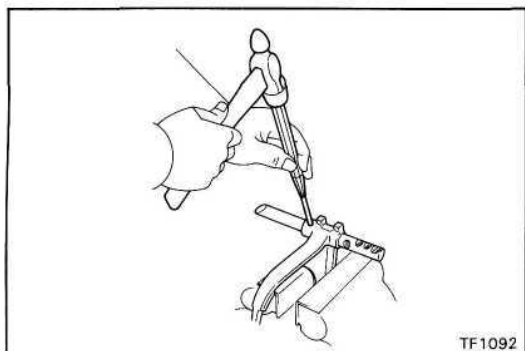

ASSEMBLY OF IDLER GEAR ASSEMBLY

1. INSTALL REAR TAPER ROLLER BEARING

Using SST and a press, install the rear taper roller bearing.

SST 09316-60010 (09316-00010, 09316-00070)

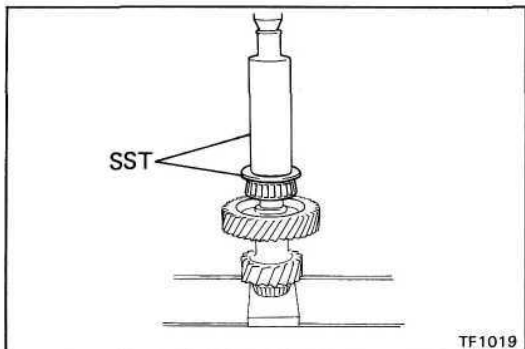

2. INSTALL FRONT TAPER ROLLER BEARING

Using SST and a press, install the front taper roller bearing.

SST 09316-60010 (09316-00010, 09316-00050)

Output Shaft Assembly COMPONENTS

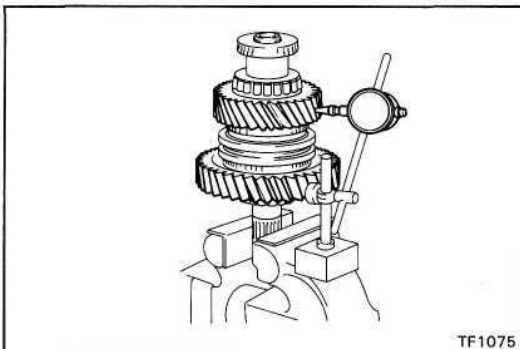
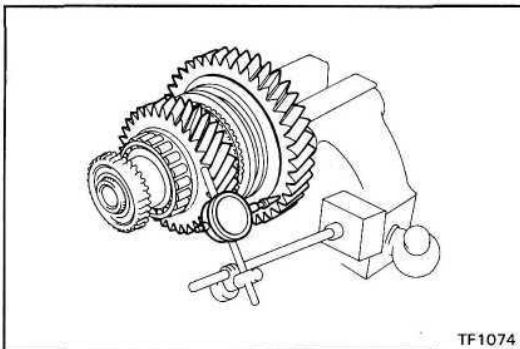
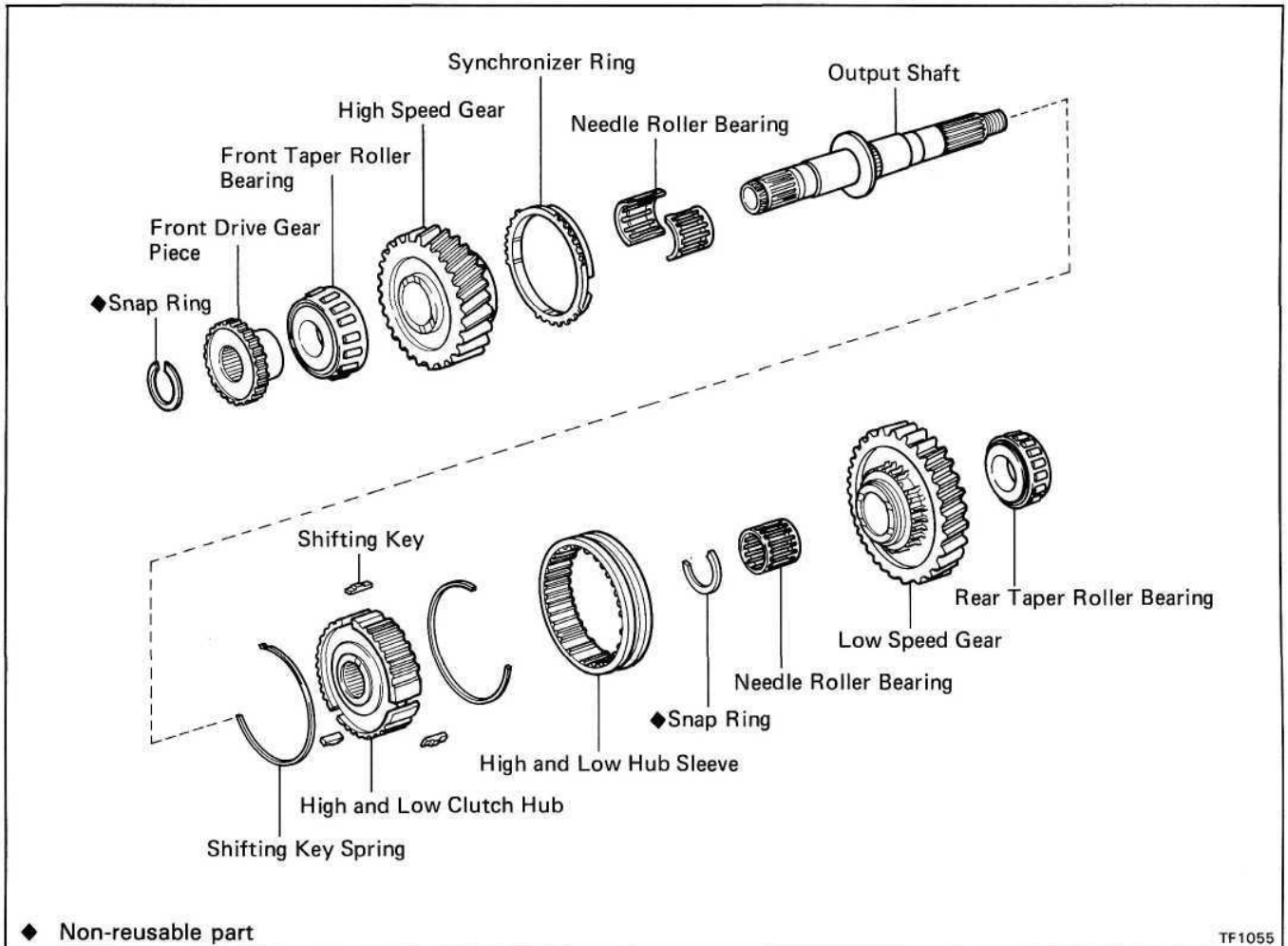

DISASSEMBLY OF OUTPUT SHAFT ASSEMBLY

1. MEASURE EACH GEAR THRUST CLEARANCE

Using a dial indicator, measure the thrust clearance of high speed gear and low speed gear.

High speed gear

Standard clearance: 0.28 — 0.43 mm
(0.0110 - 0.0169 in.)

Maximum clearance: 0.43 mm (0.0169 in.)

Low speed gear

Standard clearance: 0.20 — 0.45 mm
(0.0079 - 0.0177 in.)

Maximum clearance: 0.45 mm (0.0177 in.)

2. MEASURE EACH GEAR OIL CLEARANCE

Using a dial indicator, measure the oil clearance of high speed gear and low speed gear.

Standard clearance: 0.0075 - 0.034 mm
(0.0003 - 0.0013 in.)

Maximum clearance: 0.034 mm (0.0013 in.)

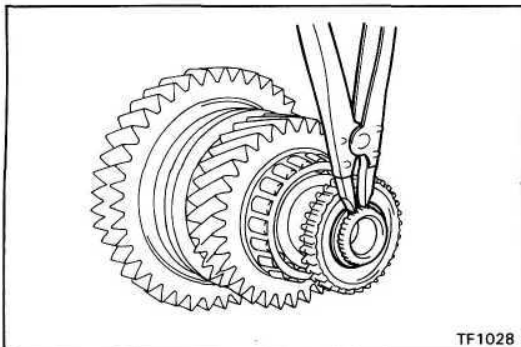

3. REMOVE FRONT DRIVE GEAR PIECE

(a) Using snap ring pliers, remove the snap ring.

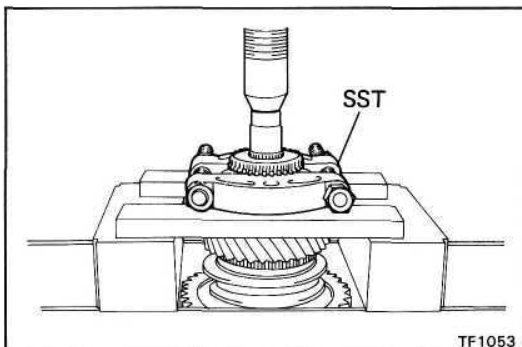

(b) Using SST and socket wrench, remove the front drive gear piece.

SST 09950-00020

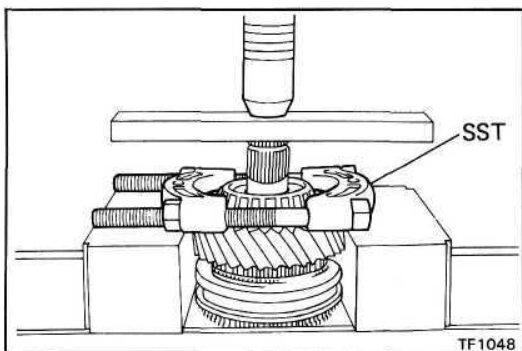

4. REMOVE FRONT TAPER ROLLER BEARING

Using SST and a press, remove the front taper roller bearing.

SST 09950-00020

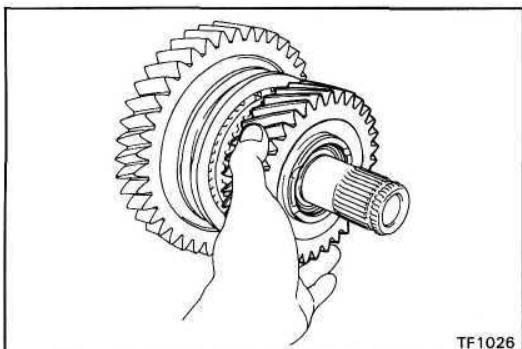

5. REMOVE HIGH SPEED GEAR, SYNCHRONIZER RING AND NEEDLE ROLLER BEARING

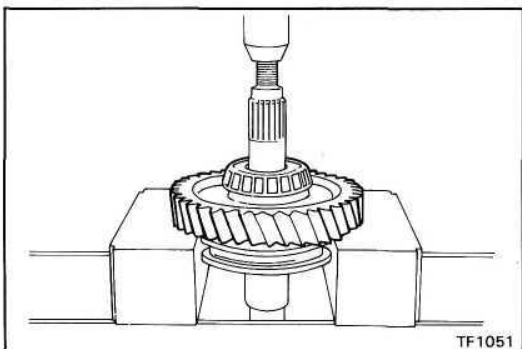

6. REMOVE LOW SPEED GEAR AND REAR TAPER ROLLER BEARING

(a) Using a press, remove the low speed gear and rear taper roller bearing.

(b) Remove the needle roller bearing.

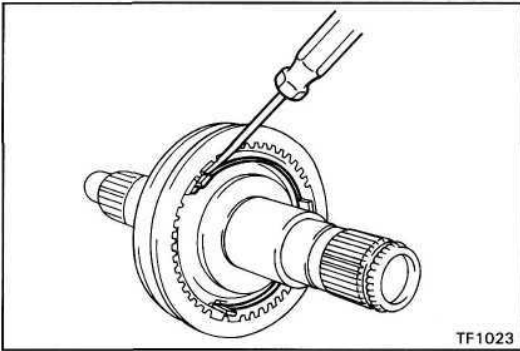
**7. REMOVE HIGH AND LOW HUB SLEEVE**

- (a) Using a screwdriver, remove the two springs.
- (b) Remove the high and low hub sleeve and shifting keys.

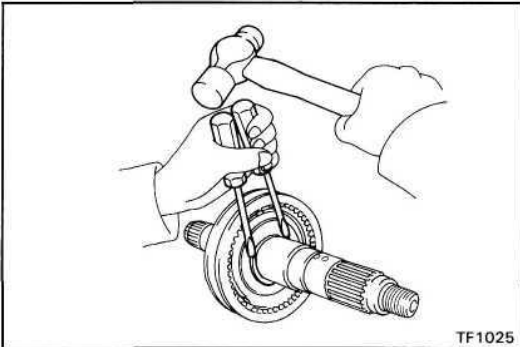

- (c) Using two screwdrivers and hammer, drive out the snap ring.

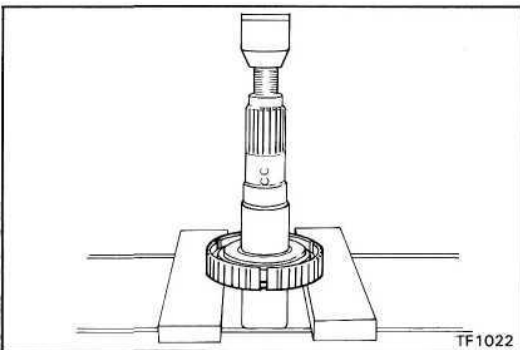

- (d) Using a press, remove the clutch hub.

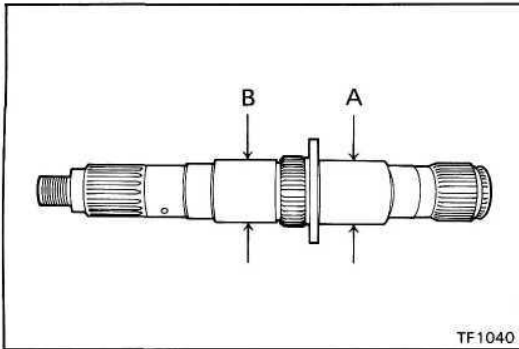

INSPECTION OF OUTPUT SHAFT ASSEMBLY

1. INSPECT OUTPUT SHAFT

- (a) Using a micrometer, measure the outer diameter of the output shaft journal.

Minimum diameter:

A: High speed gear 41.984 mm (1.6529 in.)

B: Low speed gear 42.984 mm (1.6923 in.)

If the clearance is less than the limit, replace the output shaft.

- (b) Using calipers, measure the output shaft journal length.

Maximum length:

A: High speed gear 46.55 mm (1.8327 in.)

B: Low speed gear 62.35 mm (2.4547 in.)

If the length is less than the limit, replace the output shaft.

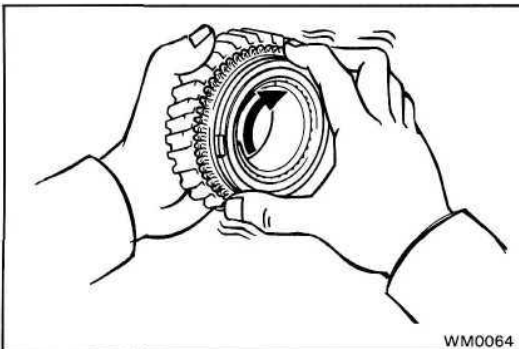
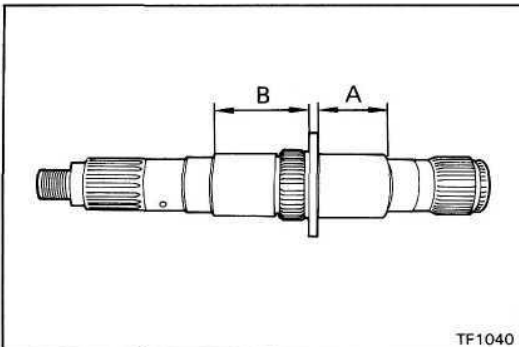

2. INSPECT SYNCHRONIZER RINGS

- (a) Turn the ring and push it in to check the braking action.

- (b) Measure the clearance between the synchronizer ring back and the gear spline end.

**Standard clearance: 0.75 — 1.65 mm
(0.0295 - 0.0650 in.)**

Minimum clearance: 0.75 mm (0.0295 in.)

If the clearance is less than the limit, replace the synchronizer ring.

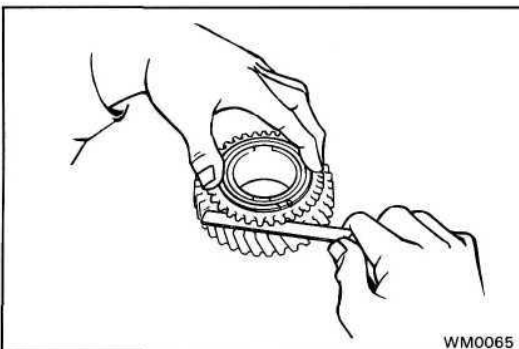

3. MEASURE CLEARANCE OF SHIFT FORK AND SLEEVE

Using a feeler gauge, measure the clearance between the hub sleeve and shift fork.

**Standard clearance: 0.1 — 0.4 mm
(0.0039 - 0.0157 in.)**

Maximum clearance: 0.4 mm (0.0157 in.)

If the clearance is more than the limit, replace the shift fork or hub sleeve.

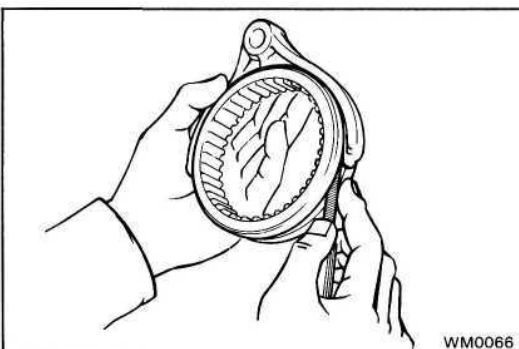

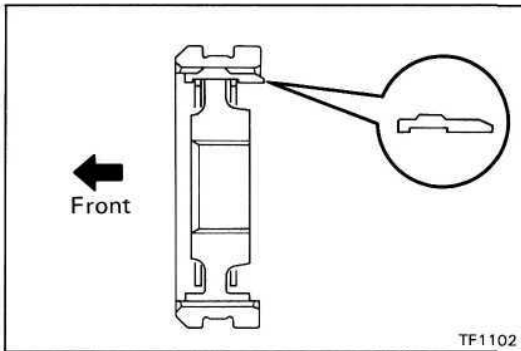

ASSEMBLY OF OUTPUT SHAFT ASSEMBLY

1. INSERT CLUTCH HUB INTO HIGH AND LOW HUB SLEEVE

- (a) Insert the clutch hub and shifting keys to the high and low hub sleeve.
- (b) Install the shifting key springs under the shifting keys.

NOTICE: Install the key springs positioned so that their end gaps are not in line.

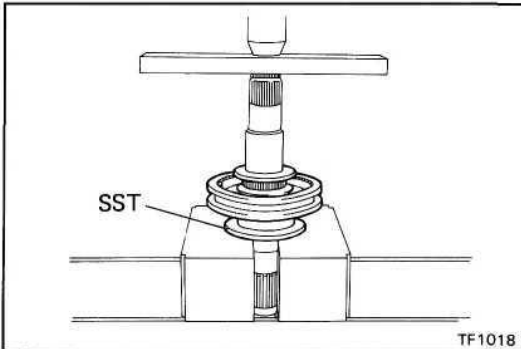

2. INSTALL HIGH AND LOW HUB SLEEVE

- (a) Using SST and a press, install the high and low hub sleeve.

SST 09316-20011

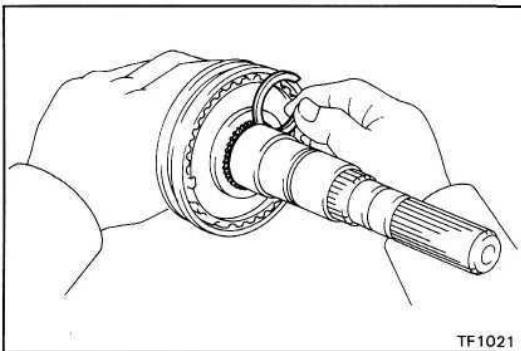

- (b) Select a snap ring that will allow minimum axial play and install it on the shaft.

| Mark | Thickness mm (in.) |
|------|--------------------|
| A | 2.60 (0.1024) |
| B | 2.65 (0.1043) |
| C | 2.70 (0.1063) |
| D | 2.75 (0.1083) |
| E | 2.80 (0.1102) |
| F | 2.85 (0.1122) |
| G | 2.90 (0.1142) |

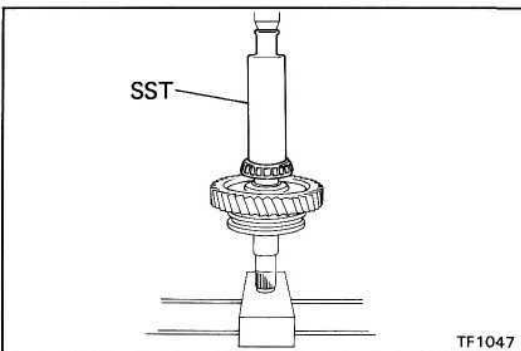

3. INSTALL NEEDLE ROLLER BEARING, LOW SPEED GEAR AND REAR TAPER ROLLER BEARING

- (a) Apply gear oil to the needle roller bearing.
- (b) Install the needle roller bearing and low speed gear.
- (c) Using SST and a press, install the rear taper roller bearing.

SST 09316-60010 (09316-00010)

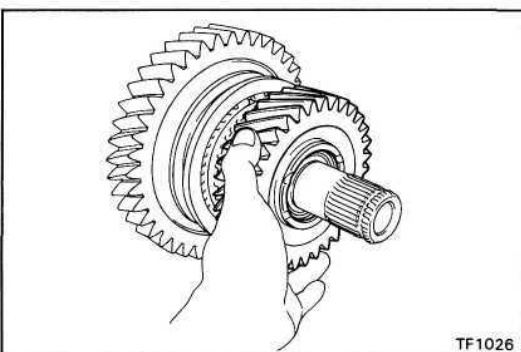

4. INSTALL HIGH SPEED GEAR, SYNCHRONIZER RING AND NEEDLE ROLLER BEARING

- (a) Apply gear oil to the needle roller bearing.
- (b) Install high speed gear, synchronizer ring and needle roller bearing.

NOTICE: Align the ring slots with the shifting keys.

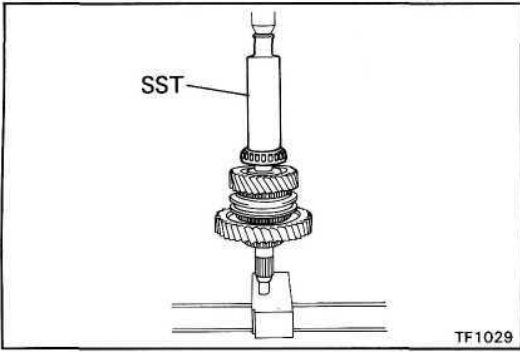

5. INSTALL FRONT TAPER ROLLER BEARING

Using SST and a press, install the front taper roller bearing.

SST 09316-60010 (09316-00010)

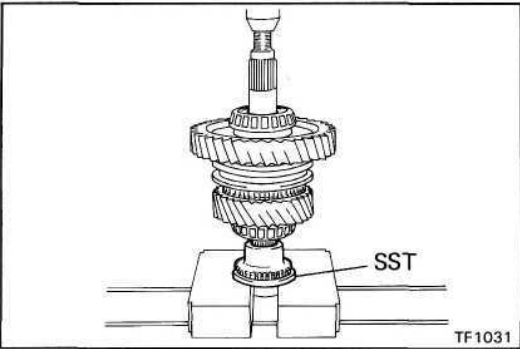

6. INSTALL FRONT DRIVE GEAR PIECE

(a) Using SST and a press, install the front drive gear piece.

SST 09316-60010 (09316-00030)

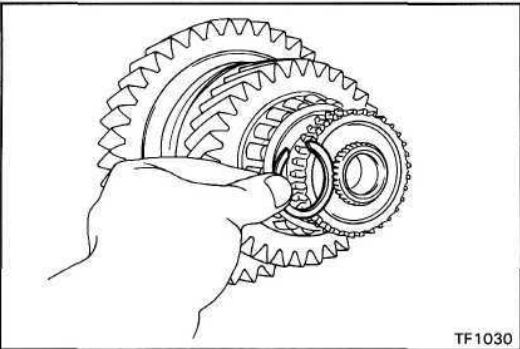

(b) Select a snap ring that will allow minimum axial play.

| Mark | Thickness mm (in.) |
|------|--------------------|
| A | 2.0 (0.0787) |
| B | 2.1 (0.0827) |
| C | 2.2 (0.0866) |
| D | 2.3 (0.0906) |
| E | 2.4 (0.0945) |

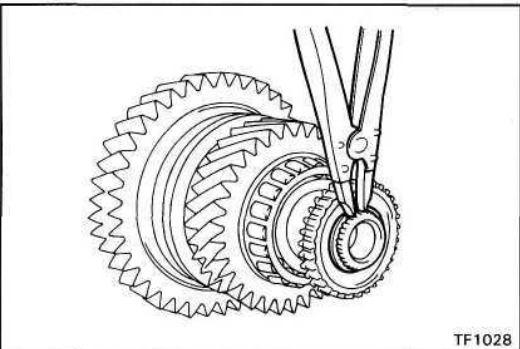

(c) Using snap ring pliers, install the snap ring.

Front Extension Housing Assembly COMPONENTS

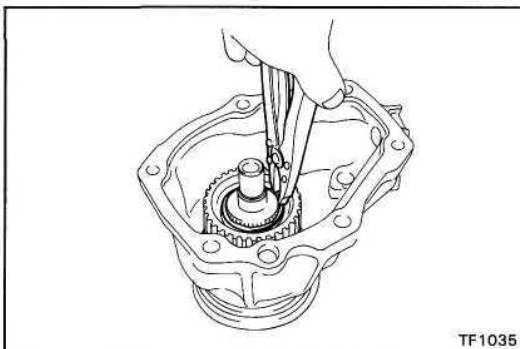
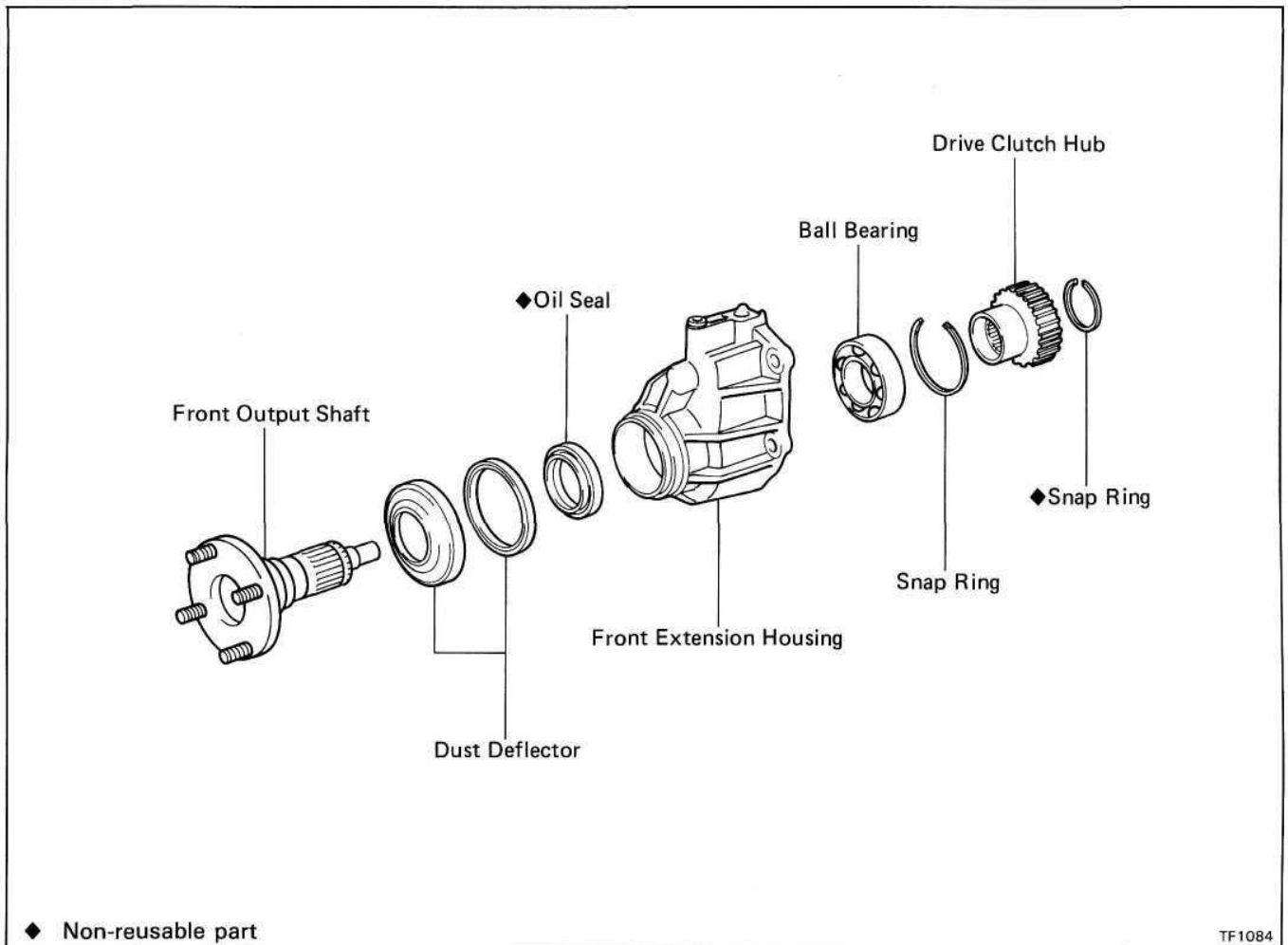

DISASSEMBLY OF FRONT EXTENSION HOUSING ASSEMBLY

1. REMOVE DRIVE CLUTCH HUB

(a) Using snap ring pliers, remove the snap ring.

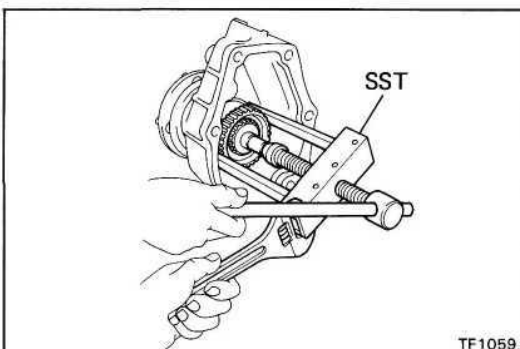

(b) Using SST, remove the drive clutch hub.
SST 09213-27010

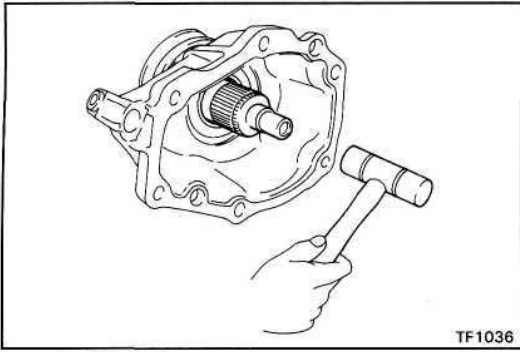
**2. REMOVE FRONT OUTPUT SHAFT**

Using a plastic hammer, tap the front output shaft and remove it.

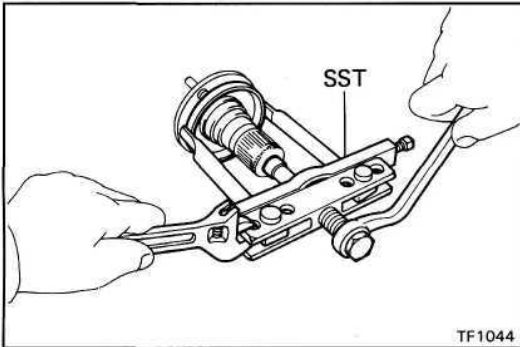
**3. REMOVE DUST DEFLECTORS**

(a) Using SST, remove the dust deflector.
SST 09950-20017

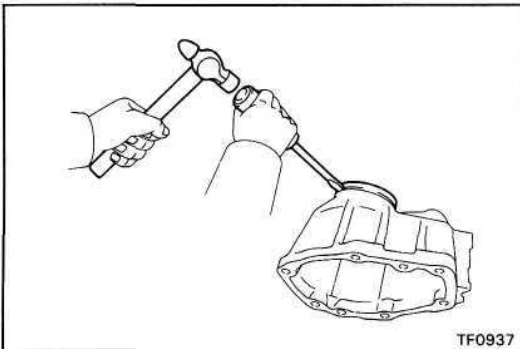

(b) Using a screwdriver and hammer, tap the dust deflector and remove it.

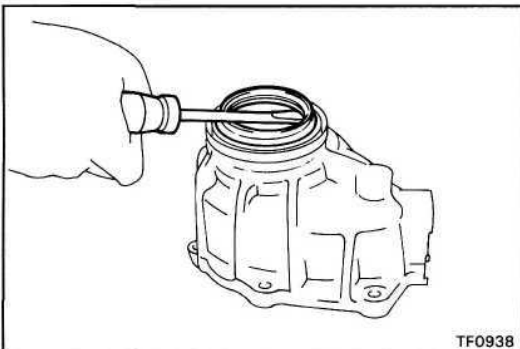
**4. REMOVE OIL SEAL**

Using a screwdriver, pry out the oil seal.

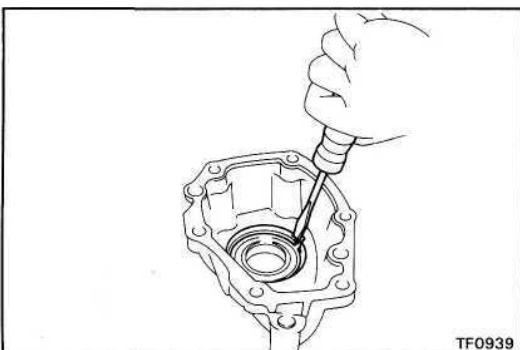
**5. REMOVE BALL BEARING**

(a) Using a screwdriver, remove the snap ring.

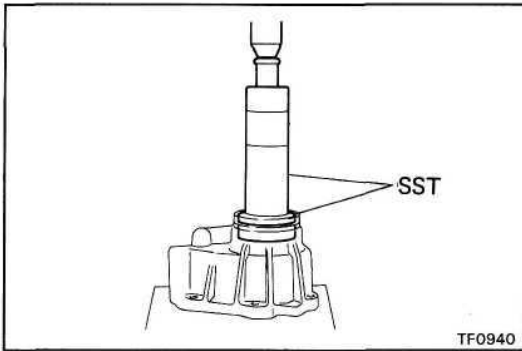

(b) Using SST and a press, remove the ball bearing.
SST 09316-60010 (09316-00010, 09316-00070)

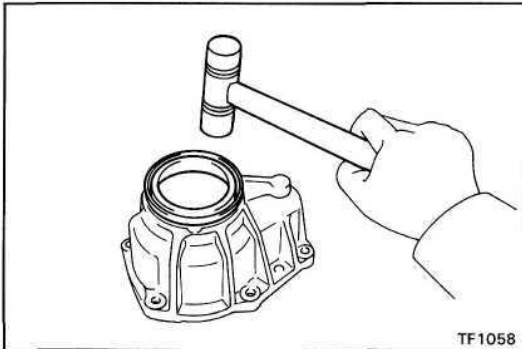

ASSEMBLY OF FRONT EXTENSION HOUSING ASSEMBLY

1. INSTALL DUST DEFLECTORS

(a) Using a plastic hammer, install the dust deflector.

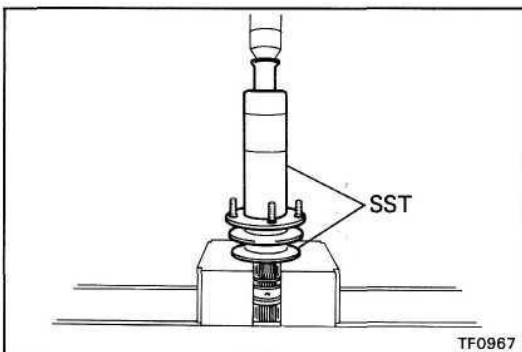

(b) Using SST and a press, install the dust deflector.
SST 09316-20011, 09316-60010(09316-00010)

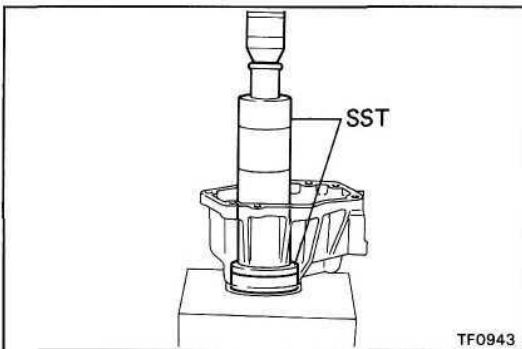

2. INSTALL BALL BEARING

(a) Using SST and a press, install the ball bearing.
SST 09316-60010 (09316-00010, 09316-00030)

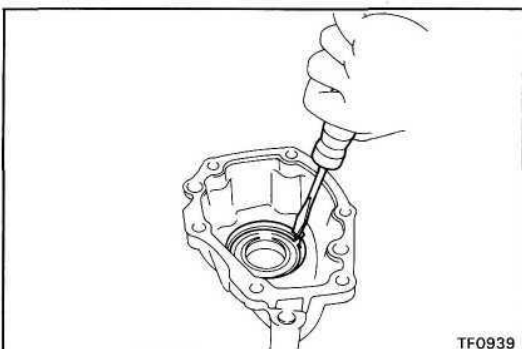

(b) Select a snap ring that will allow minimum axial play and install it.

| Mark | Thickness mm (in.) |
|------|--------------------|
| A | 1.7 (0.0669) |
| B | 1.8 (0.0709) |

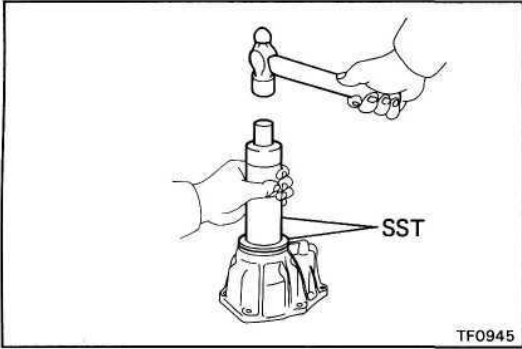

3. INSTALL OIL SEAL

Using SST and a hammer, drive in a new oil seal.
 SST 09316-60010 (09316-00010, 09316-00060)

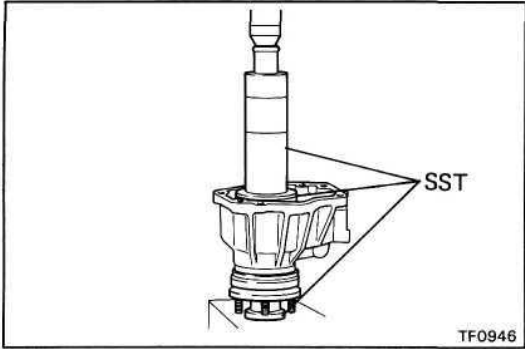

4. INSTALL FRONT OUTPUT SHAFT AND DRIVE CLUTCH HUB

(a) Using SST and a press, install the front output shaft and drive clutch hub.

SST 09316-20011, 09316-60010
 (09316-00010, 09316-00040, 09316-00070)

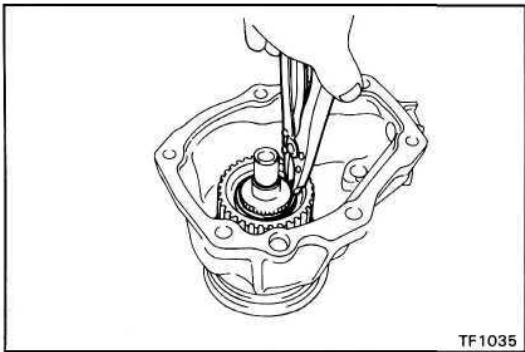

(b) Select a snap ring that will allow minimum axial play and install it.

| Mark | Thickness mm (in.) |
|------|--------------------|
| A | 1.8 (0.0709) |
| B | 1.9 (0.0748) |
| C | 2.0 (0.0787) |
| D | 2.1 (0.0827) |
| E | 2.2 (0.0866) |

Rear Extension Housing Assembly COMPONENTS

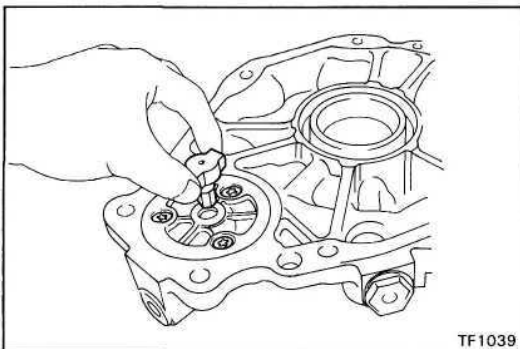
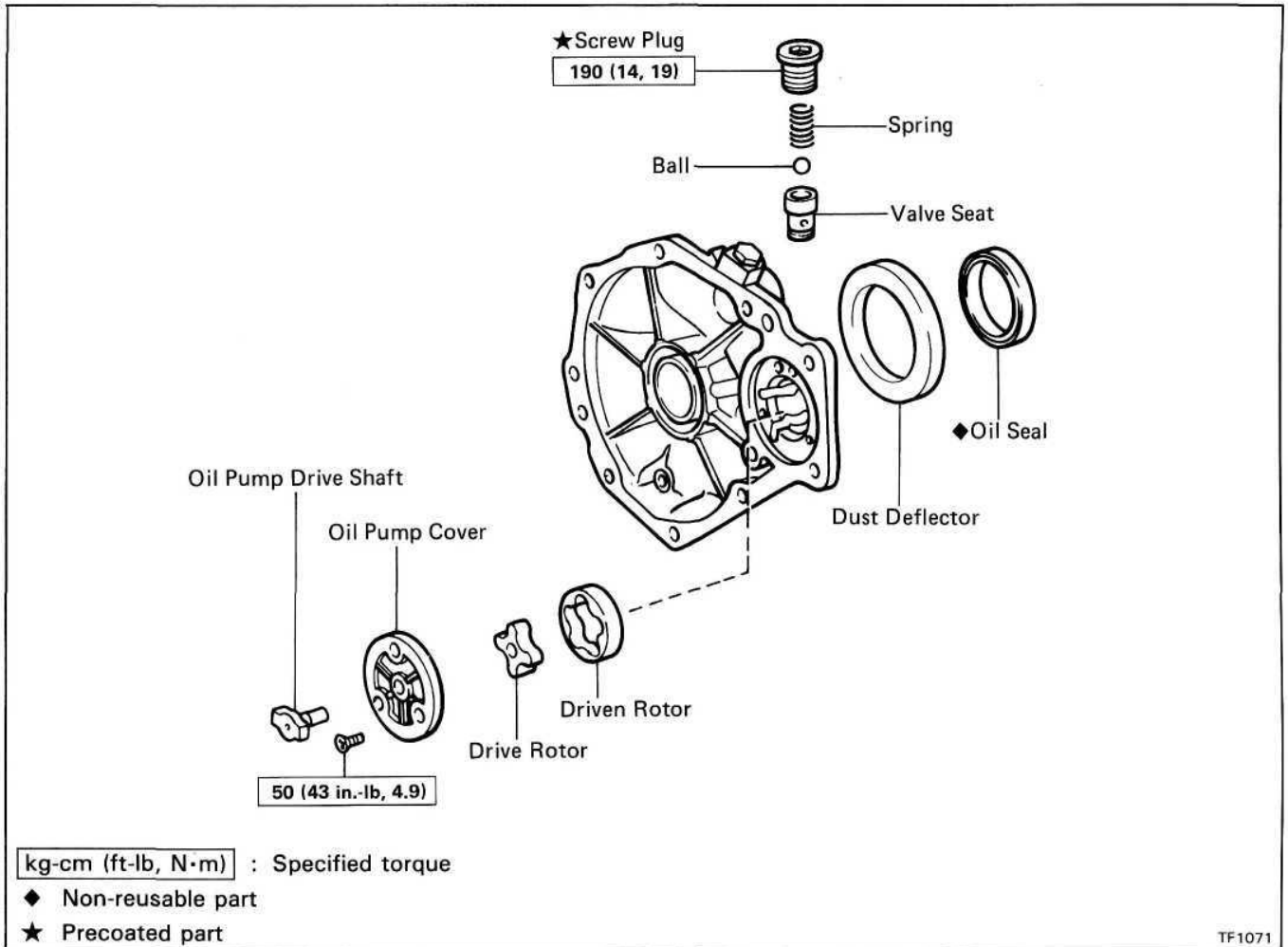

DISASSEMBLY OF REAR EXTENSION HOUSING ASSEMBLY

1. REMOVE OIL PUMP DRIVE SHAFT

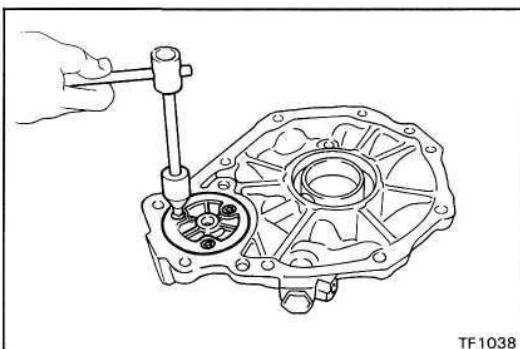

2. REMOVE OIL PUMP COVER

Using a torx socket wrench, remove the three screws and oil pump cover.

(Torx socket wrench T30 09042-00010)

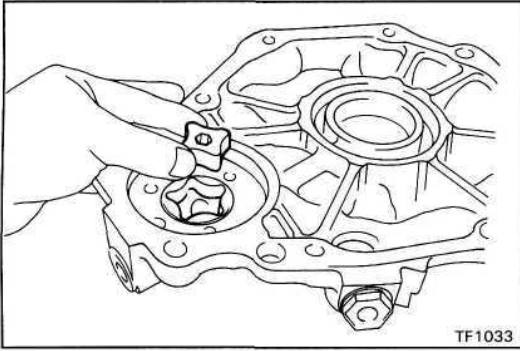
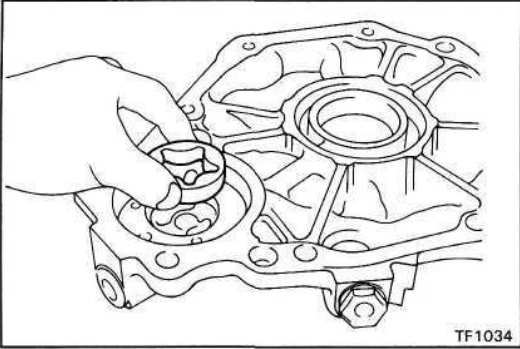
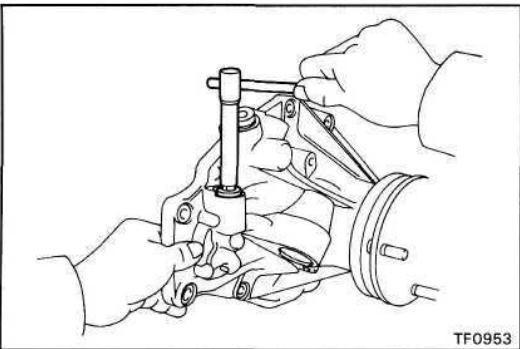
**3. REMOVE DRIVE ROTOR****4. REMOVE DRIVEN ROTOR****5. REMOVE SCREW PLUG, SPRING, BALL AND VALVE SEAT**

(a) Using a hexagon wrench, remove the screw plug.

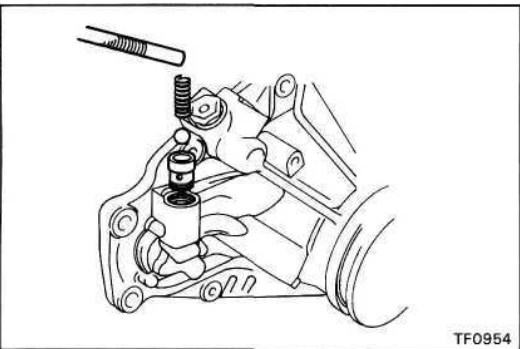

(b) Using a magnetic finger, remove the spring, ball and valve seat.

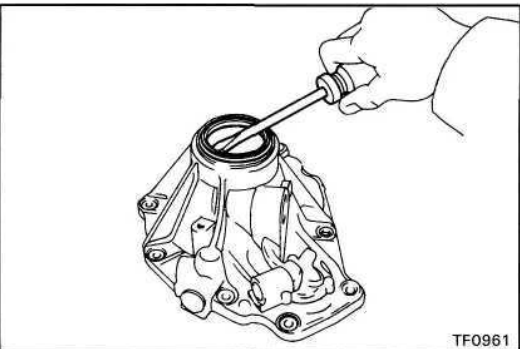
**6. REMOVE OIL SEAL**

Using a screwdriver, pry out the oil seal.

ASSEMBLY OF REAR EXTENSION HOUSING ASSEMBLY

1. INSTALL DUST DEFLECTORS

Using SST and a hammer, install the dust deflector.
SST 09316-60010 (09316-00010, 09316-00040)

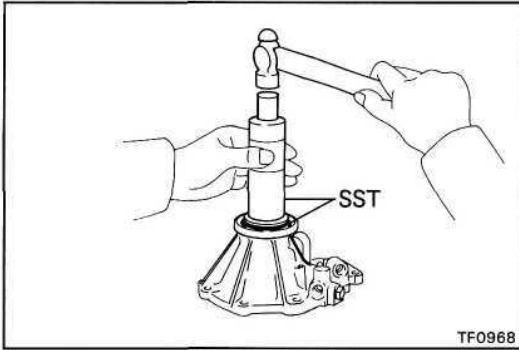

2. INSTALL VALVE SEAT, BALL, SPRING AND SCREW PLUG

- (a) Apply gear oil to the ball.
- (b) Install the valve seat, ball and spring.

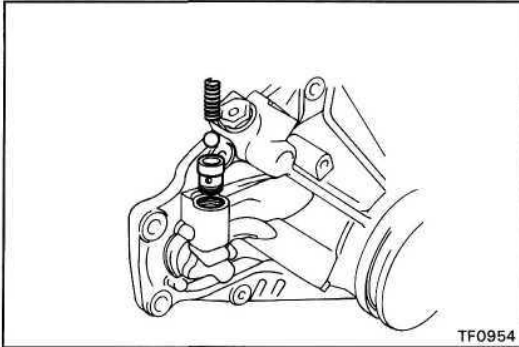

- (c) Install and torque the screw plug.
Torque: 190 kg-cm (14 ft-lb, 19 Nm)

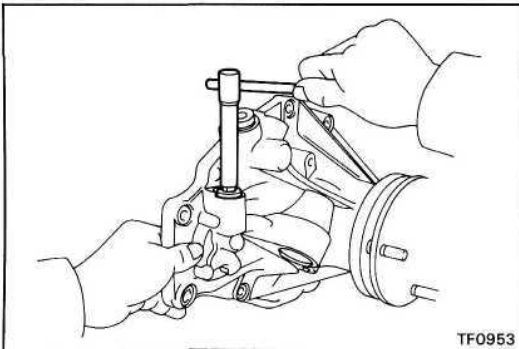

3. INSTALL DRIVEN ROTOR

- (a) Apply gear oil to the driven rotor.
- (b) Install the driven rotor.

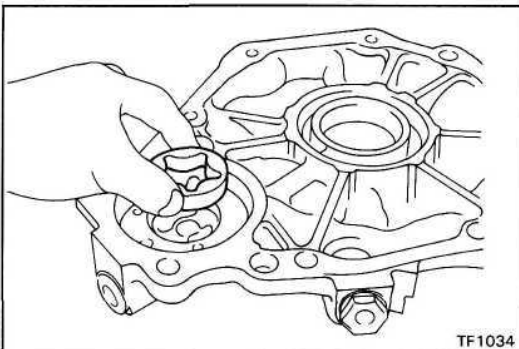

4. INSTALL DRIVE ROTOR

- (a) Apply gear oil to the drive rotor.
- (b) Install the drive rotor.

HINT: Align the alignment marks.

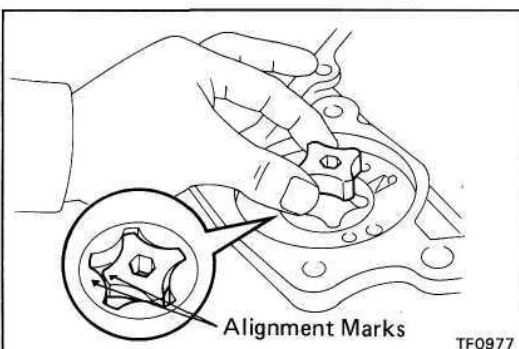

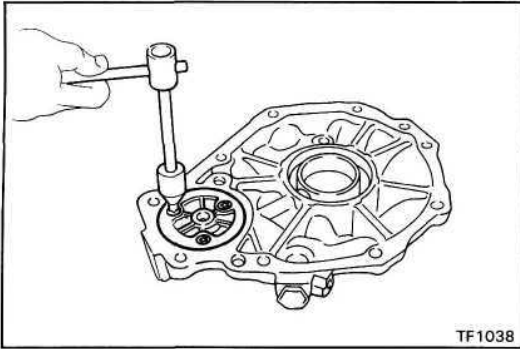
**5. INSTALL OIL PUMP COVER**

- (a) Install the oil pump cover.
- (b) Install and torque the three bolts.
(Torx socket wrench T30 09042-00010)

Torque: 50 kg-cm (43 in.-lb, 4.9 Nm)

ASSEMBLY OF TRANSFER

1. INSTALL TWO BEARING RACES TO FRONT CASE

- (a) Using SST and a hammer, install the output shaft bearing race.

SST 09316-20011, 09316-60010 (09316-00010, 09316-00030)

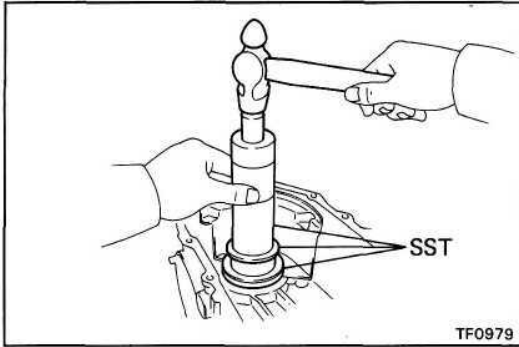

- (b) Using SST and a hammer, install the idle gear bearing race.

SST 09316-60010 (09316-00010, 09316-00040)

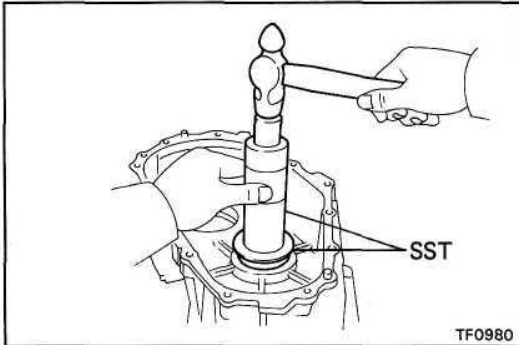

2. INSTALL OIL RECEIVER TO FRONT CASE

- (a) Install the oil receiver.
 (b) Install and torque the bolt.

Torque: 55 kg-cm (48 in.-lb, 5.4 N-m)

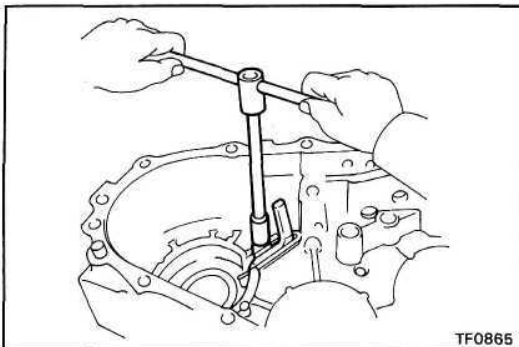

3. INSTALL SHIFT OUTER LEVER AND INNER LEVER

- (a) Install the shift outer lever and inner lever.

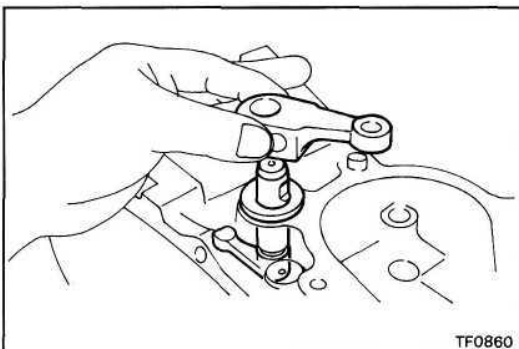

- (b) Using a pin punch and a hammer, tap in the lever lock pin.

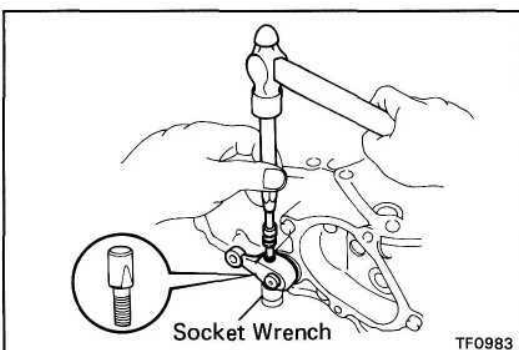

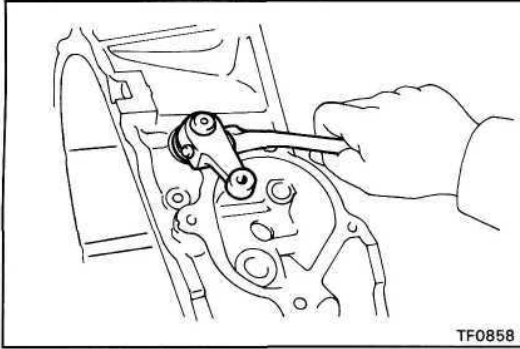

(c) Install the washer and nut.

Torque: 120 kg-cm (9 ft-lb, 12 Nm)

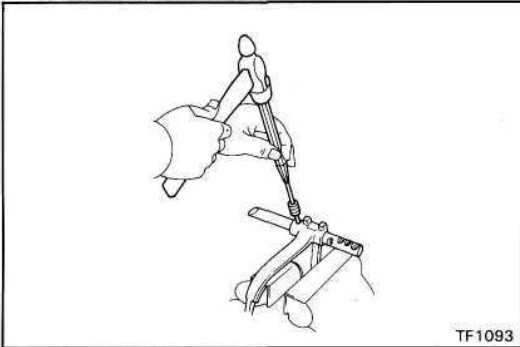

4. ASSEMBLE SHIFT FORK NO.1 AND FORK SHAFT

Using a pin punch and a hammer, drive in the slotted spring pin.

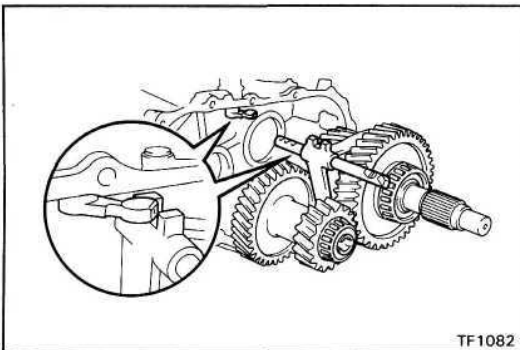

5. INSTALL IDLE GEAR ASSEMBLY, OUTPUT SHAFT ASSEMBLY, SHIFT FORK NO.1 AND FORK SHAFT

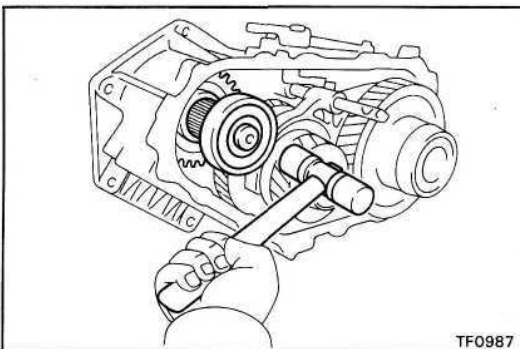

6. INSTALL INPUT SHAFT ASSEMBLY

Using a plastic hammer, tap in the input shaft.

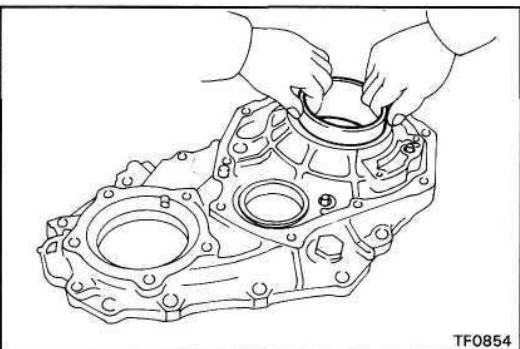

7. INSTALL TWO BEARING RACES FROM REAR CASE

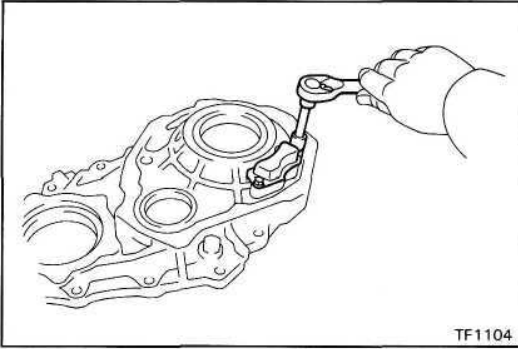
**8. INSTALL OIL STRAINER TO REAR CASE**

- (a) Install the oil strainer.
- (b) Install and torque the bolts.

Torque: 50 kg-cm (43 in.-lb, 4.9 Nm)

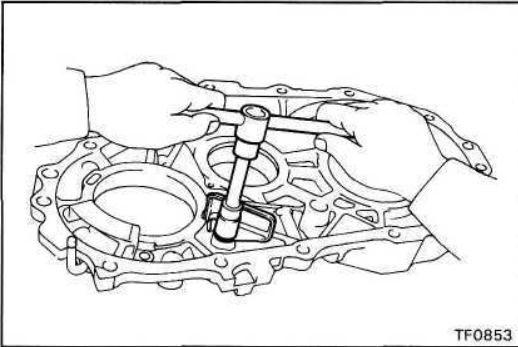
**9. INSTALL OIL RECEIVER**

Install the oil receiver with bolt.

Torque: 130 kg-cm (9 ft-lb, 13 Nm)

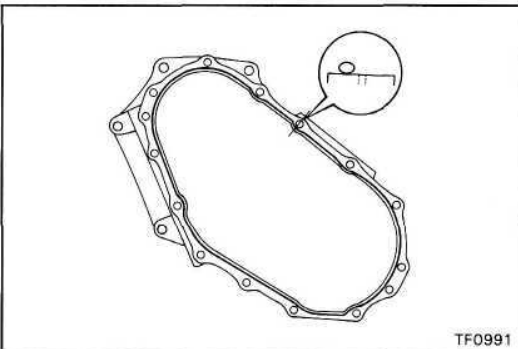
**10. ASSEMBLE FRONT CASE AND REAR CASE**

- (a) Apply seal packing to the front case as shown.

Seal packing: Part No.08826-00090, THREE BOND 1281 or equivalent

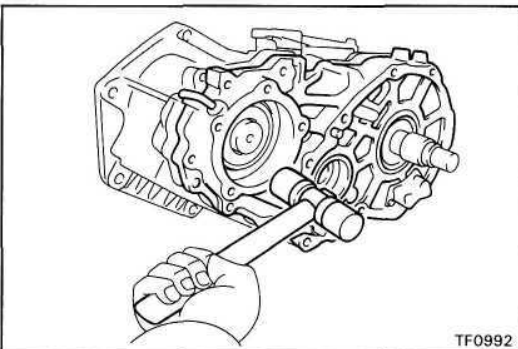

- (b) Using a plastic hammer, tap the rear case and assemble it.

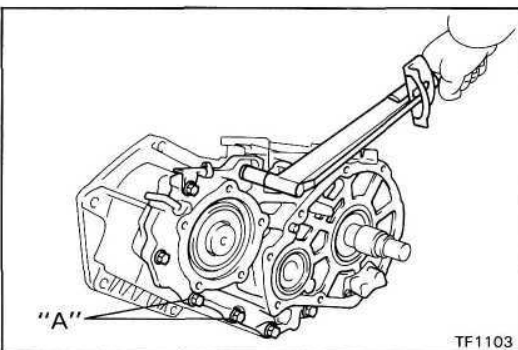

- (c) Apply liquid sealer to the "A" bolt threads.

Sealant: Part No.08833-00080, THREE BOND 1344, LOCTITE 242 or equivalent

- (d) Install and torque the eight bolts.

Torque: 380 kg-cm (27 ft-lb, 37 Nm)

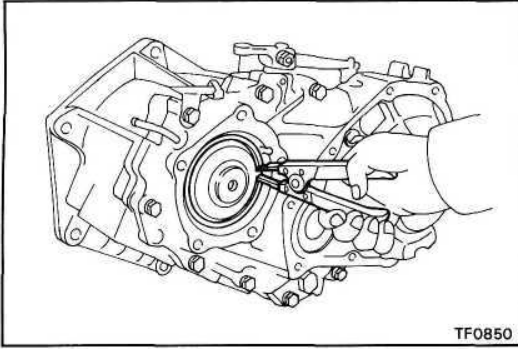

- (e) Using snap ring pliers, install the snap ring.

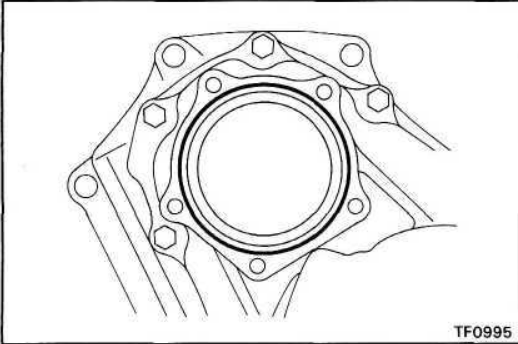

11. INSTALL CASE COVER

- (a) Apply seal packing to the rear case as shown.

Seal packing: Part No.08826-00090, THREE BOND 1281 or equivalent

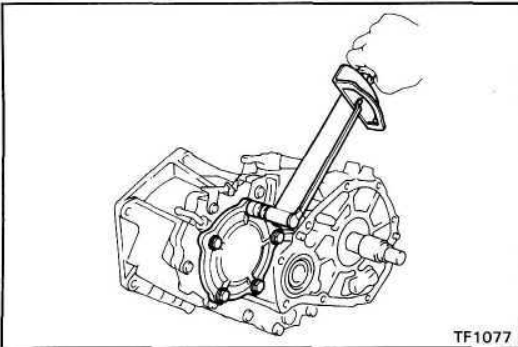

- (b) Install the case cover.

- (c) Install and torque the five bolts.

Torque: 380 kg-cm (27 ft-lb, 37 Nm)

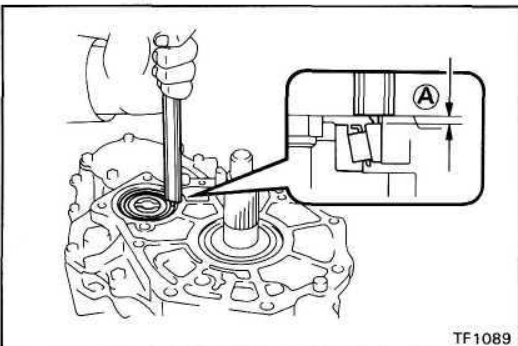

12. SELECT ADJUSTING SHIMS FOR IDLER GEAR

- (a) Using a vernier caliper with depth gauge, measure dimension **A**.

HINT: Lightly hold down the bearing outer race in the thrust direction to eliminate any looseness before making the measurement.

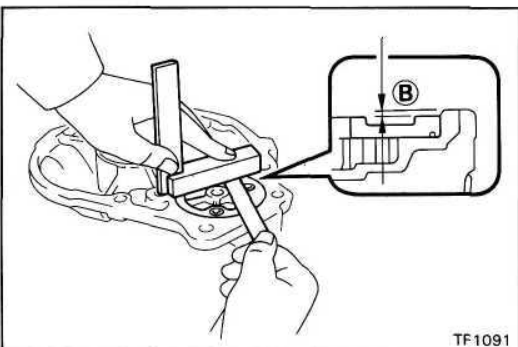

- (b) Using a steel straight edge and feeler gauge, measure the clearance of dimension **B**.

- (c) Calculate the required thickness of the adjusting shim.

Thickness: Dimension **A + Dimension **B** + **C****

© 0.02 - 0.07 mm (0.0008 - 0.0028 in.)

- (d) From the following table, select a shim with a thickness fitting within the range of the calculation in (c).

| Mark | Thickness mm (in.) | Mark | Thickness mm (in.) |
|------|--------------------|------|--------------------|
| A | 0.15 (0.0059) | G | 3.00 (0.1181) |
| B | 0.30 (0.0118) | H | 3.20 (0.1260) |
| C | 0.45 (0.0177) | J | 3.40 (0.1339) |
| D | 2.40 (0.0945) | K | 3.60 (0.1417) |
| E | 2.60 (0.1024) | L | 3.80 (0.1496) |
| F | 2.80 (0.1102) | M | 4.00 (0.1575) |

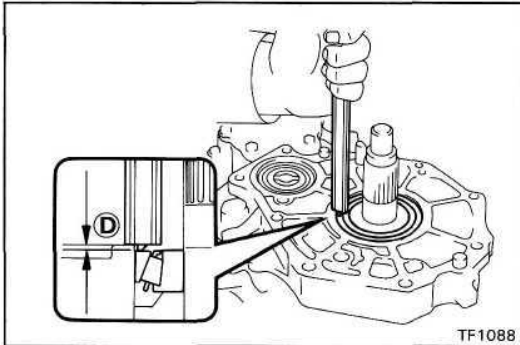

13. SELECT ADJUSTING SHIMS FOR OUTPUT SHAFT TAPER ROLLER BEARING

- (a) Using a vernier caliper with depth gauge, measure dimension \textcircled{D} .

HINT: Lightly hold down the bearing outer race in the thrust direction to eliminate any looseness before making the measurement.

Thickness: Dimension \textcircled{D} + \textcircled{E}

\textcircled{E} 0.04 - 0.09 mm (0.0016 - 0.0035 in.)

- (b) From the following table, select a shim with a thickness fitting within the range of the calculation in (a).

| Mark | Thickness mm (in.) | Mark | Thickness mm (in.) |
|------|--------------------|------|--------------------|
| A | 0.15 (0.0059) | G | 1.60 (0.0630) |
| B | 0.30 (0.0118) | H | 1.80 (0.0709) |
| C | 0.45 (0.0177) | J | 2.00 (0.0787) |
| D | 1.00 (0.0394) | K | 2.20 (0.0866) |
| E | 1.20 (0.0472) | L | 2.40 (0.0945) |
| F | 1.40 (0.0551) | M | 2.60 (0.1024) |

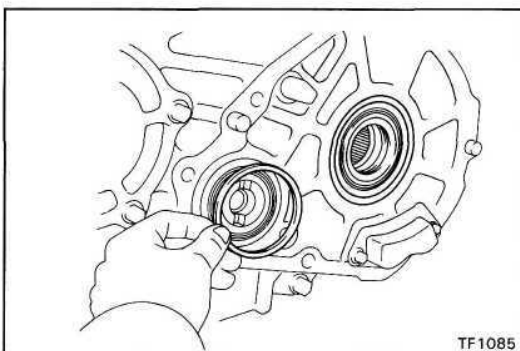

14. INSTALL SHIMS

Apply MP grease to the reuse shims.

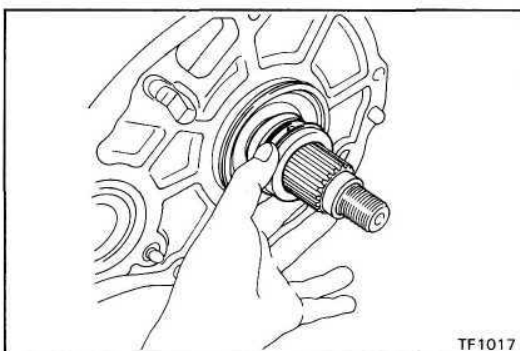

15. INSTALL BALL AND SPACER NO.1

- (a) Apply MP grease to the ball.
 (b) Install the ball and spacer No.1.

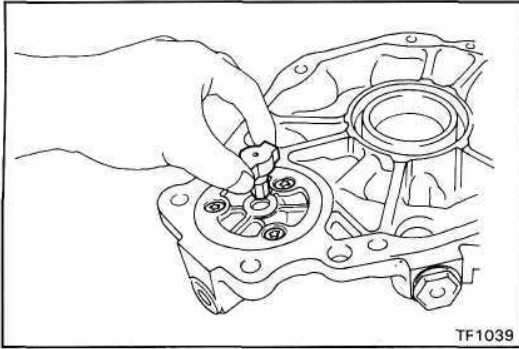

16. INSTALL REAR EXTENSION HOUSING

- (a) Install the oil pump drive shaft.

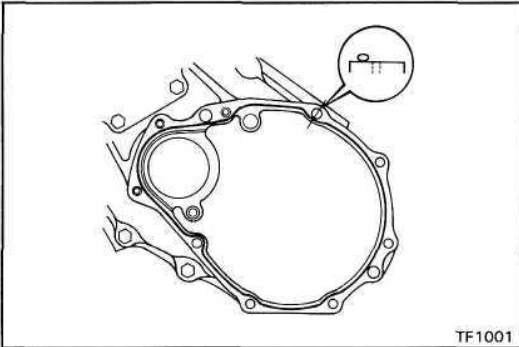

- (b) Apply seal packing to the rear case as shown.

Seal packing: Part No.08826-00090, THREE BOND 1281 or equivalent

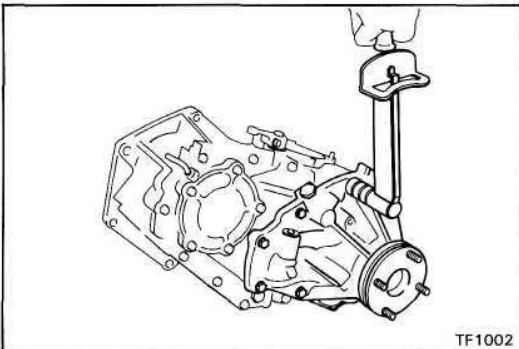

- (c) Install rear extension housing.

- (d) Install and torque the eight bolts.

Torque: 380 kg-cm (27 ft-lb, 37 Nm)

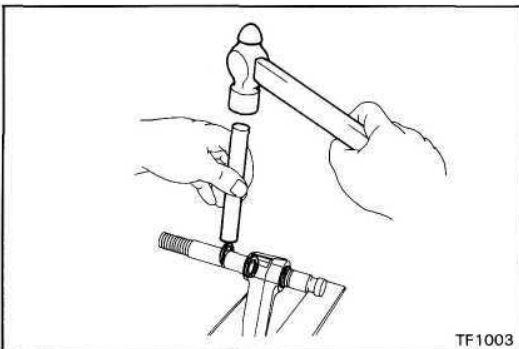

17. ASSEMBLE SHIFT FORK NO.2 AND FORK SHAFT

(Motor shift type)

- (a) Assemble the shift fork No.2 and fork shaft.

- (b) Using a brass bar and hammer, tap in the snap ring.

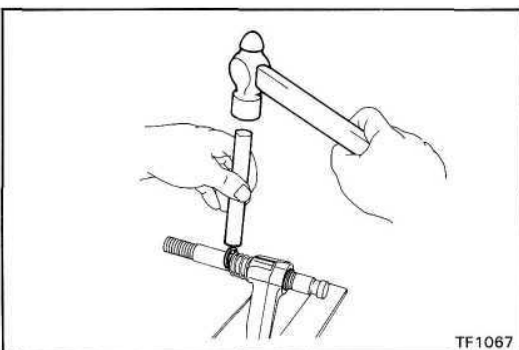

(Direct shift type)

- (a) Assemble the shift fork No.2, fork shaft and spring.

- (b) Using a brass bar and hammer, tap in the snap ring.

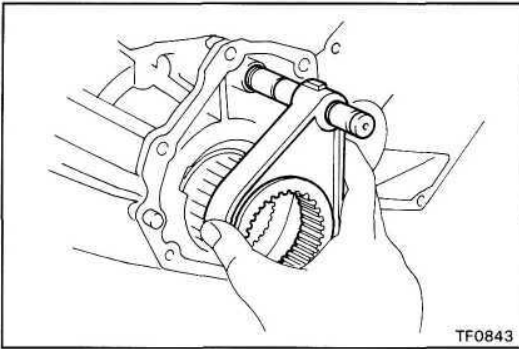

18. INSTALL CLUTCH SLEEVE, SHIFT FORK NO.2 AND FORK SHAFT

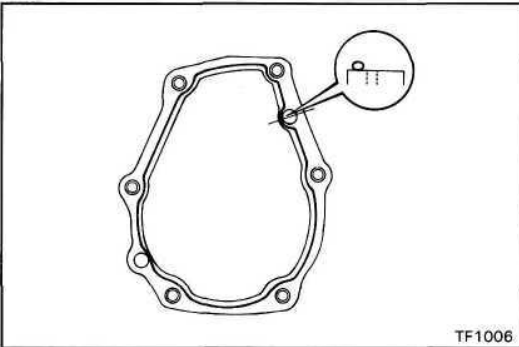

19. INSTALL FRONT EXTENSION HOUSING

- (a) Remove any packing material and be careful not to drop oil on the contacting surfaces of the front case.
- (b) Apply seal packing to the front case as shown.

Seal packing: Part No.08826-00090, THREE BOND 1281 or equivalent

HINT: Install the front extension housing as soon as the seal packing is applied.

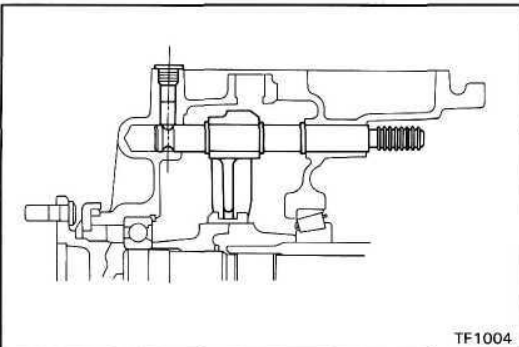

- (c) Set the clutch sleeve in 4WD condition, install the front extension housing.

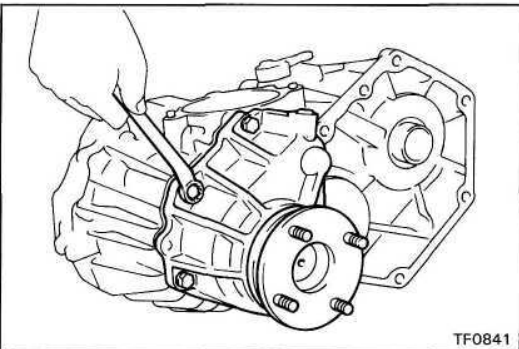

- (d) Install and torque the six bolts.

Torque: 380 kg-cm (27 ft-lb, 37 Nm)

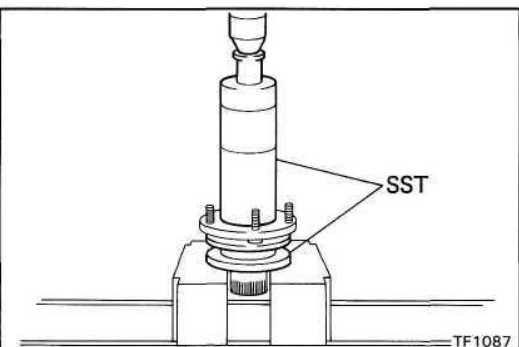

20. INSTALL DUST DEFLECTOR

Using SST and a press, install the dust deflector.

SST 0931 6-20011, 09316-60010 (09316-00010)

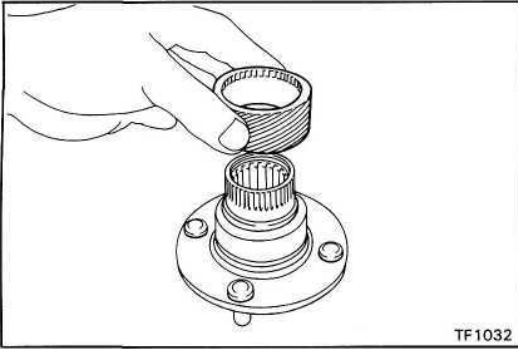

21. INSTALL OUTPUT SHAFT COMPANION FLANGE

- (a) Install the speedometer drive gear to the output shaft companion flange.

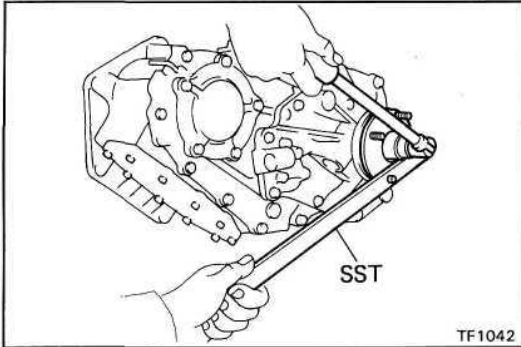

- (b) Install the output shaft companion flange.

- (c) Install and torque the nut.

Torque: 1,300 kg-cm (94 ft-lb, 128 Nm)

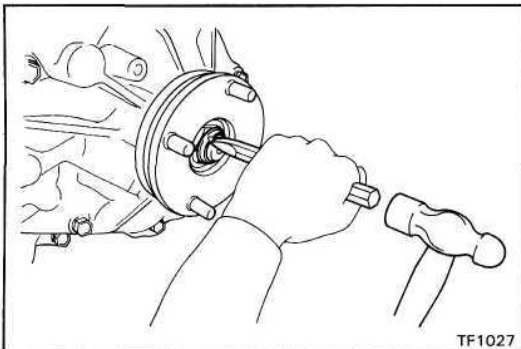

- (d) Stake the nut.

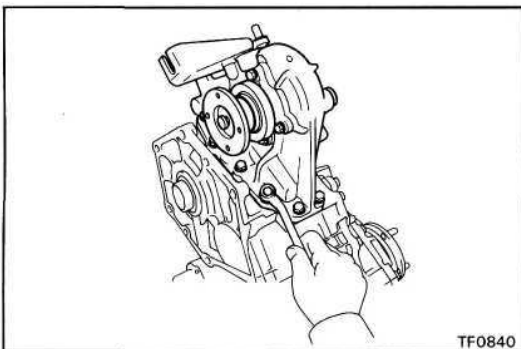

22. (w/ POWER TAKE-OFF) INSTALL POWER TAKE-OFF CASE

- (a) Install the power take-off case and a new gasket.

- (b) Apply liquid sealer to the bolt threads.

Sealant: Part No.08833-00080, THREE BOND 1344, LOCTITE 242 or equivalent

- (c) Install and torque the ten bolts.

Torque: 195 kg-cm (14 ft-lb, 19 Nm)

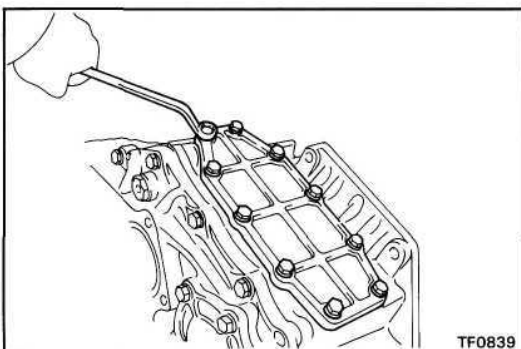

23. (w/o POWER TAKE-OFF) INSTALL POWER TAKE-OFF COVER

- (a) Install the power take-off cover and a new gasket.

- (b) Apply liquid sealer to the bolt threads.

Sealant: Part No.08833-00080, THREE BOND 1344, LOCTITE 242 or equivalent

- (c) Install and torque the ten bolts.

Torque: 195 kg-cm (14 ft-lb, 19 Nm)

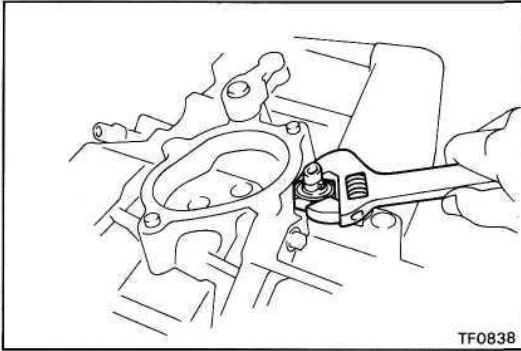
**24. INSTALL 4WD INDICATOR SWITCH**

Install and torque the transfer indicator switch.

Torque: 380 kg-cm (27 ft-lb, 37 Nm)

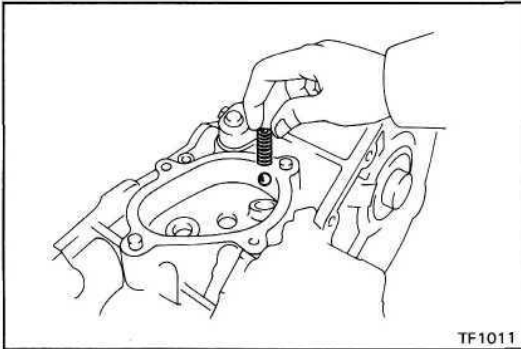
**25. INSTALL BALL, SPRING AND SCREW PLUG**

(a) Install the ball and spring.

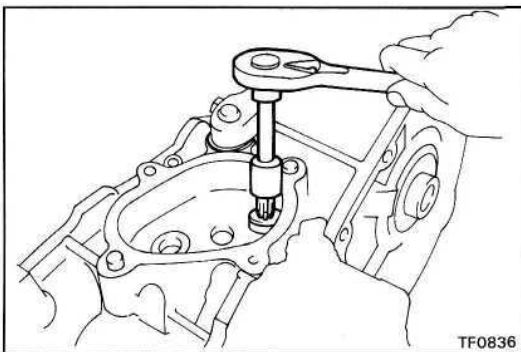

(b) Apply liquid sealer to the screw plug.

**Sealant: Part No.08833-00080, THREE BOND 1344.
LOCTITE 242 or equivalent**

(c) Install and torque the screw plug.

Torque: 190 kg-cm (14 ft-lb, 19 Nm)

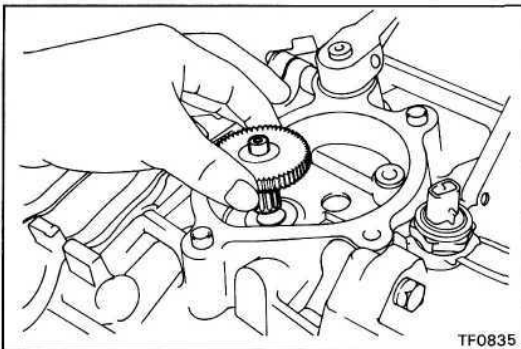
**26. (MOTOR SHIFT TYPE)
INSTALL OUTPUT GEAR**

(a) Coat the gear oil as shown.

(b) Install the output gear.

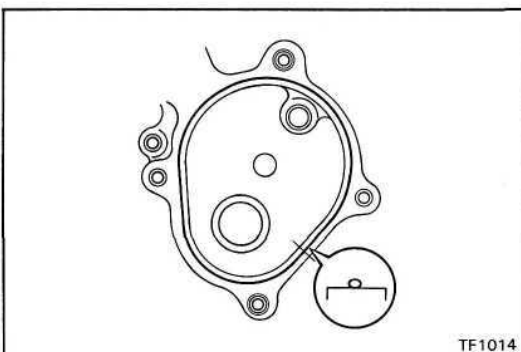
**27. (MOTOR SHIFT TYPE)
INSTALL MOTOR ACTUATOR**

(a) Apply seal packing to the front case as shown.

**Seal packing: Part No.08826-00090, THREE BOND
1281 or equivalent**

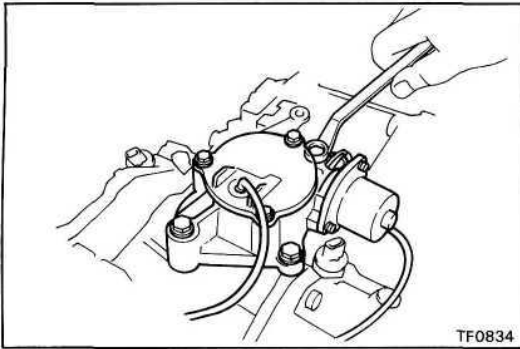

(b) Install the motor actuator.

(c) Install and torque the four bolts.

Torque: 195 kg-cm (14 ft-lb, 19 Nm)

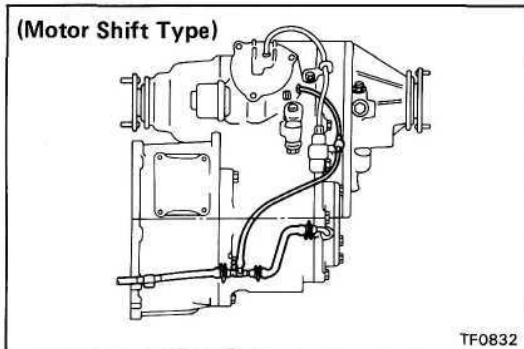

28. INSTALL BREATHER HOSE

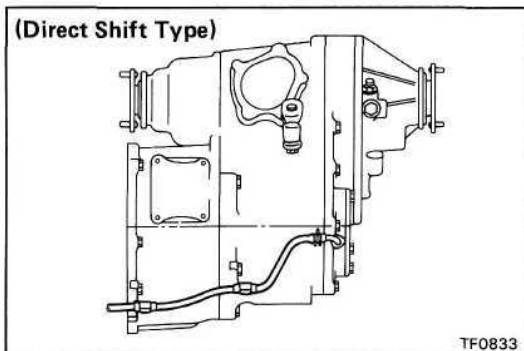

MOTOR SHIFT CONTROL SYSTEM

PARTS LOCATION

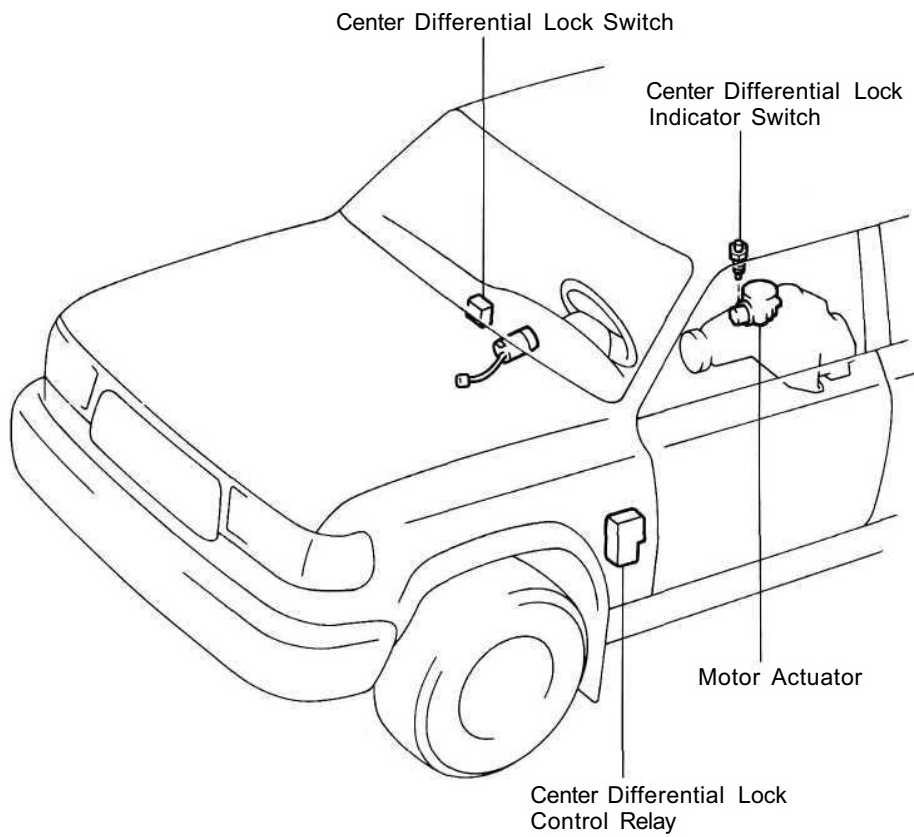

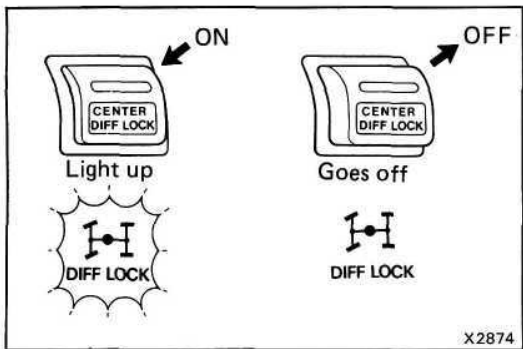

SYSTEM INSPECTION

1. INSPECT CENTER DIFFERENTIAL LOCK SWITCH

- (a) Start the engine and shift the transfer shift lever in H position.
- (b) Check that the center differential lock indicator light comes on when the center differential lock switch is turned ON. Check that the light goes off when the switch OFF.

HINT: There are times when the light will not go off unless the steering is straight ahead and acceleration and deceleration are performed slowly.

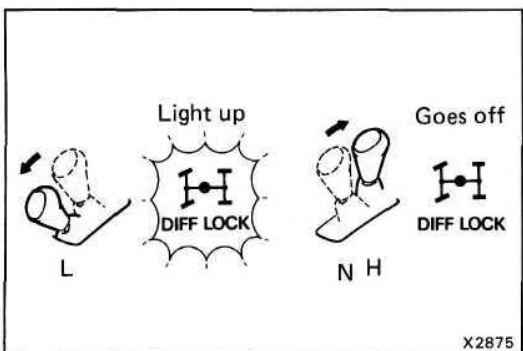

2. INSPECT SHIFT LEVER POSITION

- (a) Start the engine, and center differential lock switch turned to OFF.
- (b) Check that the center differential indicator light comes on when the transfer shift lever shifted to L position. Check that the light goes off when the lever is shifted to N or H position.

Wire Harness Side

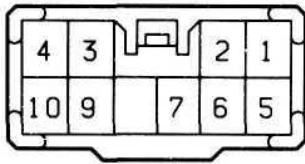

S-10-2

PARTS INSPECTION

1. INSPECT CENTER DIFFERENTIAL LOCK CONTROL RELAY

(a) Check that there is continuity between terminals as shown in the chart.

| 1 | 2 | 3 | 4 | 5 | 6 | 7 | 9 | 10 |
|---|---|---|---|---|---|---|---|----|
| ○ | ○ | | | | | | | |
| | ○ | | ○ | | | | | |
| | | | | | ○ | ⌞ | ○ | |

HINT: There is a diode between terminals 6 and 7. If the circuit shown no continuity, change the positive (+) and negative (—) probes and recheck the circuit.

(b) Apply battery voltage between terminals and check that there is continuity between terminals as shown in the chart.

| Terminal Battery voltage | | 1 | 2 | 3 | 4 | 5 | 6 | 7 | 8 | 9 | 10 |
|--------------------------|----|---|---|---|---|---|---|---|---|---|----|
| + | - | | | | | | | | | | |
| 6 | 5 | ○ | ○ | ○ | | | | | | | |
| 7 | 2 | | | | | | | | | ○ | ○ |
| 9 | 10 | | ○ | ○ | ○ | | | | | | |

○—○: Continuity
○×○: No continuity

If continuity is not as specified, replace the relay.

Motor Actuator Side



IS-6-2

2. INSPECT MOTOR ACTUATOR

(a) Using an ohmmeter, measure the resistance between terminals 2 and 3.

Standard resistance: 0.3 — 100 Q

(b) Using an ohmmeter, measure the resistance between terminals 2 or 3 and body ground.

Standard resistance: More than 0.5 MO

If resistance value is not as specified, replace the motor actuator.

Wire Harness Side

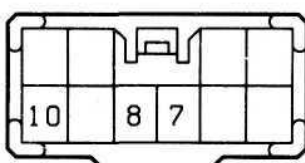

S-10-2

3. INSPECT CENTER DIFFERENTIAL LOCK SWITCH

Check that there is continuity between terminals as shown in the chart.

| Terminal Switch position | 7 | 10 | 8 |
|--------------------------|---|----|---|
| OFF | ○ | ○ | |
| ON | ○ | | ○ |

If continuity is not as specified, replace the switch.

4. INSPECT CENTER DIFFERENTIAL LOCK INDICATOR SWITCH

(See step 3 on page TF-11)

PROPELLER SHAFT

| | Page |
|----------------------|------|
| PRECAUTIONS..... | PR-2 |
| TROUBLESHOOTING..... | PR-2 |
| PROPELLER SHAFT..... | PR-2 |