BRAKE SYSTEM

	Page
PRECAUTIONS.....	BR-2
TROUBLESHOOTING.....	BR-2
CHECKS AND ADJUSTMENTS.....	BR-6
MASTER CYLINDER.....	BR-9
BRAKE BOOSTER.....	BR-16
VACUUM PUMP.....	BR-28
FRONT BRAKE.....	BR-34
REAR BRAKE	
Drum Brake.....	BR-41
Disc Brake.....	BR-50
Parking Brake.....	BR-57
LOAD SENSING PROPORTIONING AND BY-PASS VALVE (LSP & BV).....	BR-66

PRECAUTIONS

1. Care must be taken to replace each part properly as it could affect the performance of the brake system and result in a driving hazard. Replace the parts with parts of the same part number or equivalent.
2. It is very important to keep parts and the area clean when repairing the brake system.

TROUBLESHOOTING

Problem	Possible cause	Remedy	Page
Low or spongy pedal	Linings worn	Replace brake shoes	BR-41, 57
	Leak in brake system	Repair leak	
	Master cylinder faulty	Repair or replace master cylinder	BR-9
	Air in brake system	Bleed brake system	BR-7
	Wheel cylinder faulty	Repair wheel cylinder	BR-41, 57
	Piston seals worn or damaged	Repair brake cylinder	BR-34, 50
	Rear brake automatic adjuster faulty	Repair or replace adjuster	BR-41, 57
Brakes drag	Parking brake out of adjustment	Adjust parking brake	BR-8
	Binding parking brake wire	Repair as necessary	
	Booster push rod out of adjustment	Adjust push rod	BR-16
	Tension or return spring faulty	Replace spring	BR-41, 57
	Brake line restricted	Repair as necessary	
	Lining cracked or distorted	Replace shoe	BR-34, 50
	Wheel cylinder or caliper piston sticking	Repair as necessary	BR-34, 50
	Adjuster broken	Replace adjuster	BR-41, 57
Master cylinder faulty	Repair or replace master cylinder	BR-9	
Brakes pull	Tires improperly inflated	Inflate tires to proper pressure	
	Oil or grease on shoes or pads	Check for cause. Replace shoes or pads	BR-34, 50
	Brake shoes distorted, linings worn or glazed	Replace brake shoes	BR-34, 50
	Brake pads distorted, worn or glazed	Replace pads	BR-34, 50
	Drum or disc out of round	Replace drum or disc	BR-34, 41 50, 57
	Tension or return spring faulty	Replace spring	BR-41, 57
	Wheel cylinder faulty	Repair wheel cylinder	BR-41, 57
	Piston frozen in brake cylinder	Repair cylinder	BR-34, 50
	Brake pad sticking	Replace pads	BR-34, 50

TROUBLESHOOTING (Cont'd)

Problem	Possible cause	Remedy	Page
Hard pedal but brakes inefficient	Oil or grease on linings	Check for cause. Replace shoes or pads	BR-34, 50
	Brake shoes distorted, linings worn or glazed, drums worn	Replace brake shoes	BR-34, 50
	Brake pads distorted, worn or glazed	Replace pads	BR-34, 50
	Piston frozen in brake cylinder	Repair cylinder	BR-34, 50
	Brake booster faulty	Repair booster	BR-16
	Vacuum leaks Brake line restricted	Repair as necessary Repair as necessary	
Snapping or clicking noise when brakes are applied	(Drum brake)		
	Brake shoes binding at backing plate ledges	Lubricate	BR-41, 57
	Backing plate ledges worn	Replace and lubricate ledges	BR-41, 57
	Loose or missing shoe hold-down spring	Replace shoe hold-down spring	BR-41, 57
	Loose set bolt at backing plate	Tighten	BR-41, 45
	(Disk brake) Loose or missing pad support plate Loose installation bolt Wear on slide bushing	Replace pad support plate Tighten Replace slide bushing	BR-34, 50 BR-34, 50 BR-34, 50
Scraping or grinding noise when brakes are applied	Worn brake linings or pads	Replace or refinish drums or rotors if heavily scored	BR-34, 41 50, 57
	Caliper to wheel or rotor interference	Replace as required	BR-34, 50
	Dust cover to rotor or backing plate to drum interference	Correct or replace	BR-34, 50
	Other brake system components faulty	Repair or replace as necessary	
	Tires rubbing against chassis and/or body	Repair as necessary	

TROUBLESHOOTING (Cont'd)

Problem	Possible cause	Remedy	Page
<p>Squeaking, squealing groaning or chattering noise when brakes are applied</p> <p>HINT: Brake friction materials inherently generate noise and heat in order to dissipate energy. As a result, occasional squeal is normal and is aggravated by severe environmental conditions such as cold, heat, wetness, snow, salt, mud, etc. This occasional squeal is not a functional problem and does not indicate any loss of brake effectiveness</p>	Brake drums and linings, rotors and pads worn or scored Dirty, greased, contaminated or glazed linings or pads Improper linings or pads using	Inspect, repair or replace Clean or replace Inspect for correct usage or replace	BR-34, 50 BR-6, 16
	Maladjustment of brake pedal or booster push rod (Disc brake)	Inspect and adjust	BR-6, 16
	Missing or damaged brake pad anti-squeal shim	Replace	BR-34, 50
	Pad wear and pad wear indicator making contact with the rotor	Replace	BR-34, 50
	Burred or rusted calipers (Drum brake)	Clean or deburr	BR-34, 50
	Weak damaged or incorrect shoe hold-down springs, loose or damaged shoe hold-down spring pins and springs and grooved backing plate ledges	Inspect, repair or replace	BR-41, 57
	<p>Squealing and squeaking noise when brakes are not applied</p>	Maladjustment of brake pedal or booster push rod	Inspect and adjust
Poor return of brake booster or master cylinder or wheel cylinder (Disc brake)		Inspect, repair or replace	BR-9, 16
Rusted or stuck piston		Inspect and lubricate as necessary	BR-34, 50
Improper positioning of pad in caliper		Reinstall correctly	BR-34, 50
Rotor rubbing against caliper housing		Inspect and replace	BR-34, 50
Improper installation of disc brake pad support plate		Reinstall correctly	BR-34, 50
Pad wear and pad wear indicator making contact with the rotor (Drum brake)		Replace	BR-34, 50
Weak, damaged or incorrect shoe hold-down springs		Replace	BR-41, 57
Grooved backing plate ledges		Replace	BR-41, 57
Bent or warped backing plate causing interference with drum		Repair or replace	BR-41, 57
Improper machining of drum causing interference with backing plate or shoe		Replace drum	BR-41, 57
Other brake system components: Loose or extra parts in brakes Rear drum adjustment too tight causing lining to glaze Worn, damaged or insufficiently lubricated wheel bearings		Inspect, repair or replace as necessary	BR-41, 57

TROUBLESHOOTING (Cont'd)

Problem	Possible cause	Remedy	Page
Groaning, clicking or rattling noise when brakes are not applied	Stones or foreign material trapped inside wheel covers	Remove foreign material	BR-6, 16
	Loose wheel nuts	Tighten to correct torque Replace if stud holes are elongated	
	Maladjustment of brake pedal or booster push rod	Inspect and adjust	BR-34, 50
	Worn, damaged or dry wheel bearings	Inspect and lubricate or replace	
	(Disc brake) Loose or missing anti-rattle spring or pad support plate or crimping on outer pad	Inspect, repair or replace	BR-34, 50
	Failure of shim	Inspect, replace if necessary	
	Wear on slide bushing	Inspect, replace if necessary	BR-34, 50
	Loose installation bolt	Inspect, tighten if necessary	
	Poor return of piston	Inspect, repair or replace	BR-34, 50
	(Drum brake) Loose or extra parts	Inspect and repair	

CHECKS AND ADJUSTMENTS

CHECK AND ADJUSTMENT OF BRAKE PEDAL

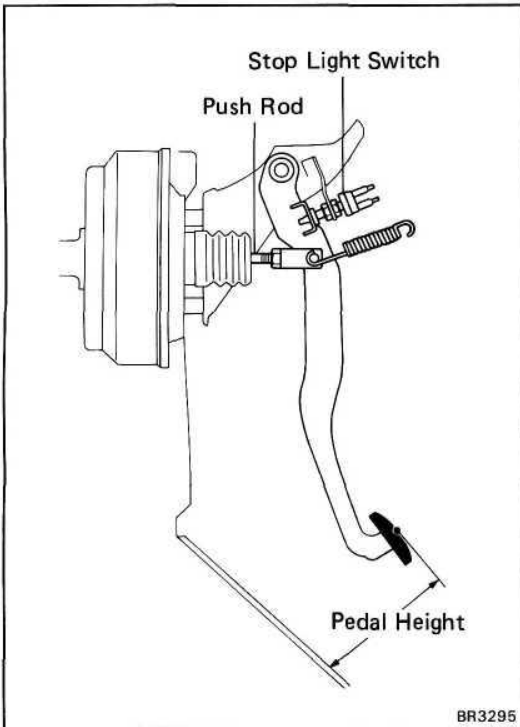

1. CHECK THAT PEDAL HEIGHT IS CORRECT

Pedal height from asphalt sheet:

161 - 171 mm (6.34 - 6.73 in.)

If incorrect, adjust the pedal height.

2. IF NECESSARY, ADJUST PEDAL HEIGHT

- Sufficiently loosen the stop light switch.
- Loosen the clevis lock nut.
- Adjust the pedal height by turning the pedal push rod.
- Return the stop light switch until its body lightly contacts the pedal stopper.
- After adjusting the pedal height, check and adjust the pedal freeplay.
- Tighten the clevis lock nut.

Torque: 375 kg-cm (27 ft-lb, 37 IM-m)

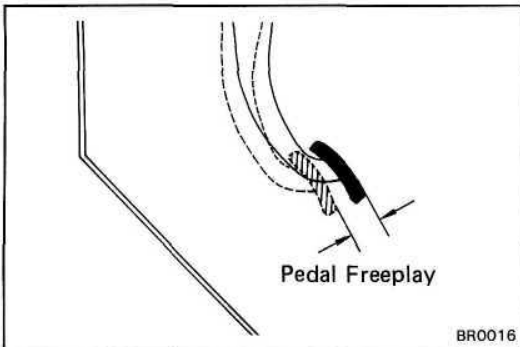

3. CHECK PEDAL FREEPLAY

- Stop the engine and depress the brake pedal several times until there is no more vacuum left in the booster.
- Push in the pedal by hand until the beginning of the second resistance is felt, measure the distance, as shown.

Pedal freeplay: 3 - 6 mm (0.12 - 0.24 in.)

HINT: The freeplay to the first resistance is due to the play between the clevis and pin. And it is 1 — 3 mm (0.04 - 0.12 in.) on the pedal.

4. IF NECESSARY, ADJUST PEDAL FREEPLAY

- If incorrect, adjust the pedal freeplay by turning the pedal push rod.
- Start the engine and confirm that pedal freeplay exists.
- After adjusting the pedal freeplay, check the pedal height.

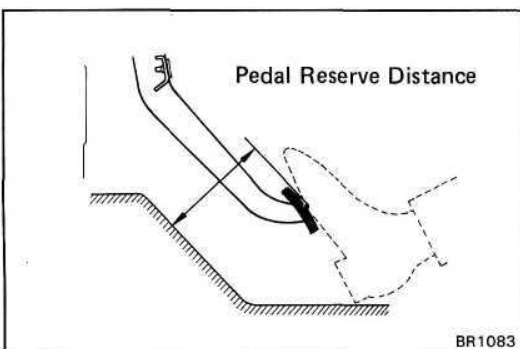

5. CHECK THAT PEDAL RESERVE DISTANCE IS CORRECT

Release the parking brake lever.

With the engine running, depress the pedal and measure the pedal reserve distance, as shown.

Pedal reserve distance from asphalt sheet at 50 kg (110 lb, 490 N): More than 59 mm (2.32 in.)

If incorrect, troubleshoot the brake system.

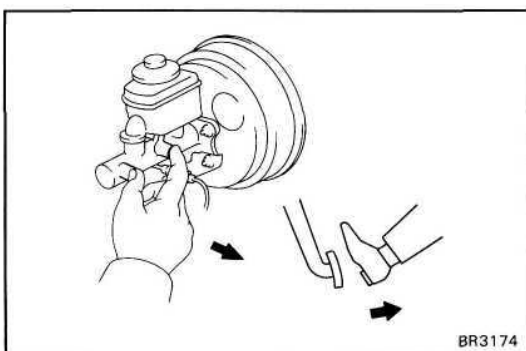
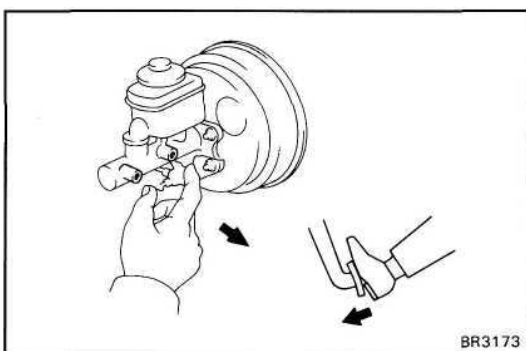
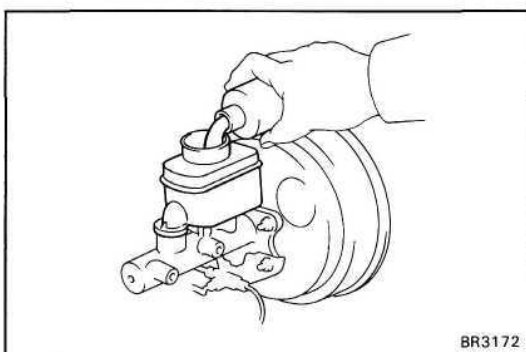
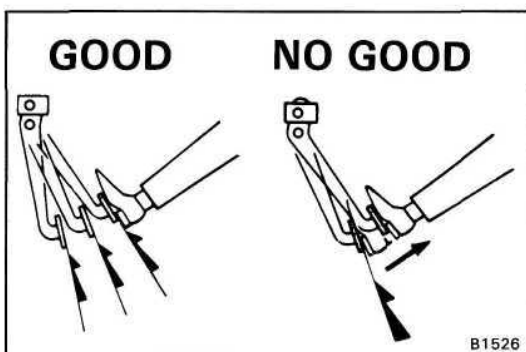
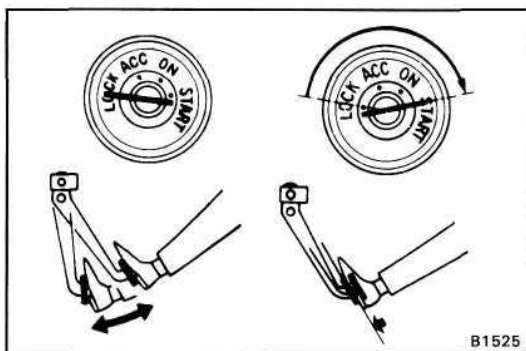

OPERATIONAL TEST OF BRAKE BOOSTER

HINT: If the booster leaks or lacks of vacuum, repair before testing.

1. OPERATING CHECK

- Depress the brake pedal several times with the engine off, and check that there is no change in the pedal reserve distance.
- Depress the brake pedal and start the engine. If the pedal goes down slightly, operation is normal.

2. AIR TIGHTNESS CHECK

- Start the engine and stop it after one or two minutes. Depress the brake pedal several times slowly. If the pedal goes down the farthest the first time, but gradually rises after the second or third time, the booster is air tight.
- Depress the brake pedal while the engine is running, and stop it with the pedal depressed. If there is no change in pedal reserve travel after holding the pedal for thirty seconds, the booster is air tight.

BLEEDING OF BRAKE SYSTEM

HINT: If any work is done on the brake system or if air is suspected in the brake lines, bleed the system of air.

NOTICE: Do not let brake fluid remain on a painted surface. Wash it off immediately.

1. FILL BRAKE RESERVOIR WITH BRAKE FLUID

Check the reservoir after bleeding each wheel. Add fluid, if necessary.

Fluid type: SAE J1703 or FMVSS NO. 116 D0T3

2. BLEED MASTER CYLINDER

HINT: If the master cylinder was disassembled or if the reservoir becomes empty, bleed the air from the master cylinder.

- Disconnect the brake tubes from the master cylinder. Use a container to catch the brake fluid.
- Slowly depress the brake pedal and hold it.
- Block off the outlet holes with your fingers, and release the brake pedal.
- Repeat (b) and (c) three or four times.
- Connect the brake tubes to the master cylinder.

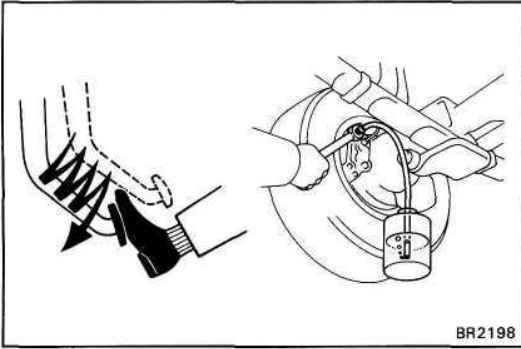

3. CONNECT VINYL TUBE TO WHEEL CYLINDER BLEEDER PLUG

Insert other end of the tube in a half-full container of brake fluid.

HINT: Begin air bleeding from the wheel cylinder with the longest hydraulic line.

4. BLEED AIR FROM BRAKE LINE

- (a) Slowly pump the brake pedal several times.
- (b) While an assistant press on the pedal, loosen the bleeder plug until fluid starts to run out. Then close the bleeder plug.
- (c) Repeat this procedure until there are no more air bubbles in the fluid.

Bleeder plug tightening torque:

110 kg-cm (8 ft-lb, 11 N-m)

5. REPEAT PROCEDURE FOR EACH WHEEL

6. BLEED LOAD SENSING PROPORTIONING AND BY-PASS VALVE

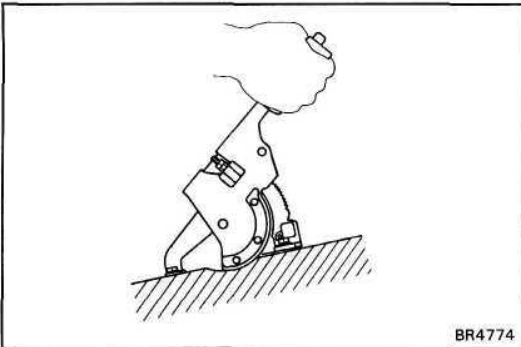

CHECK AND ADJUSTMENT OF PARKING BRAKE

1. CHECK THAT PARKING BRAKE LEVER TRAVEL IS CORRECT

Pull the parking brake lever all the way up, and count the number of clicks.

Parking brake lever travel at 20 kg (44.1 lb, 196 N):

7 - 9 clicks

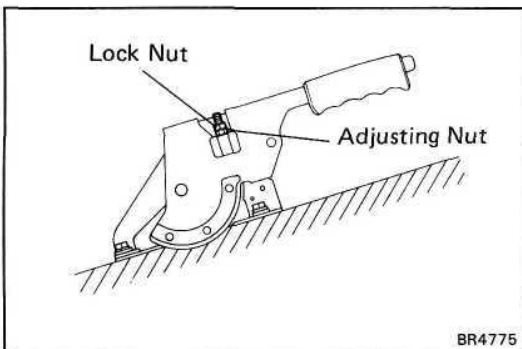

2. IF NECESSARY, ADJUST PARKING BRAKE LEVER TRAVEL

HINT: Before adjusting the parking brake, make sure that the rear brake shoe clearance has been adjusted.

For shoe clearance adjustment, see step 9 on page BR-49 or see step 11 on page BR-65.

- (a) Remove the parking brake lever cover.
- (b) Loosen the lock nut and turn the adjusting nut until the travel is correct.
- (c) Tighten the adjusting cap.
- (d) Install the parking brake lever cover.

MASTER CYLINDER COMPONENTS

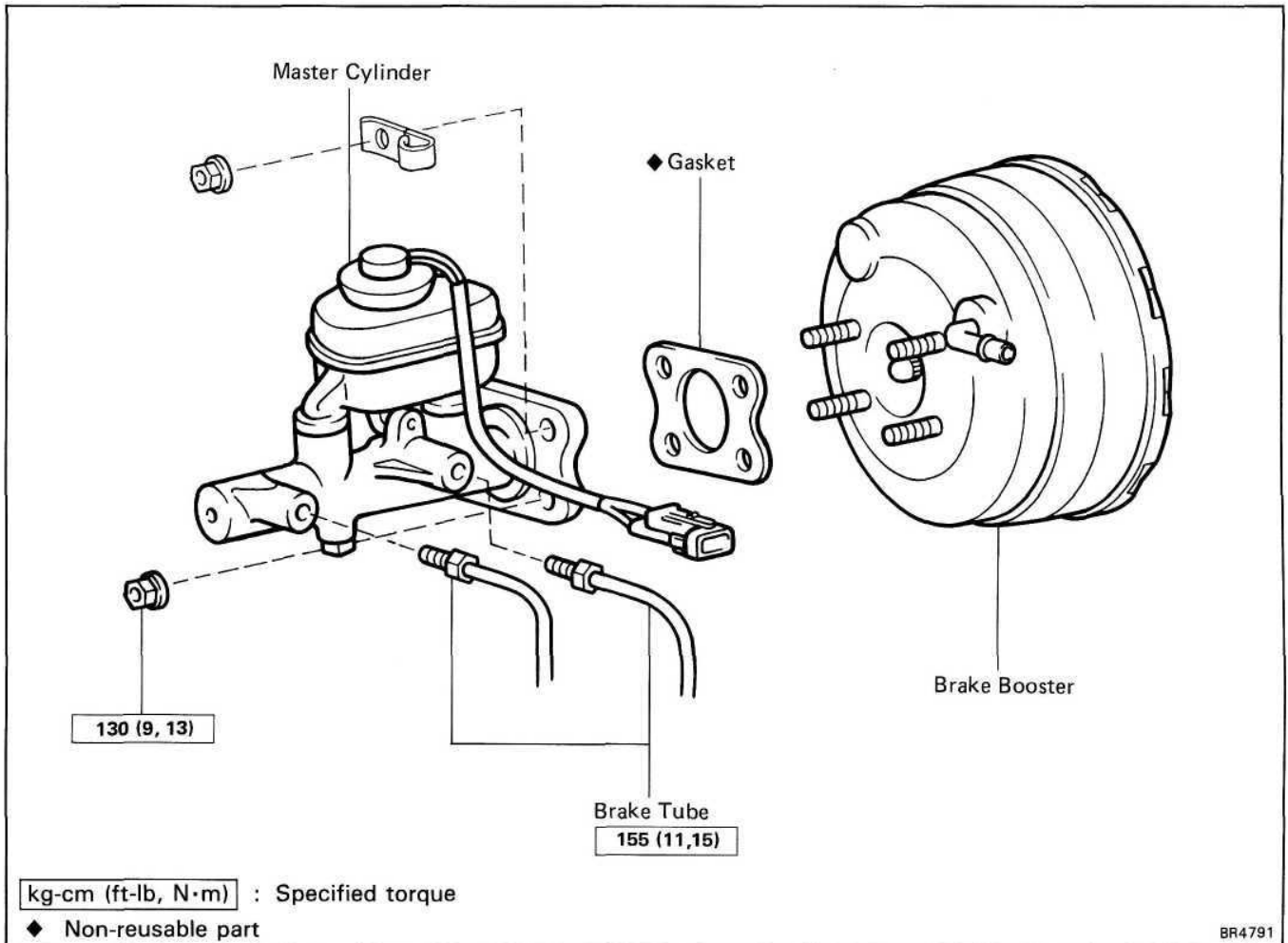

REMOVAL OF MASTER CYLINDER

1. DISCONNECT LEVEL WARNING SWITCH CONNECTOR
2. DRAW OUT FLUID WITH SYRINGE

NOTICE: Do not let brake fluid remain on a painted surface. Wash it off immediately.

3. DISCONNECT TWO BRAKE TUBES

Using SST, disconnect two brake tubes from the master cylinder.

SST 09751-36011

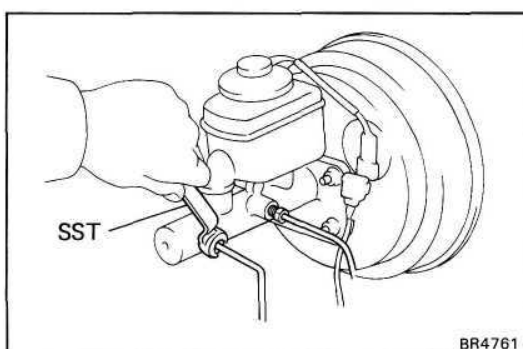

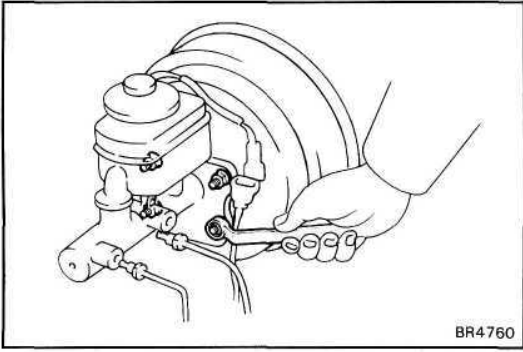

4. REMOVE MASTER CYLINDER

- (a) Remove the four nuts.
- (b) Remove the master cylinder, clamp and gasket from the brake booster.

COMPONENTS

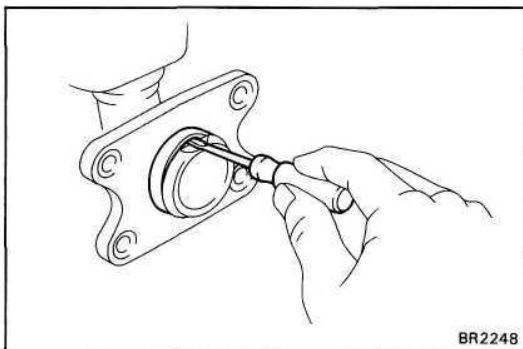
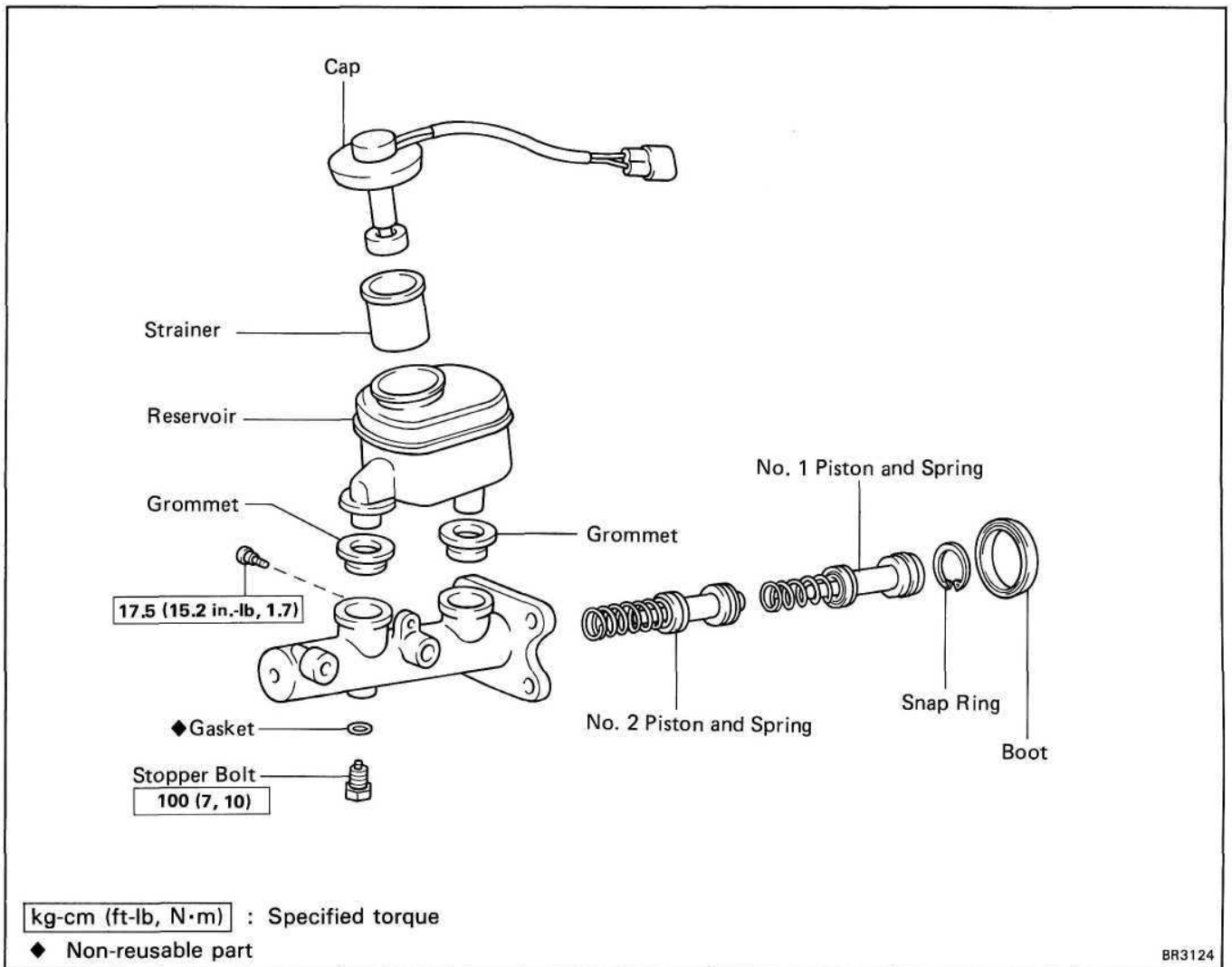

DISASSEMBLY OF MASTER CYLINDER

1. REMOVE MASTER CYLINDER BOOT

Using a screwdriver, remove the master cylinder boot.

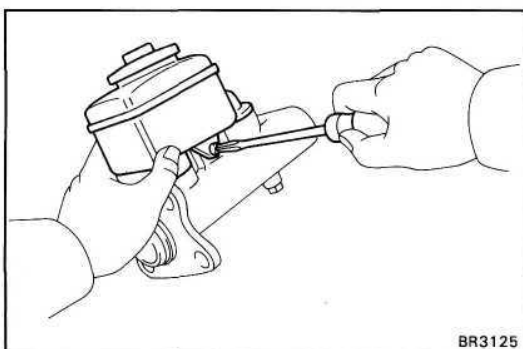

2. REMOVE RESERVOIR

(a) Remove the set screw and pull out the reservoir.

(b) Remove the cap and strainer from the reservoir.

3. REMOVE TWO GROMMETS

4. PLACE CYLINDER IN VISE

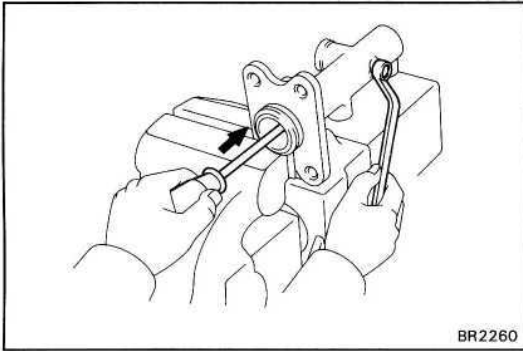

5. REMOVE PISTON STOPPER BOLT

Using a screwdriver, push the pistons in all the way and remove the piston stopper bolt and gasket.

HINT: Tape the screwdriver tip before use.

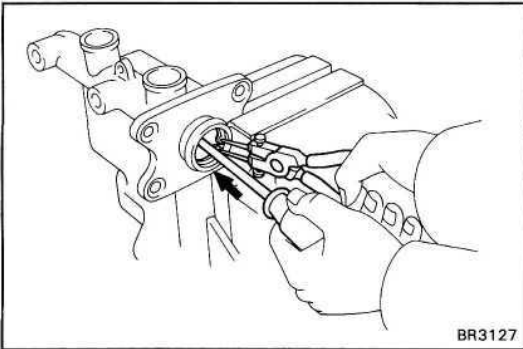

6. REMOVE TWO PISTONS AND SPRINGS

(a) Push in the piston with a screwdriver and remove the snap ring with snap ring pliers.

(b) Remove the No.1 piston and spring by hand, pulling straight out, not at an angle.

NOTICE: If pulled out at an angle, there is possibility of damaging the cylinder bore.

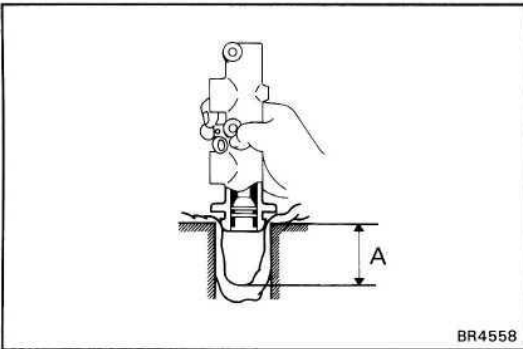

(c) Place a rag and two wooden block on the work table and lightly tap the cylinder flange against the block edges until the piston drops out of the cylinder.

HINT: Make sure the distance (A) from the rag to the top of the block is at least 100 mm (0.394 in.)

INSPECTION OF MASTER CYLINDER COMPONENTS

HINT: Clean the disassembled parts with compressed air.

1. INSPECT CYLINDER BORE FOR RUST AND SCORING

2. INSPECT CYLINDER FOR WEAR OR DAMAGE

If necessary, clean or replace the cylinder.

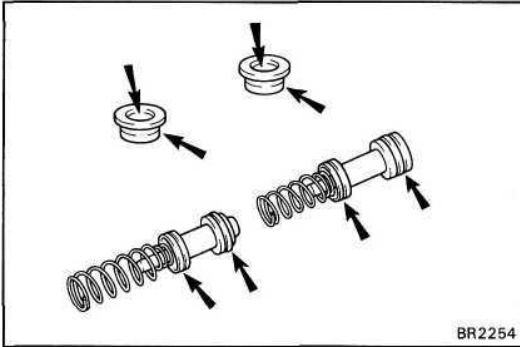

ASSEMBLY OF MASTER CYLINDER

(See page BR-11)

1. APPLY LITHIUM SOAP BASE GLYCOL GREASE TO RUBBER PARTS INDICATED BY ARROWS

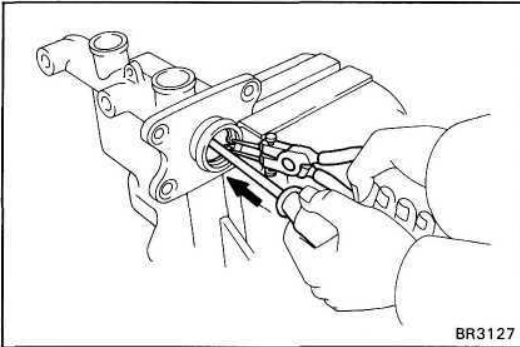

2. INSTALL TWO SPRING AND PISTONS

NOTICE: Be careful not to damage the rubber lips on the pistons.

- (a) Insert two springs and pistons straight in, not at an angle.

NOTICE: If inserted at an angle, there is possibility of damaging the cylinder bore.

- (b) Push in the piston with a screwdriver and install the snap ring with snap ring pliers.

HINT: Tape the screwdriver tip before use.

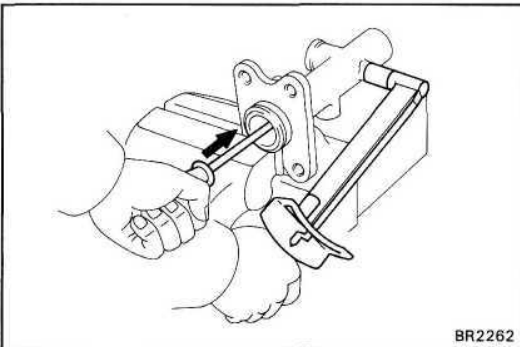

3. INSTALL PISTON STOPPER BOLT AND NEW GASKET

Using a screwdriver, push the pistons in all the way and install the piston stopper bolt over a new gasket.

Torque the bolt.

Torque: 100 kg-cm (7 ft-lb, 10 N-m)

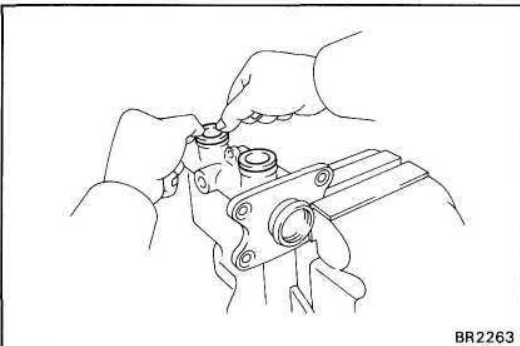

4. INSTALL TWO GROMMETS

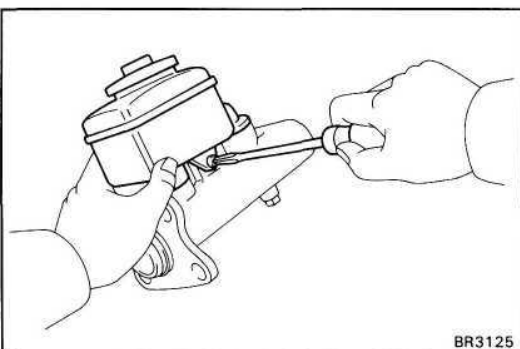

5. INSTALL RESERVOIR

- (a) Install the cap and strainer to the reservoir.

- (b) Install the reservoir onto the cylinder.

- (c) Install the set screw while pushing on the reservoir.

Torque: 17.5 kg-cm (15.2 in.-lb, 1.7 N-m)

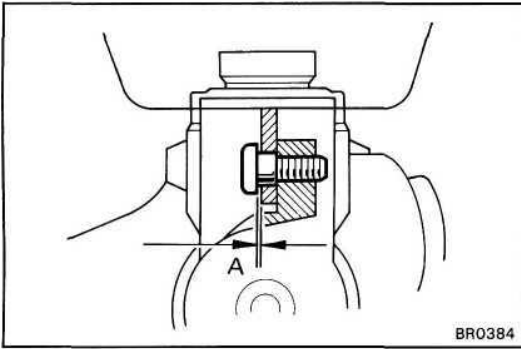

NOTICE: Because the master cylinder and reservoir tank union is a grommet type, the set screw is designed not to separate the reservoir from the cylinder and will not tighten down the reservoir.

Therefore, there is a clearance at point A. Do not insert washers or an equivalent when tightening.

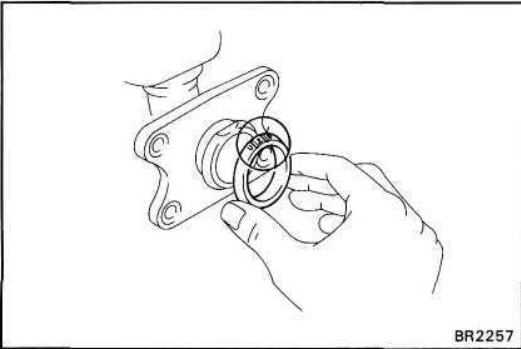

6. INSTALL MASTER CYLINDER BOOT

Facing the up mark on the master cylinder boot upwards, install the cylinder boot to the master cylinder.

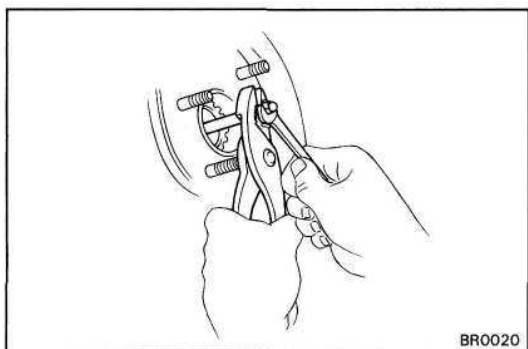

INSTALLATION OF MASTER CYLINDER

1. **ADJUST LENGTH OF BRAKE BOOSTER PUSH ROD BEFORE INSTALLING MASTER CYLINDER**
(See page BR-26)

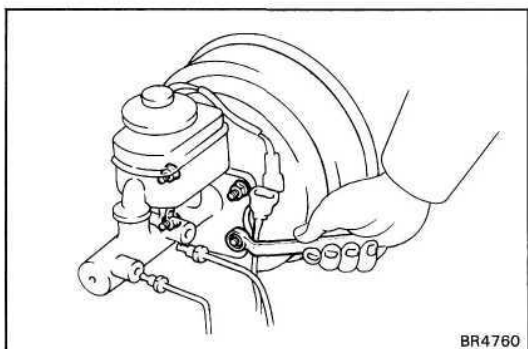

2. **INSTALL MASTER CYLINDER**

Install the master cylinder and clamp on the brake booster with the four nuts over a new gasket.

Torque: 130 kg-cm (9 ft-lb, 13 N-m)

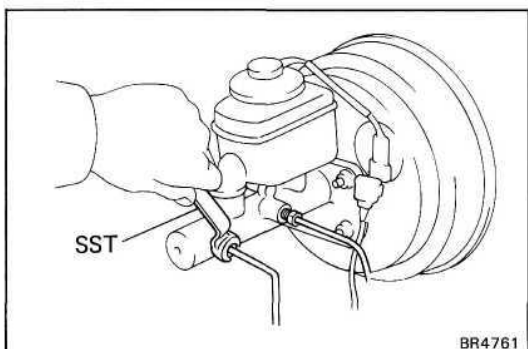

3. **CONNECT TWO BRAKE TUBES**

(a) Finger tighten the union nuts.

(b) Using SST, torque the union nuts.

SST 09751-36011

Torque: 155 kg-cm (11 ft-lb, 15 N-m)

4. **CONNECT LEVEL WARNING SWITCH CONNECTOR**
5. **FILL BRAKE RESERVOIR WITH BRAKE FLUID AND BLEED BRAKE SYSTEM**
(See page BR-7)
6. **CHECK FOR FLUID LEAKAGE**
7. **CHECK AND ADJUST BRAKE PEDAL**
(See page BR-7)

BRAKE BOOSTER

REMOVAL OF BRAKE BOOSTER

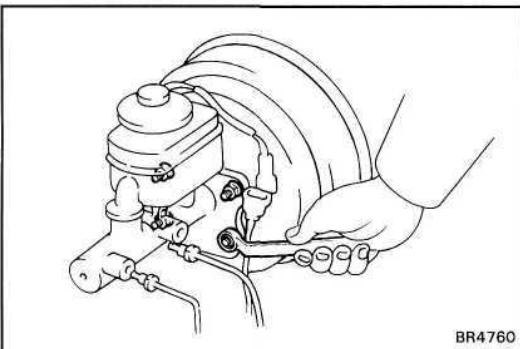
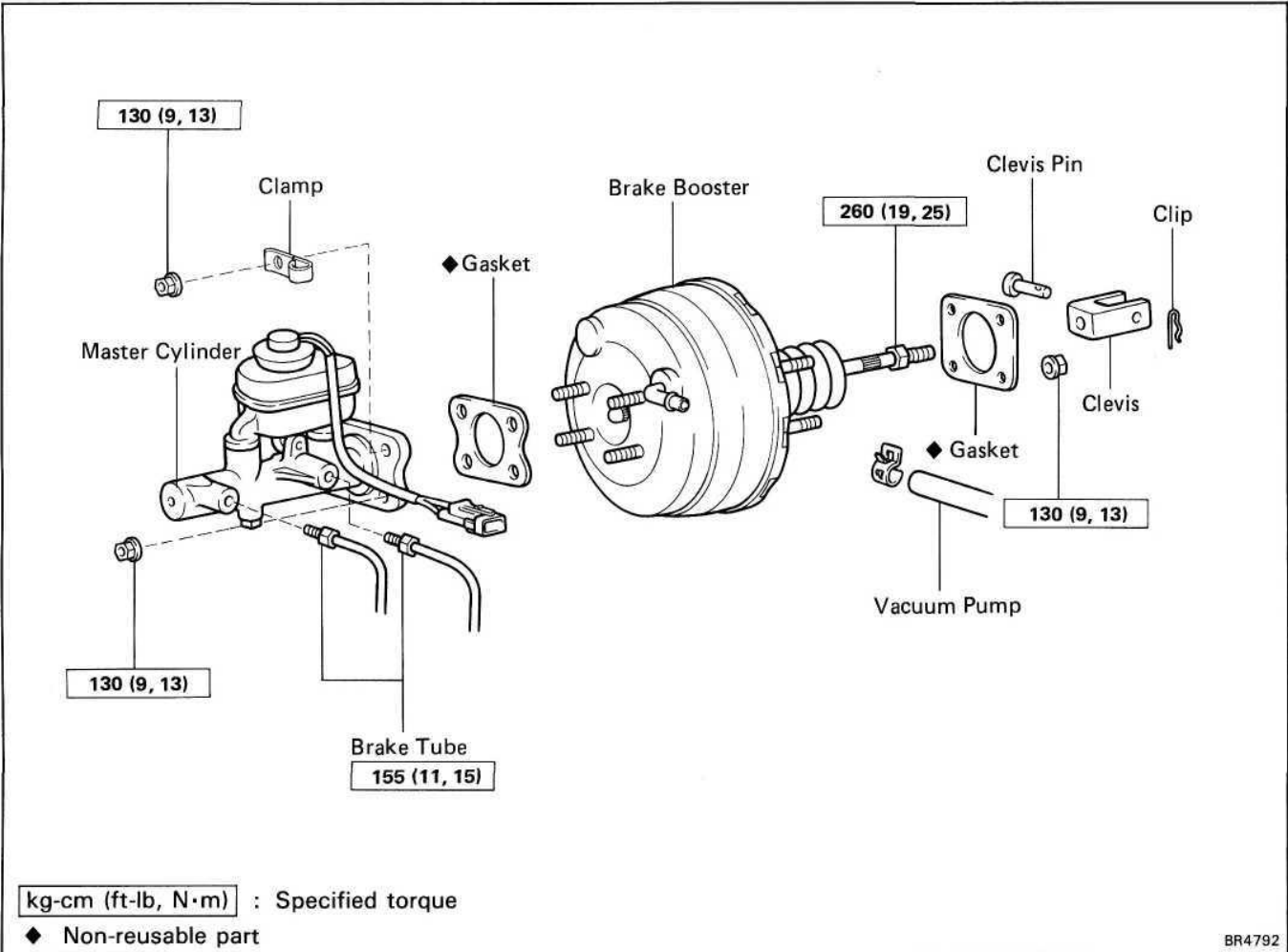

1. REMOVE MASTER CYLINDER
(See page BR-9)
2. DISCONNECT VACUUM HOSE FROM BRAKE BOOSTER

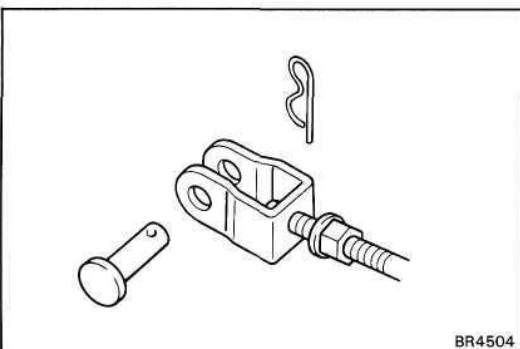

3. REMOVE CLIP AND CLEVIS PIN
 - (a) Remove the clip.
 - (b) Loosen the lock nut.
 - (c) Remove the clevis pin.

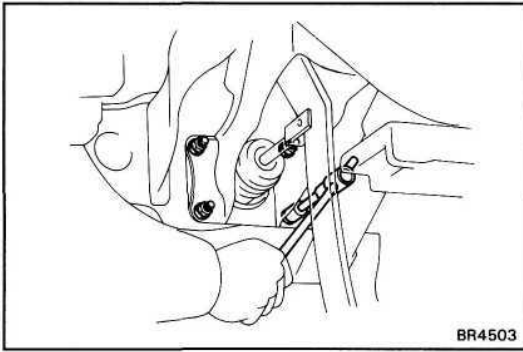

4. REMOVE BRAKE BOOSTER

Remove the four nuts, and pull out the brake booster with gasket.

DISASSEMBLY OF BRAKE BOOSTER

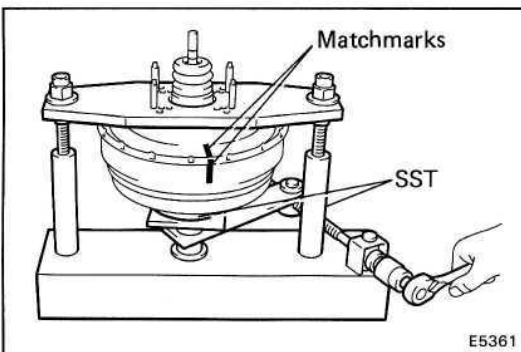
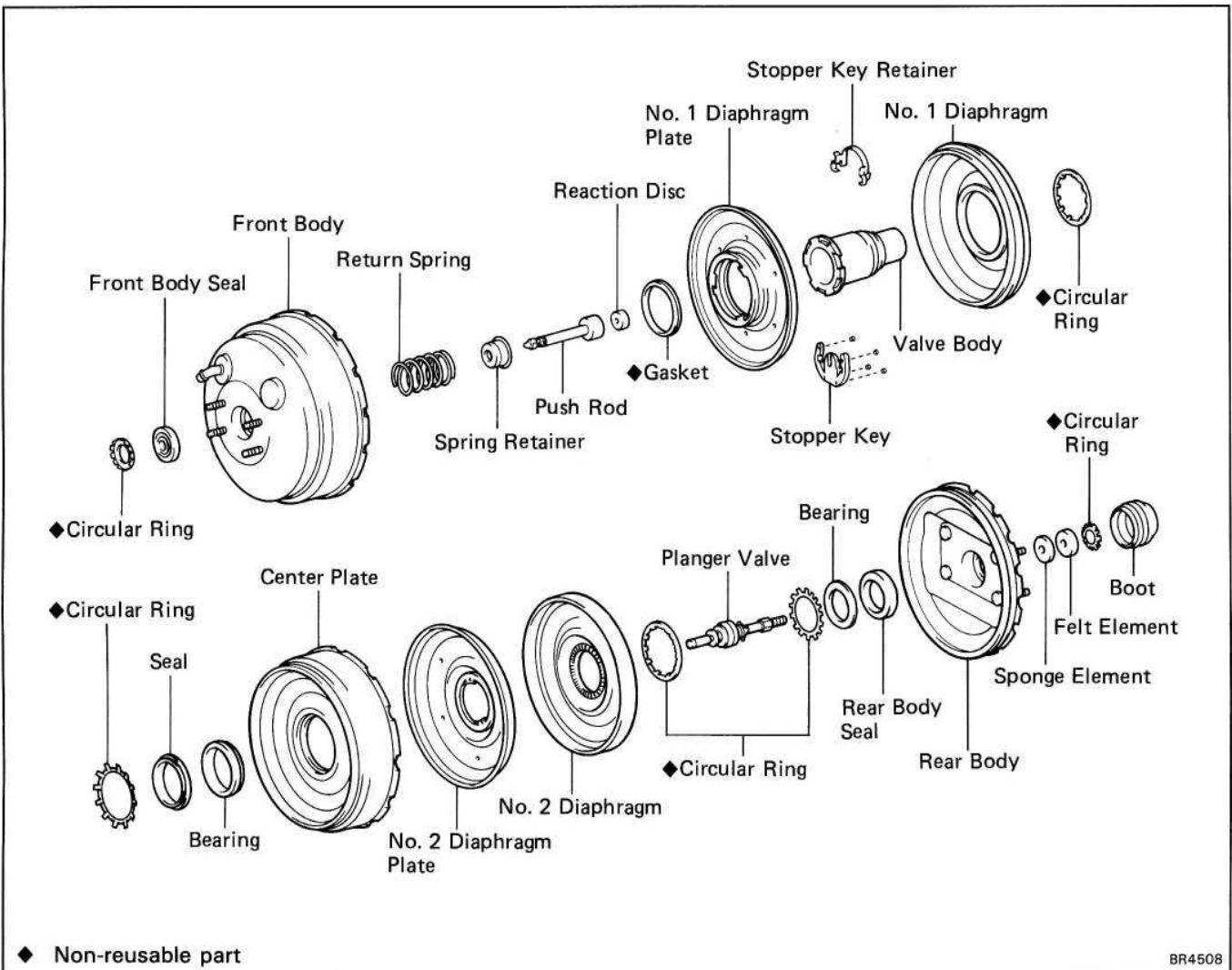

1. SEPARATE FRONT AND REAR BODIES

(a) Set the booster in SST.

SST 09753-00013 and 09753-40010

NOTICE: Be careful not to tighten the two nuts of the SST too tight.

(b) Put matchmarks on the front and rear bodies.

(c) Turn the front body clockwise to separate the front and rear bodies.

(d) Remove the rear body, push rod, spring retainer and piston return spring from the front body.

2. REMOVE BOOT FROM REAR BODY

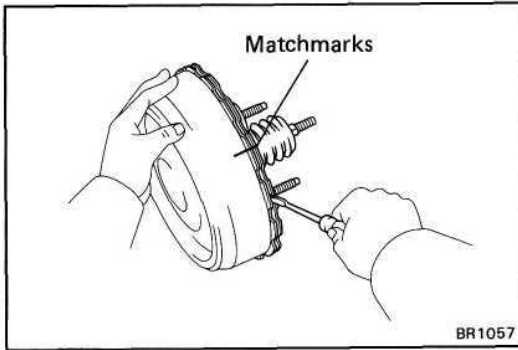

3. REMOVE REAR BODY FROM CENTER PLATE ASSEMBLY

Using a screwdriver, separate and remove the rear body from center plate assembly.

HINT: Tape the screwdriver tip before use.

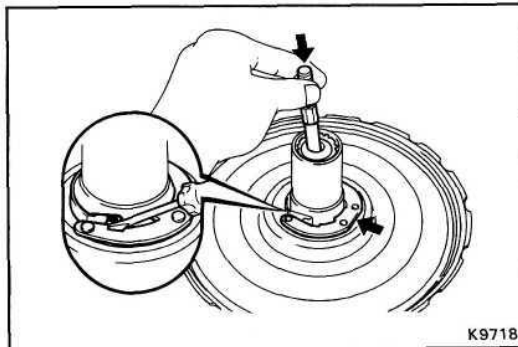

4. REMOVE PLUNGER VALVE

- Using a screwdriver, crush the protrusion of the stopper key retainer as shown in the illustration.
- While pushing in the plunger valve, remove the stopper key.
- Remove the stopper key retainer.

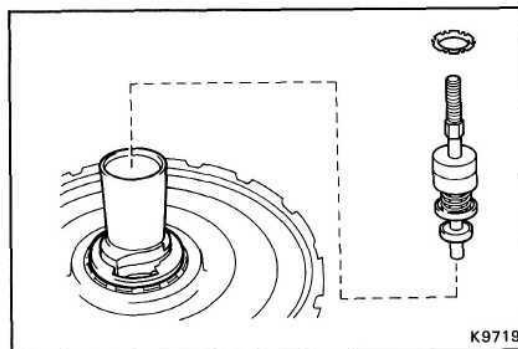

- Using a screwdriver, pry out the circular ring.
- Remove the plunger valve with the sponge and felt elements from the valve body.

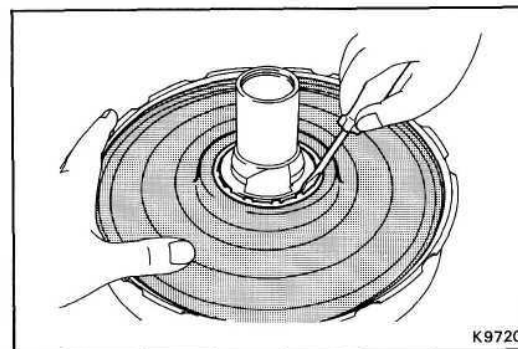

5. REMOVE NO. 2 DIAPHRAGM

- Using a screwdriver, pry out the circular ring.
- Remove the No. 2 diaphragm.
- Remove the No. 2 diaphragm plate.

6. REMOVE CENTER PLATE FROM ASSEMBLY

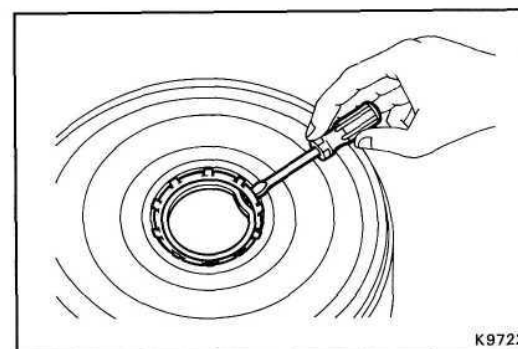

7. REMOVE SEAL AND BEARING FROM CENTER PLATE

- Using a screwdriver, pry out the circular ring from the center plate.
- Remove the seal and bearing.

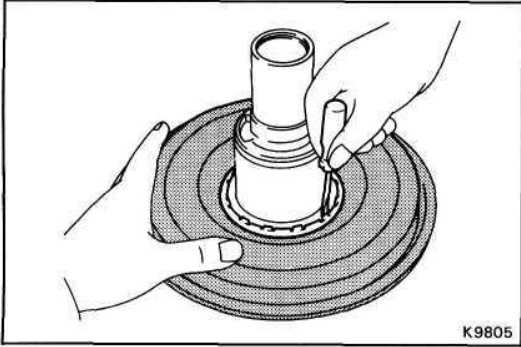

8. REMOVE NO. 1 DIAPHRAGM
- Using a screwdriver, pry out the circular ring.
 - Remove the No. 1 diaphragm.

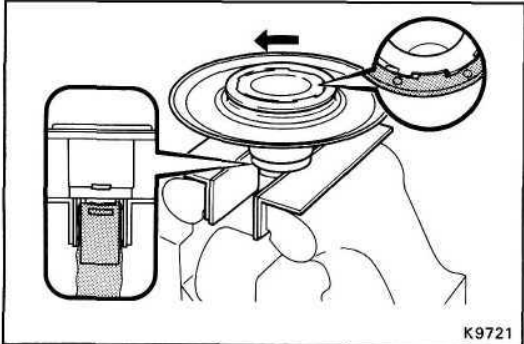

9. REMOVE NO. 1 DIAPHRAGM PLATE
- Wind a cloth or an equivalent to the valve body, and using soft jaws, clamp the diaphragm plate assembly in vise.
- NOTICE: Do not tighten the vise too tight.
- Using a screwdriver, lift up the protrusion of the No. 1 diaphragm plate and turn the plate one third of one turn counterclockwise.
 - Remove the No. 1 diaphragm plate and gasket.

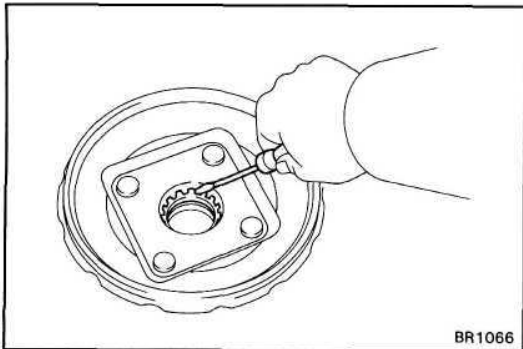

10. REMOVE BODY SEAL AND BEARING FROM REAR BODY
- Using a screwdriver, pry out the circular ring from the rear body.
 - Remove the body seal and bearing.

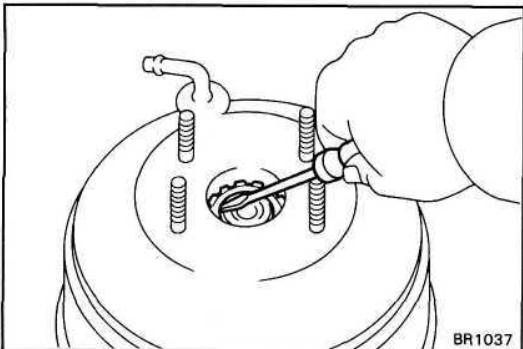

11. REMOVE BODY SEAL FROM FRONT BODY
- Using a screwdriver, pry out the circular ring.
 - Remove the body seal.

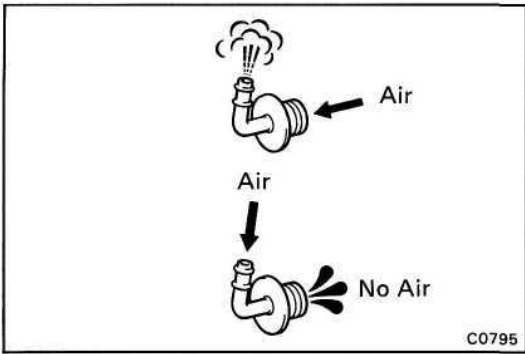

INSPECTION OF BRAKE BOOSTER COMPONENTS

INSPECT CHECK VALVE OPERATION

(Gasoline Engine)

- (a) Remove the check valve.
- (b) Check that air flows from the booster side to the engine side.
- (c) Check that air does not flow from the engine side to the booster side.

If necessary, replace the check valve.

- (d) Install the check valve in place.

(Diesel Engine)

- (a) Remove the check valve from the vacuum tank.
- (b) Check that air flows from the vacuum tank side to the hose side.
- (c) Check that air does not flow from the hose side to the vacuum tank side.

If necessary, replace the check valve.

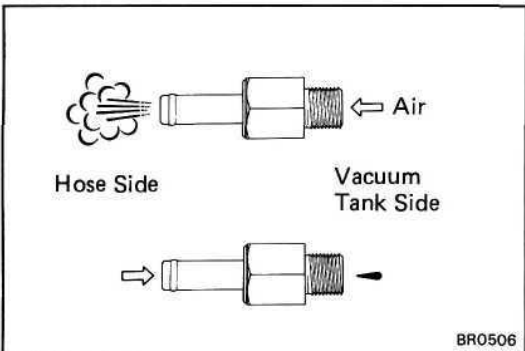

- (d) Apply liquid sealer to the check valve as shown.

Sealant: Part No. 08826-00080 or equivalent

- (e) Install the check valve.

Torque: 300 kg-cm (22 ft-lb, 29 N-m)

- (f) Install the vacuum hose to the check valve with hose clamp.

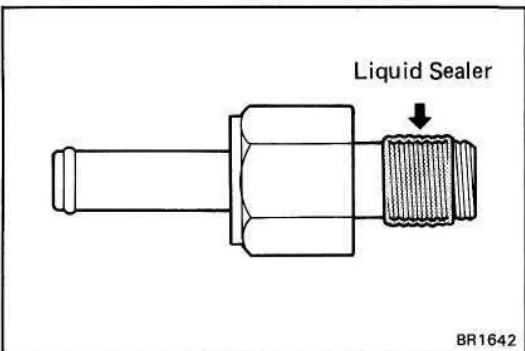

ASSEMBLY OF BRAKE BOOSTER

(See page BR-18)

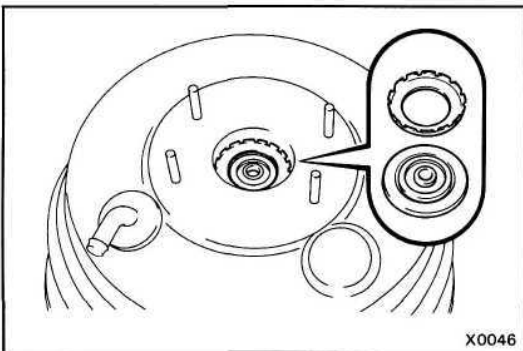
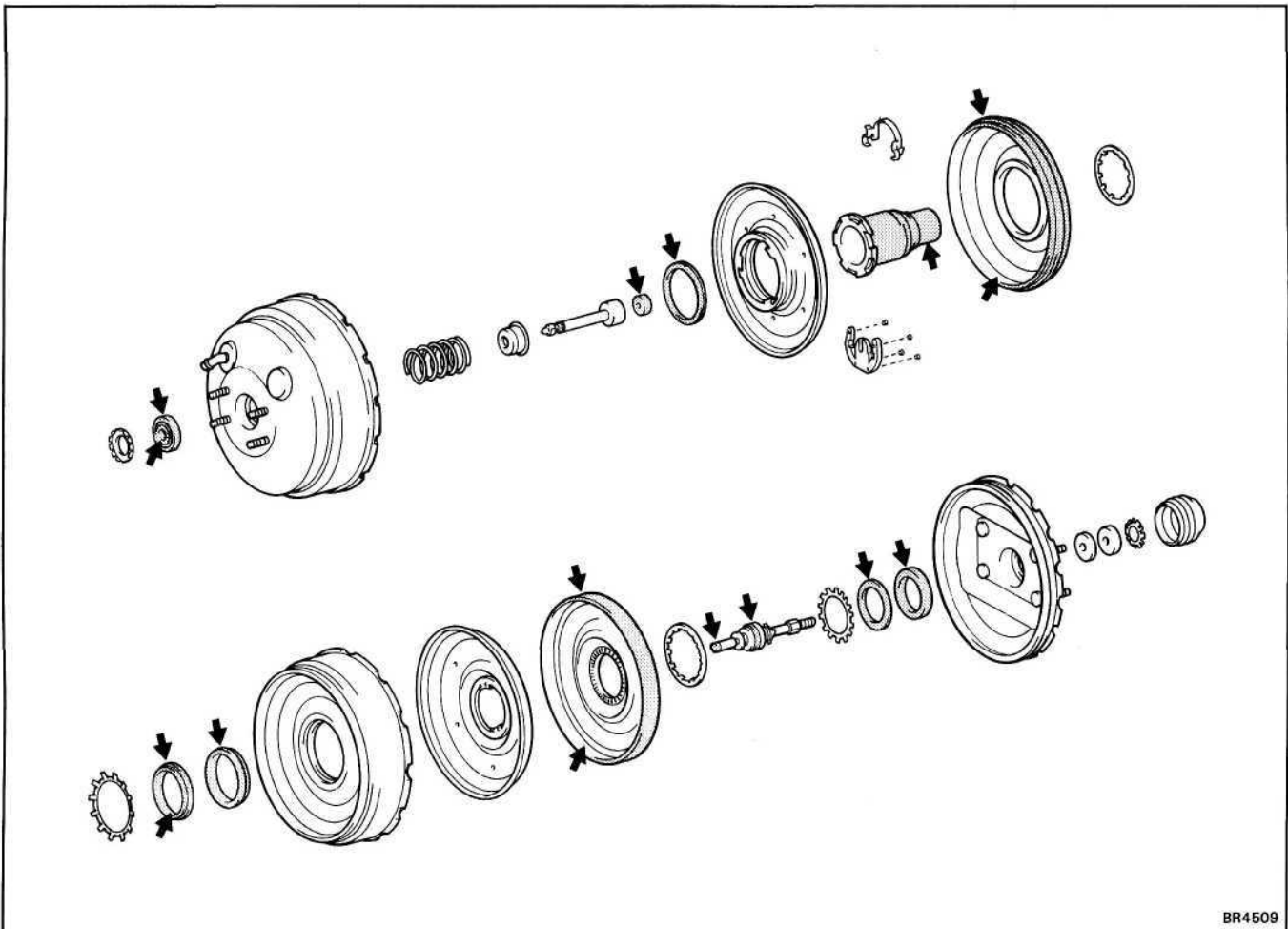
1. APPLY SILICONE GREASE TO PARTS SHOWN BELOW**2. INSTALL BODY SEAL TO FRONT BODY**

- (a) Apply silicone grease to the body seal and install it to the front body.
- (b) Secure the body seal with a new circular ring.

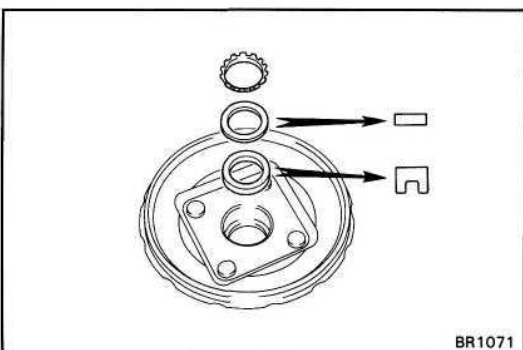
**3. INSTALL BODY SEAL TO REAR BODY**

- (a) Apply silicone grease to the body seal and install it to the rear body.
- (b) Install the bearing and secure the body seal and bearing with a new circular ring.

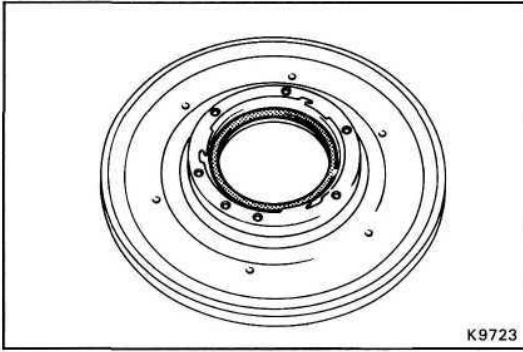

K9723

4. **INSTALL NO. 1 DIAPHRAGM PLATE TO VALVE BODY**
- Install a new gasket to the No. 1 diaphragm plate.
 - Set the No. 1 diaphragm plate on the valve body.

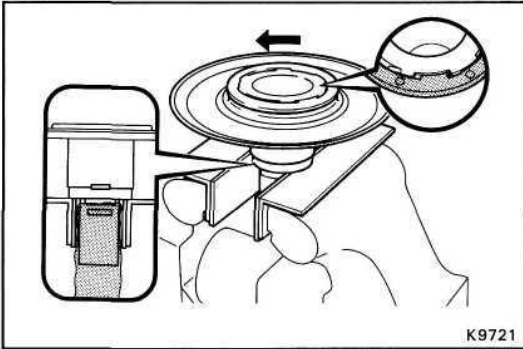

K9721

- Wind a cloth or an equivalent to the valve body, and using soft jaws, clamp the diaphragm plate assembly in the vise.

NOTICE: Do not tighten the vise too tight.

- Align the protrusion of the No. 1 diaphragm plate and cut portion of the valve body, then turn the plate one third of one turn counterclockwise.
- Stake the protrusion of the No. 1 diaphragm plate.

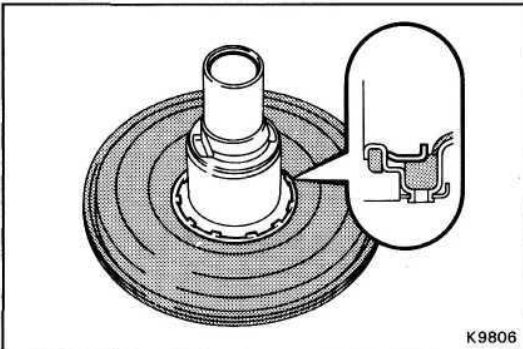

K9806

5. **INSTALL NO. 1 DIAPHRAGM**

- Install the No. 1 diaphragm onto the No. 1 diaphragm plate.
- Secure the diaphragm with the new circular ring.

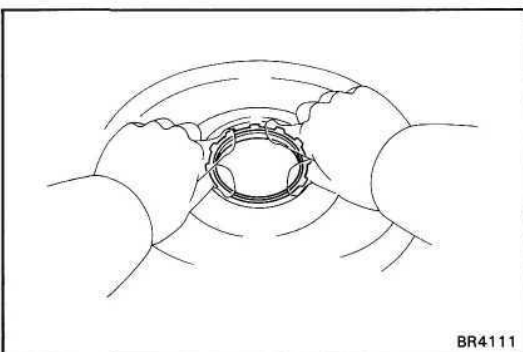

BR4111

6. **ASSEMBLE CENTER PLATE ASSEMBLY**

- Install the bearing and a new circular ring to the seal.
- Install the seal assembly to the center plate.
- Apply silicone grease on the circular ring with the thickness about 2.0 mm (0.79 in.).

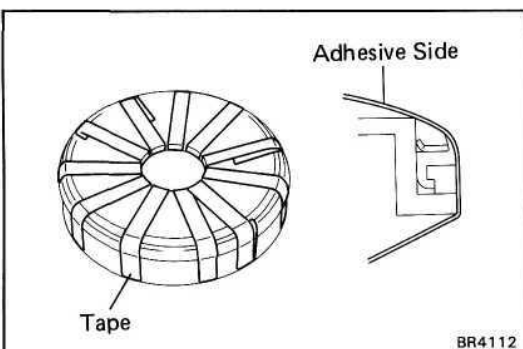

BR4112

- Wind the thin tape to the center plate as shown in the illustration so as not to the seal lip fold under when inserting the valve body.

HINT: Wind the tape so the adhesive side faces the outside.

- Apply silicon grease to the tape and valve body contact portions.

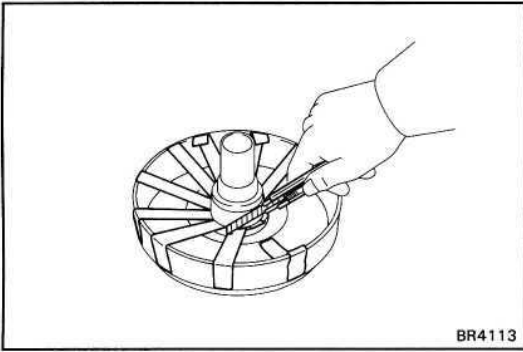

- (f) Install the center plate to the valve body.
NOTICE: Be careful not to the seal lip fold under.
 (g) Cut off the tapes and pull out them.

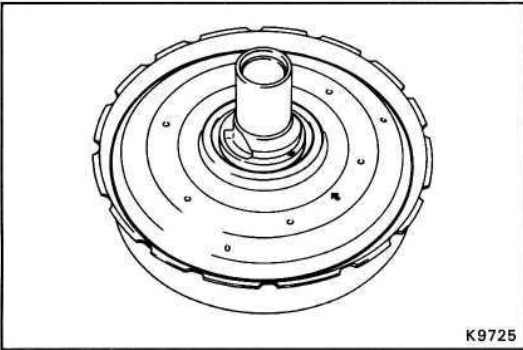

7. INSTALL NO. 2 DIAPHRAGM PLATE

Align the arrows on the valve body and No. 2 diaphragm plate, then install the diaphragm plate to the valve body.

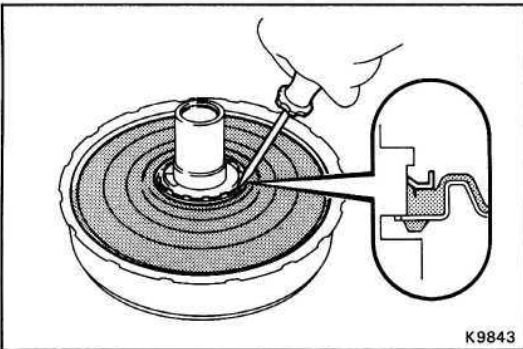

8. INSTALL NO. 2 DIAPHRAGM

- (a) Install the No. 2 diaphragm onto the No. 2 diaphragm plate.
 (b) Secure the diaphragm with a new circular ring.

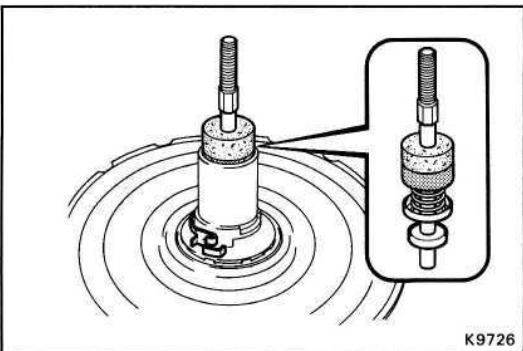

9. INSTALL PLUNGER VALVE

- (a) Install the sponge and felt elements to the plunger valve.
 (b) Install the plunger valve to the valve body.
 (c) Install the stopper key retainer to the valve body.

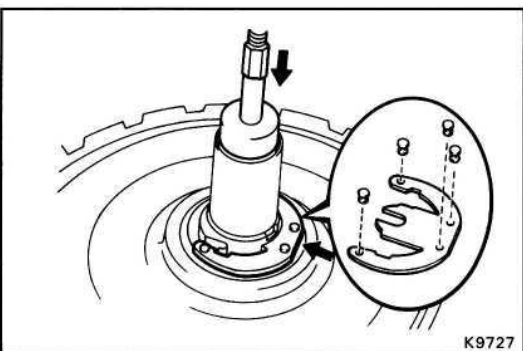

- (d) While pushing in the plunger valve, install the stopper key.

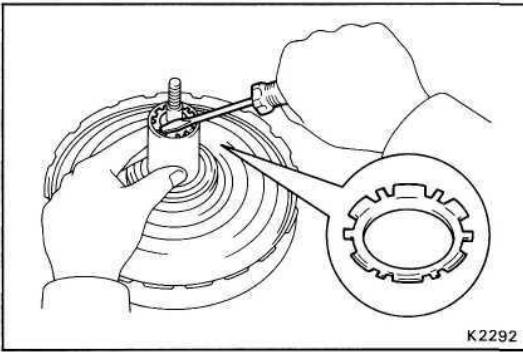

- (e) Secure the plunger valve with a new circular ring.

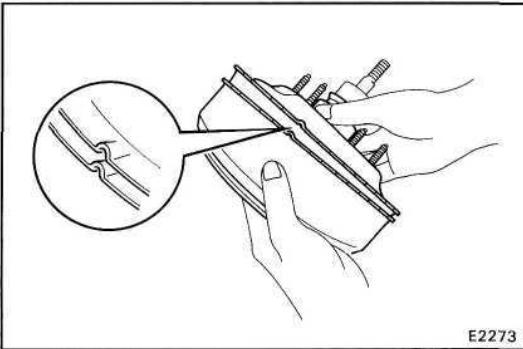

10. INSTALL REAR BODY TO CENTER PLATE ASSEMBLY

Align the each protrusions of the center plate and rear body, install the rear body to the center plate assembly.

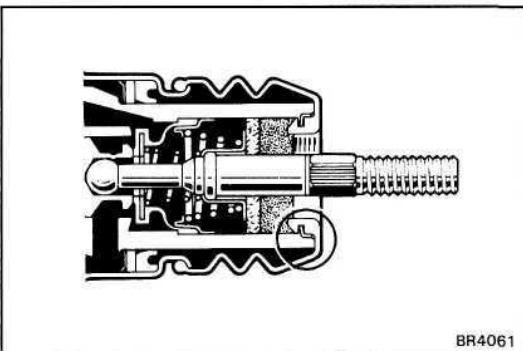

11. INSTALL BOOT

- (a) Install the boot to the assembly.
 (b) Check that the circular ring fit into the groove of the boot as shown in the illustration.

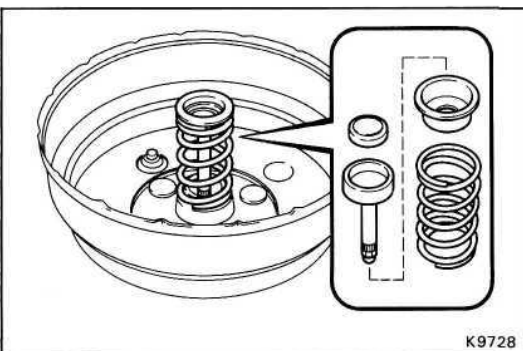

12. ASSEMBLE FRONT AND REAR BODIES

- (a) Place the front body on SST.
 SST 09753-00013 and 09753-40010
 (b) Install the following parts to the front body.
- Return spring
 - Spring retainer
 - Push rod
 - Reaction disc

HINT: Before installing the reaction disc, apply silicon grease to the reaction disc.

- (c) Place the rear body assembly into the front body.
 (d) Using SST, compress the spring between the front and rear bodies.

SST 09753-00013 and 09753-40010

NOTICE: Be careful not to tighten the two nuts of SST too tight.

- (e) Assemble the front and rear bodies by turning the front body counterclockwise until the matchmarks match.

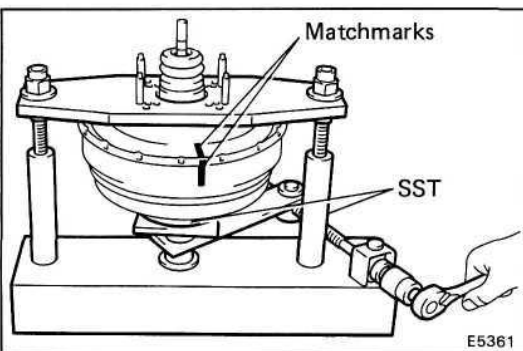

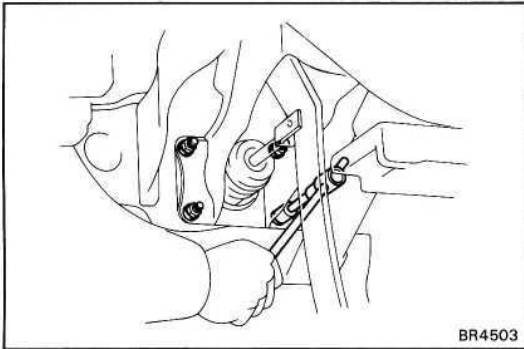

BR4503

INSTALLATION OF BRAKE BOOSTER

(See page BR-18)

1. INSTALL BRAKE BOOSTER

Install the brake booster, and torque four nuts.

Torque: 130 kg-cm (9 ft-lb, 13 N-m)

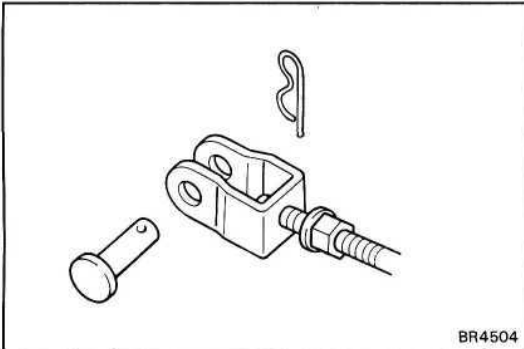

BR4504

2. CONNECT CLEVIS TO BRAKE PEDAL

- (a) Install the clevis pin to the clevis through the brake pedal.
- (b) Secure the pin with a clip.

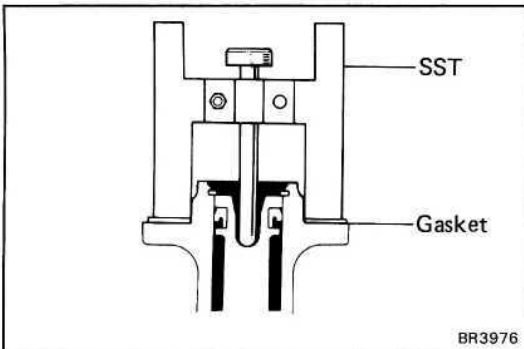

BR3976

3. ADJUST LENGTH OF BOOSTER PUSH ROD

- (a) Install the gasket on the master cylinder.
- (b) Set SST on the master cylinder, and lower the pin until its tip slightly touches the piston.

SST 09737-00010

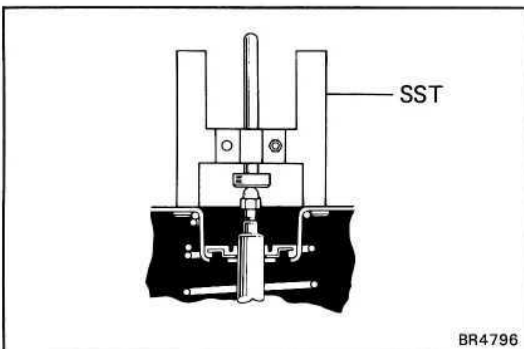

BR4796

- (c) Turn SST upside down, and position it on the booster.
SST 09737-00010
- (d) Measure for clearance between the booster push rod and pin head (SST).

Clearance:

Gasoline Engine 0 mm (0 in.)
Diesel Engine 0.2 mm (0.008 in.)

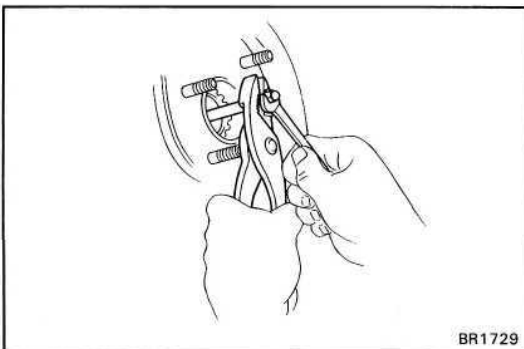

BR1729

- (e) While depressing the brake pedal, adjust the booster push rod length so that the push rod lightly touches the pin head after releasing the brake pedal.
- (f) Measure the clearance again.

4. CONNECT VACUUM HOSE TO BRAKE BOOSTER

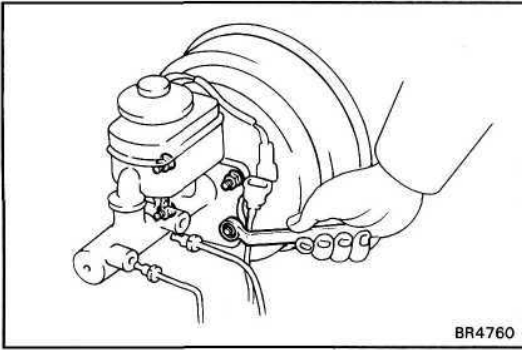

5. **INSTALL MASTER CYLINDER**
(See page BR-9)
6. **FILL BRAKE RESERVOIR WITH BRAKE FLUID AND BLEED BRAKE SYSTEM**
(See page BR-7)
7. **CHECK FOR FLUID LEAKAGE**
8. **CHECK AND ADJUST BRAKE PEDAL**
(See page BR-6)
9. **PERFORM OPERATIONAL CHECK**
(See page BR-7)

VACUUM PUMP COMPONENTS

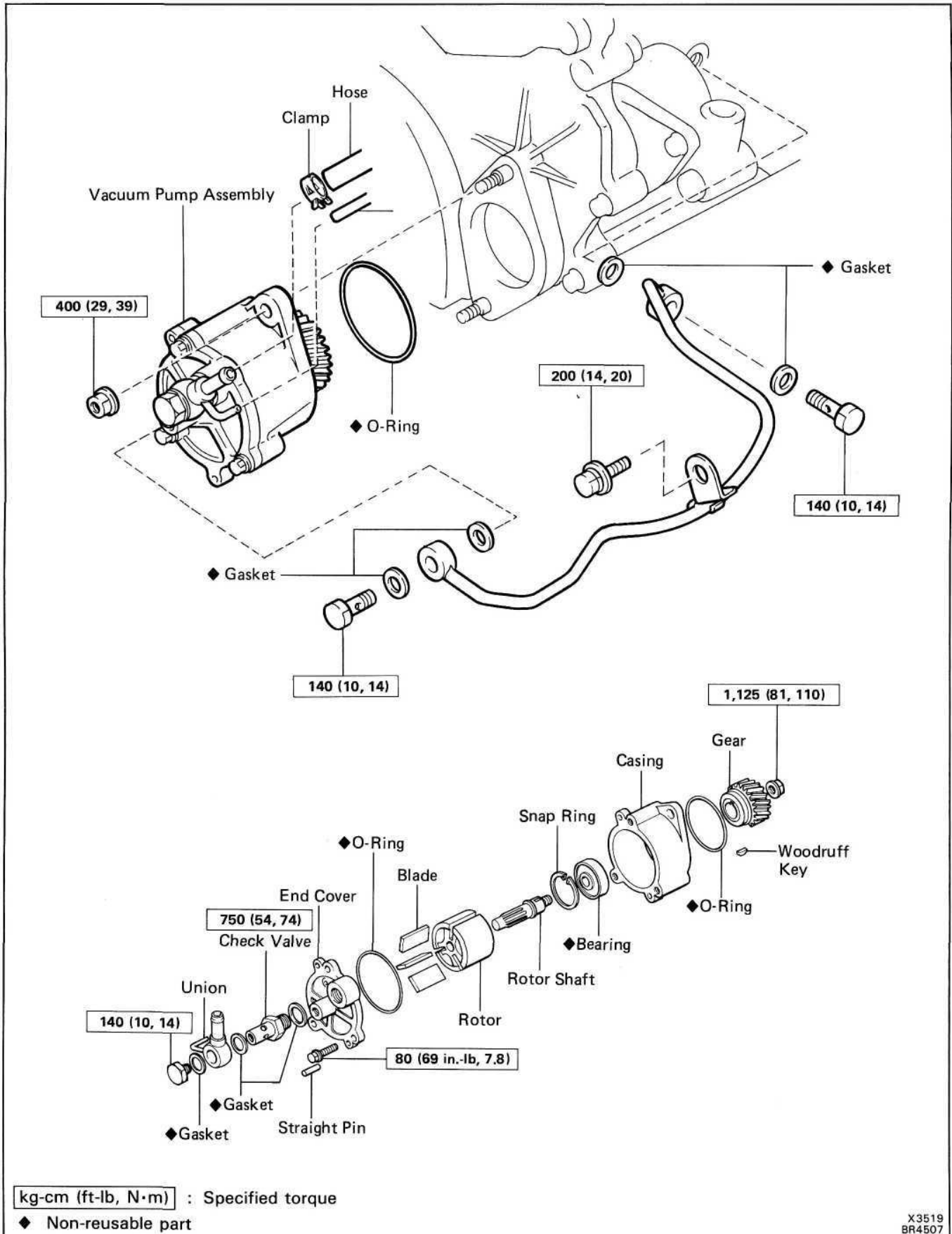

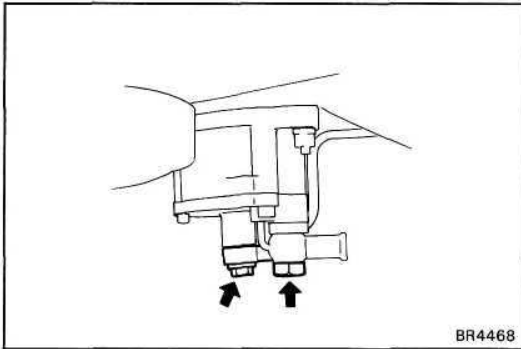

REMOVAL OF VACUUM PUMP

REMOVE VACUUM PUMP

- (a) Remove the two union bolt and disconnect oil tube from the vacuum pump.
- (b) Using pliers, disconnect the two hoses from the vacuum pump.
- (c) Remove the two bolts and remove the pump from the engine.
- (d) Remove the O-ring.

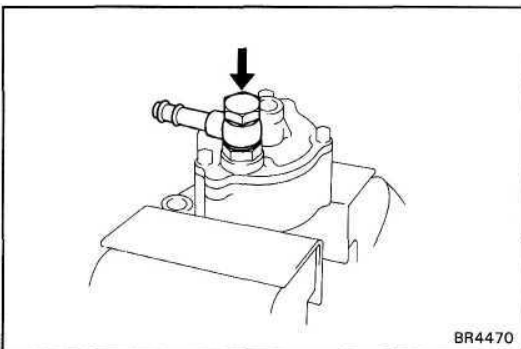
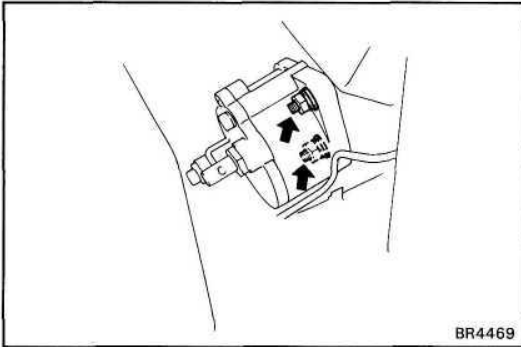

DISASSEMBLY OF VACUUM PUMP

1. REMOVE VACUUM HOSE UNION

- (a) Using soft jaws on the vise, place the vacuum pump in the vise.
- NOTICE: Do not tighten the vise too tight.**
- (b) Remove the union bolt, union and two gaskets.

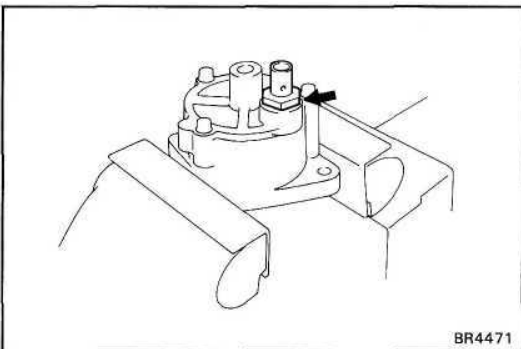

2. REMOVE CHECK VALVE

Remove the check valve and gasket.

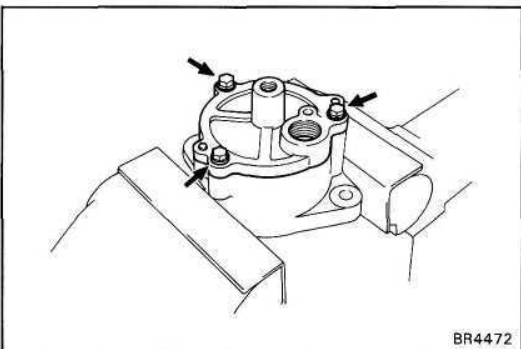

3. REMOVE END COVER

- (a) Remove the three bolts.

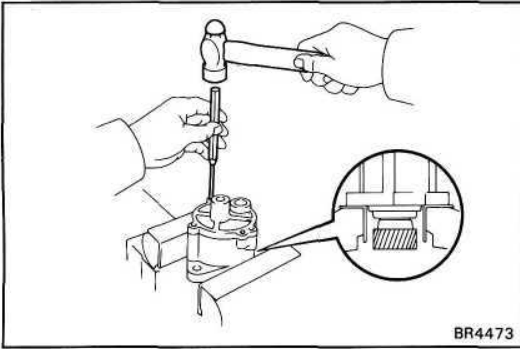

- (b) Place the vacuum pump on vise as shown in the illustration.

NOTICE: Do not tighten the vise.

- (c) Using a pin punch and a hammer, drive out the two straight pins.
 (d) Remove the end cover and O-ring.

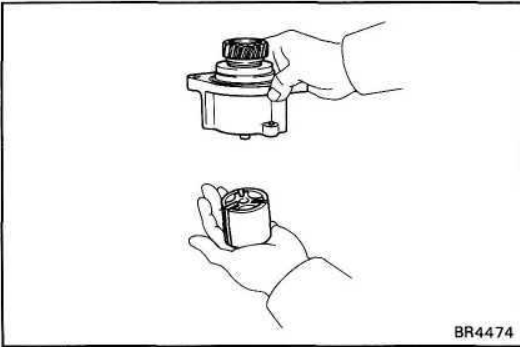

4. REMOVE ROTOR AND THREE BLADES

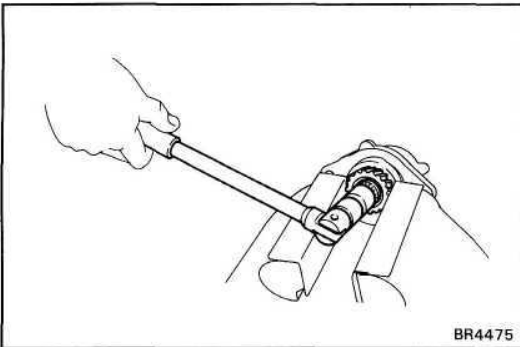

5. REMOVE GEAR

- (a) Using soft jaws on the vise, clamp the gear in the vise.
 (b) Remove the gear lock nut.
 (c) Remove the gear and woodruff key.

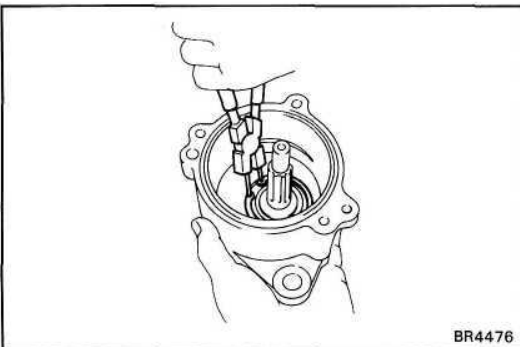

6. REMOVE SNAP RING

Using snap ring pliers, remove the snap ring.

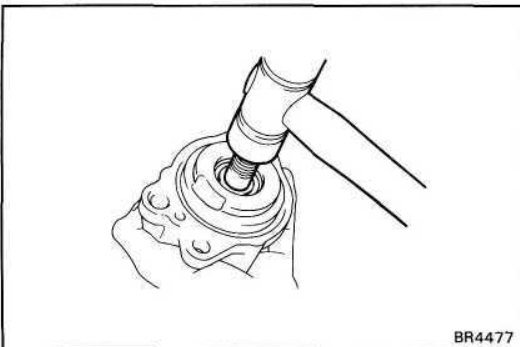

7. REMOVE ROTOR SHAFT

Using a plastic hammer, tap out the rotor shaft.

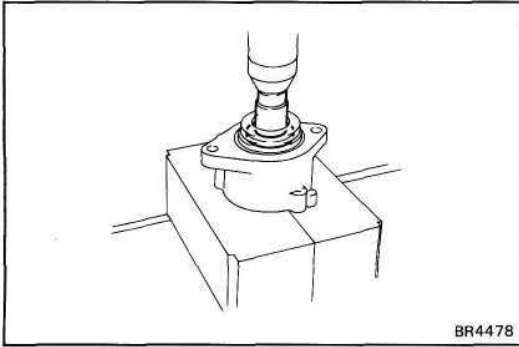

8. REMOVE BEARING

Using a press and 17 mm socket wrench, press out the bearing.

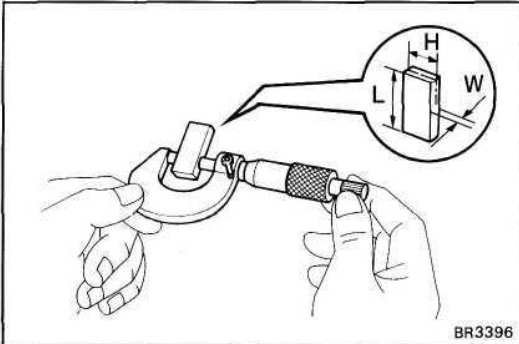

INSPECTION OF VACUUM PUMP

1. INSPECT BLADES

- Check the blades for wear or damage.
- Using a micrometer, measure the height, width and length of the blades.

Minimum height: 16.50 mm (0.6496 in.)

Minimum width: 4.95 mm (0.1949 in.)

Minimum length: 44.96 mm (1.7701 in.)

If necessary, replace the blades.

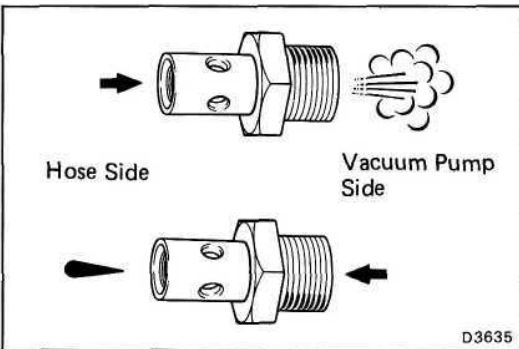

2. INSPECT CHECK VALVE OPERATION

- Check that air flows from the hose side to the pump side.
- Check that air does not flow from the pump side to the hose side.

If necessary, replace the check valve.

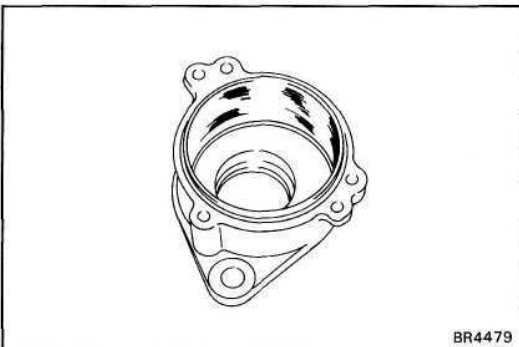

3. INSPECT INSIDE SURFACE OF CASING

Inspect the inside surface of the casing for scoring.

If necessary, replace the vacuum pump assembly.

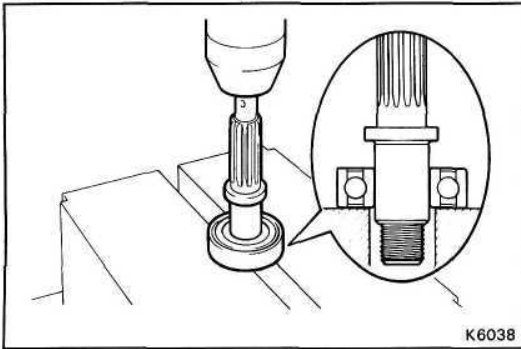

ASSEMBLY OF VACUUM PUMP

(See page BR-28)

1. INSTALL BEARING TO ROTOR SHAFT

Using a press, install a new bearing to the rotor shaft.

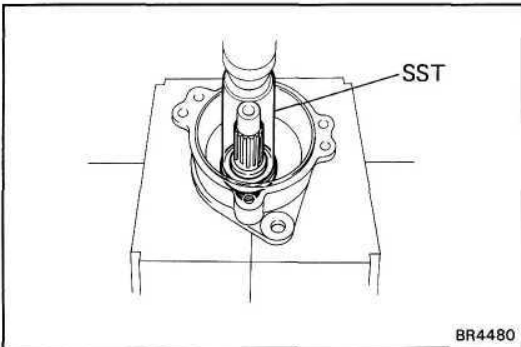

2. INSTALL ROTOR SHAFT

Using SST and press, install the rotor shaft to the casing.
SST 09608-30012 (09608-04030)

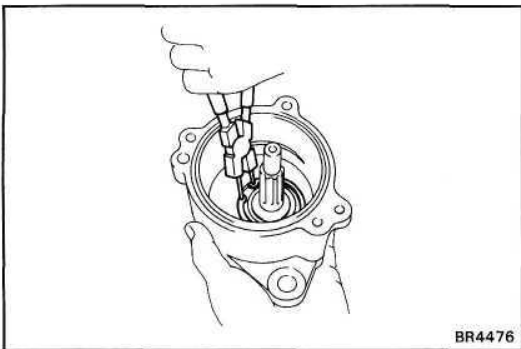

3. INSTALL SNAP RING

Using snap ring pliers, install the snap ring.

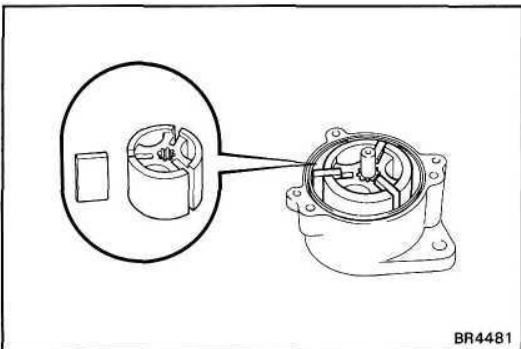

4. INSTALL ROTOR INTO CASING

Apply engine oil to the rotor and install it to the rotor shaft.

5. INSTALL THREE BLADES

- Apply engine oil to the blades.
- Install the three blades with the round end facing outward.
- Be sure that the blades and rotor surfaces are even.

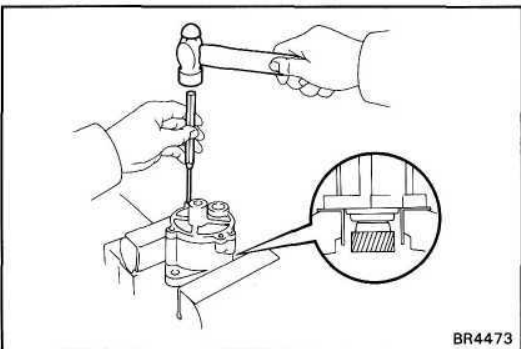

6. INSTALL END COVER

- Place the vacuum pump on vise as shown in the illustration.

NOTICE: Do not tighten the vise.

- Install the new O-ring.
- Install the end cover in place and temporarily install the three bolts.
- Using a pin punch and a hammer, drive in the two straight pins.

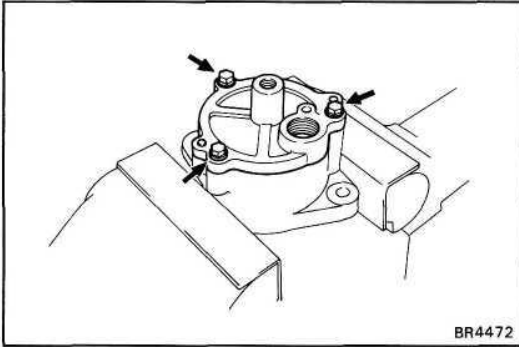

- (e) Using soft jaws on the vise, place the vacuum pump in the vise.

NOTICE: Do not tighten the vise too tightly.

- (f) Tighten the three bolts.

Torque: 80 kg-cm (69 in.-lb, 7.8 IM-m)

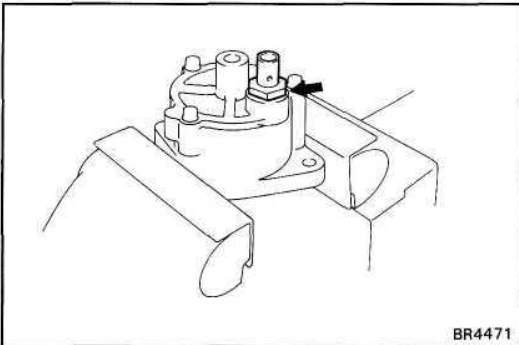

7. INSTALL CHECK VALVE

Install a new gasket and install the check valve.

Torque: 750 kg-cm (54 ft-lb, 74 N-m)

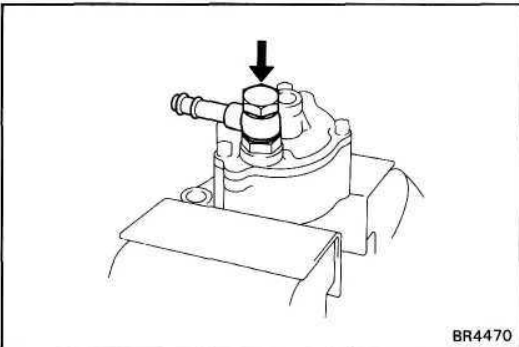

8. INSTALL VACUUM HOSE UNION

Install the vacuum hose union with the two new gaskets and, install and torque the union bolt.

Torque: 140 kg-cm (10 ft-lb, 14 N-m)

HINT: Align and insert the union pin into the matching portion of the casing.

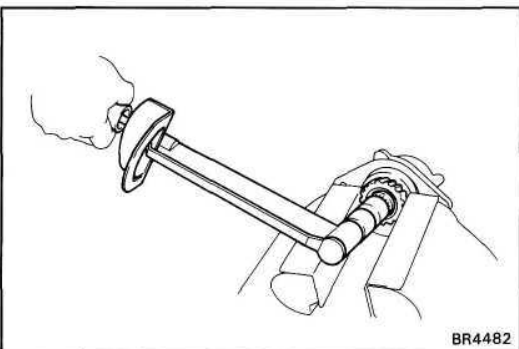

9. INSTALL GEAR

- (a) Temporarily install the woodruff key, gear and lock nut to the pump.

- (b) Using soft jaws on the vise, clamp the gear in the vise.

- (c) Tighten the gear lock nut.

Torque: 1,125 kg-cm (81 ft-lb, 110 N-m)

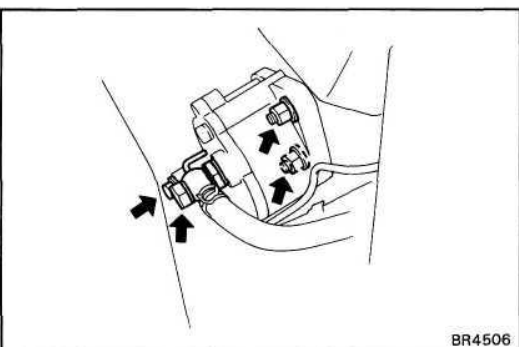

INSTALLATION OF VACUUM PUMP

INSTALL VACUUM PUMP

- (a) Install the new O-ring to the vacuum pump.

- (b) Install the vacuum pump in place and, install and tighten the two bolts.

Torque: 400 kg-cm (29 ft-lb, 39 N-m)

- (c) Set the oil tube and new gaskets in place and install the union bolt.

- (d) Using pliers, set the vacuum hoses in place.

FRONT BRAKE COMPONENTS

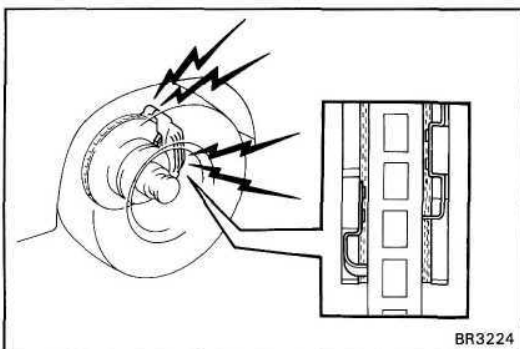
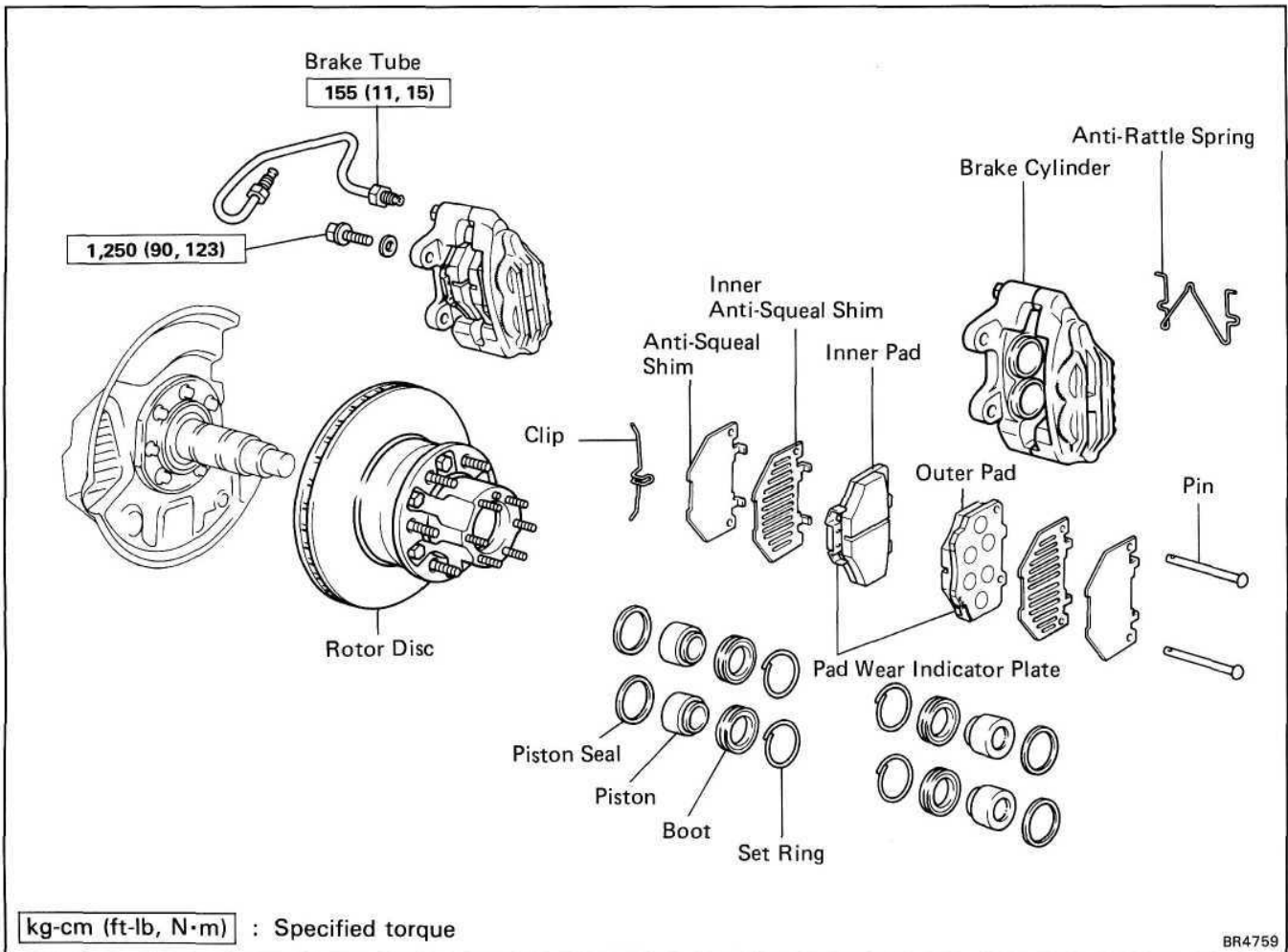

REPLACEMENT OF BRAKE PADS

HINT: If a squealing noise occurs from the brakes while driving, check the pad wear indicator plate. If the pad wear indicator plate contacts the rotor disc, the brake pads should be replaced.

1. REMOVE FRONT WHEEL

2. INSPECT PAD LINING THICKNESS

Check the pad thickness and replace pads if not within specification.

Minimum thickness:

Australia: 4.0 mm (0.157 in.)

Ex. Australia: 1.0 mm (0.039 in.)

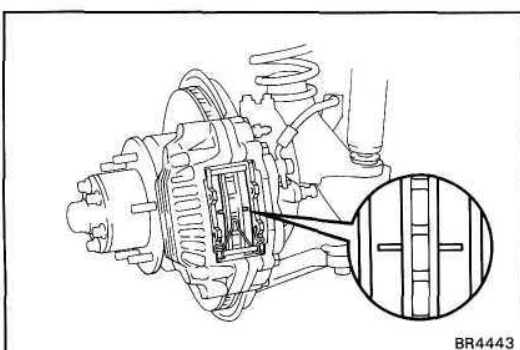

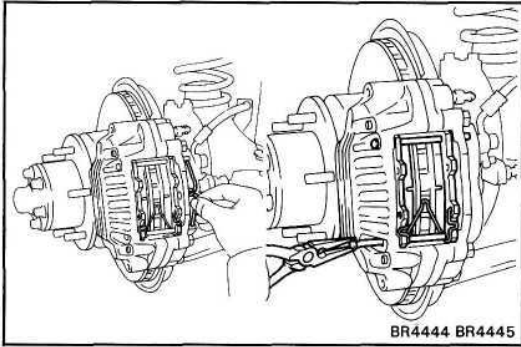

3. REMOVE FOLLOWING PARTS

- (a) Clip
- (b) Two pins

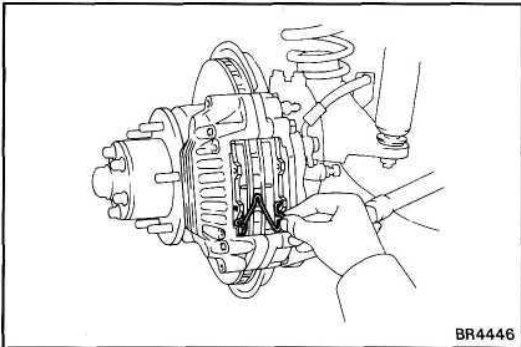

- (c) Anti-rattle spring
- (d) Two pins
- (e) Four anti-squeal shims

4. CHECK ROTOR DISC THICKNESS
(See step 2 on page BR-38)

5. CHECK ROTOR DISC RUNOUT
(See step 3 on page BR-38)

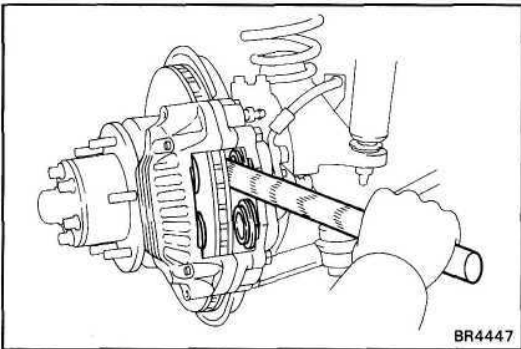

6. INSTALL NEW PADS

- (a) Draw out a small amount of brake fluid from the reservoir.
- (b) Press in the pistons with a hammer handle or an equivalent.

HINT: Always change the pads on one wheel at a time as there is possibility of the opposite piston flying out.

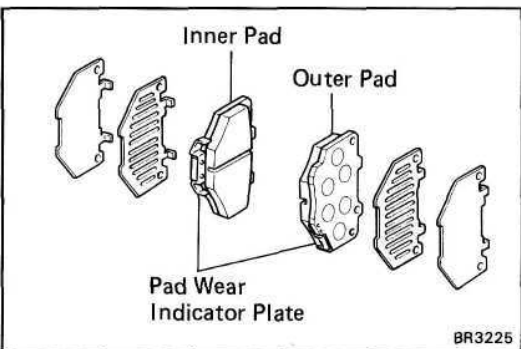

- (c) Install the four anti-squeal shims to new pads as shown.

HINT: Apply disc brake grease to both sides of the inner anti-squeal shims.

- (d) Install the two pads into the cylinder.

NOTICE: Do not allow oil or grease to get on the rubbing face.

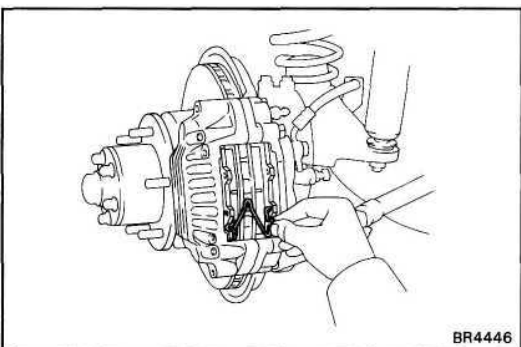

7. INSTALL ANTI-RATTLE SPRING

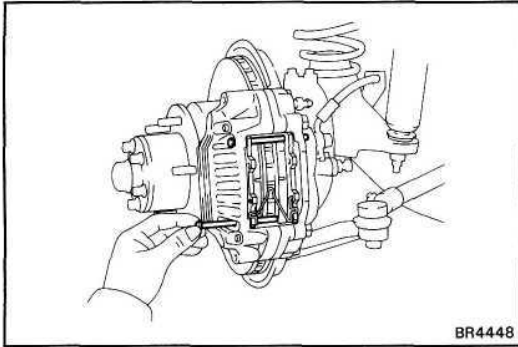

8. INSTALL TWO PINS

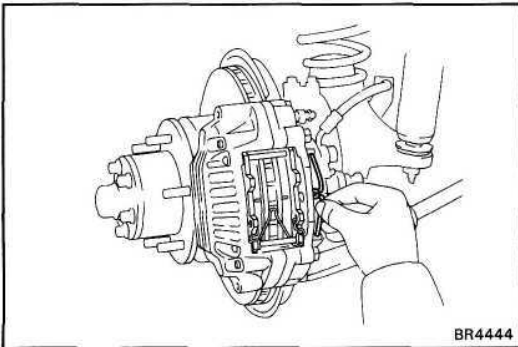

9. INSTALL CLIP

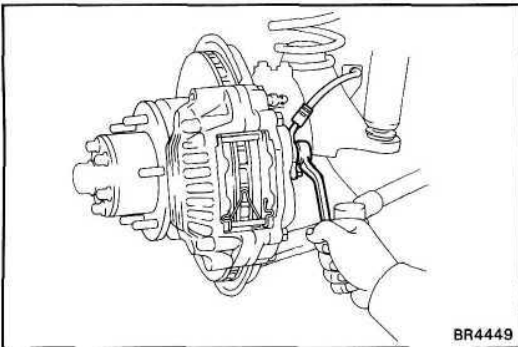

REMOVAL OF CYLINDER

(See page BR-34)

1. REMOVE FRONT WHEEL

2. DISCONNECT BRAKE LINE

Disconnect the brake hose. Use a container to catch the brake fluid.

3. REMOVE CYLINDER

Remove the two mounting bolts and remove the cylinder.

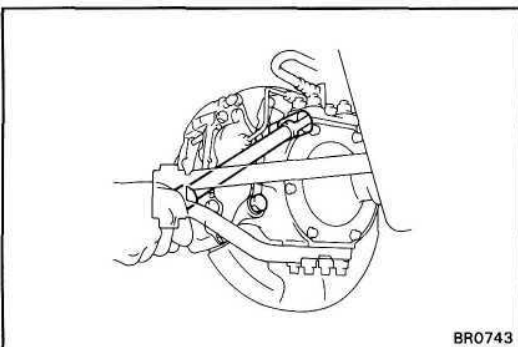

4. REMOVE FOLLOWING PARTS

- (a) Clip
- (b) Two pins
- (c) Anti-rattle spring
- (d) Two pads
- (e) Four anti-squeal shims

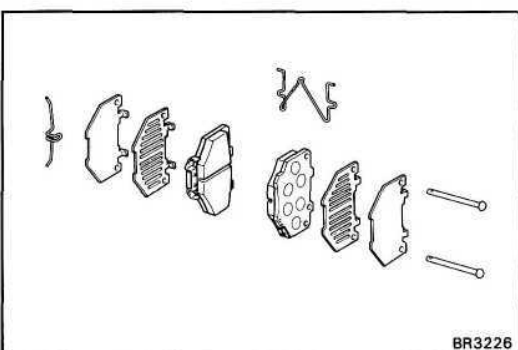

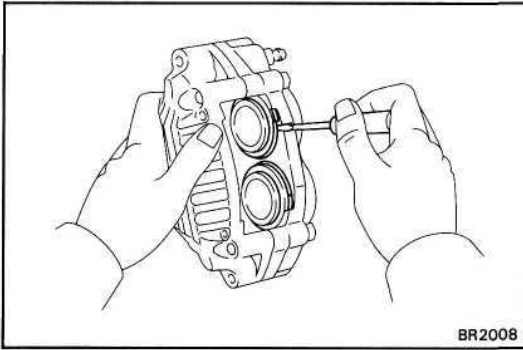

DISASSEMBLY OF CYLINDER

(See page BR-34)

1. REMOVE CYLINDER BOOT SET RINGS AND BOOTS

Using a screwdriver, remove the four cylinder boot set rings and four boots.

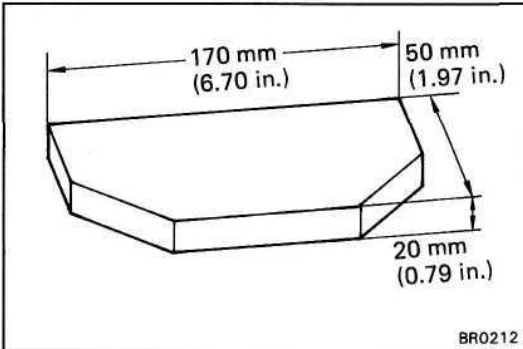

2. REMOVE PISTONS FROM CYLINDER

(a) Prepare the wooden plate as shown in the illustration to hold the pistons.

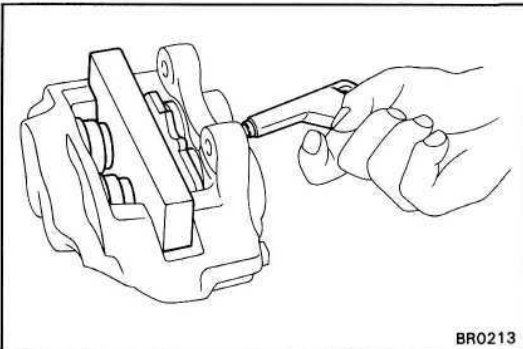

(b) Place the plate between the pistons and insert a pad at one side.

(c) Use compressed air to remove the pistons alternately from the cylinder.

NOTICE: Do not place your fingers in front of the pistons when using compressed air.

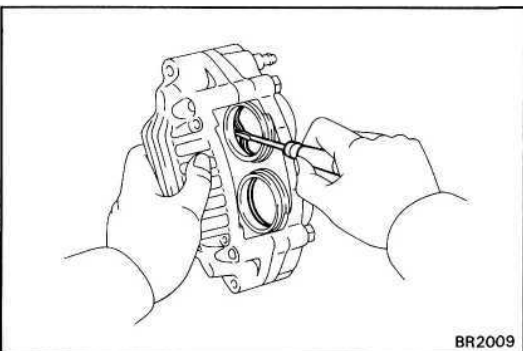

3. REMOVE PISTON SEALS

Using a screwdriver, remove the four seals from the cylinder.

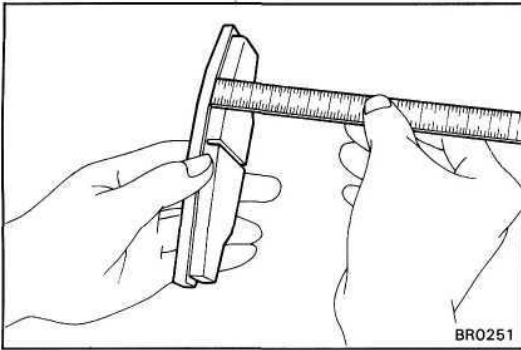

INSPECTION AND REPAIR OF FRONT BRAKE COMPONENTS

1. MEASURE PAD LINING THICKNESS

Minimum thickness:

Australia: 4.0 mm (0.157 in.)

Except Australia: 1.0 mm (0.039 in.)

Standard thickness: 10.0 mm (0.394 in.)

Replace the pads if the thickness is less than the minimum or if it shows sign of uneven wear.

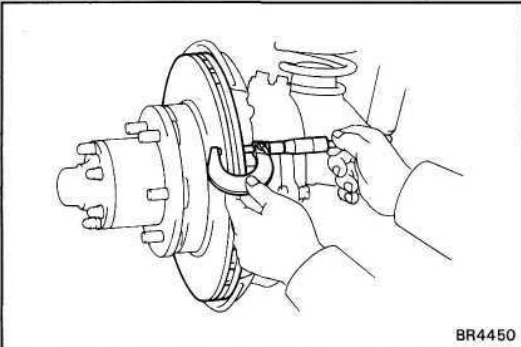

2. MEASURE ROTOR DISC THICKNESS

Minimum thickness: 23.0 mm (0.906 in.)

Standard thickness: 25.0 mm (0.984 in.)

If the disc is scored or worn, or if thickness is less than minimum, repair or replace the disc.

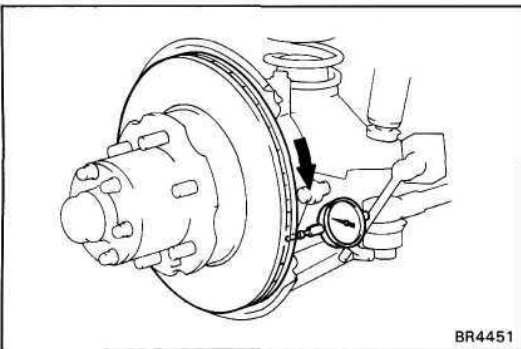

3. MEASURE ROTOR DISC RUNOUT

Measure the rotor disc runout at 10 mm (0.39 in.) from the outer edge of the rotor disc.

Maximum disc runout: 0.15 mm (0.0059 in.)

If the runout is greater than maximum, replace the rotor disc.

HINT: Before measuring the runout, confirm that the front bearing play is within specification.

4. IF NECESSARY, REPLACE ROTOR DISC

(a) Remove the front axle hub.
(See page SA-15)

(b) Remove the disc from the axle hub.

(c) Install a new rotor disc and torque the bolts.

Torque: 750 kg-cm (54 ft-lb, 74 N-m)

(d) Install the axle hub and adjust the front bearing preload.
(See page SA-19)

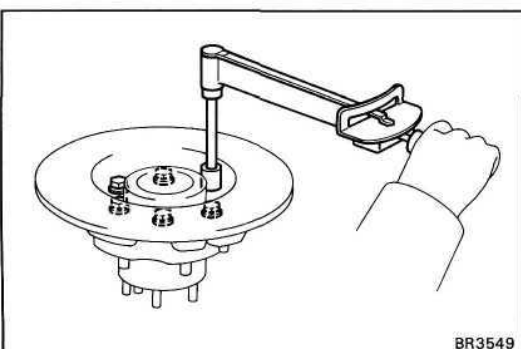

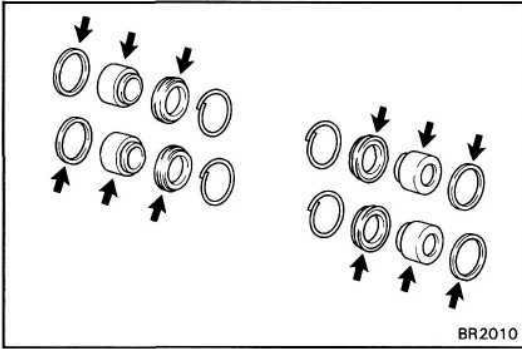

ASSEMBLY OF CYLINDER

(See page BR-34)

1. APPLY LITHIUM SOAP BASE GLYCOL GREASE TO PARTS INDICATED BY ARROWS

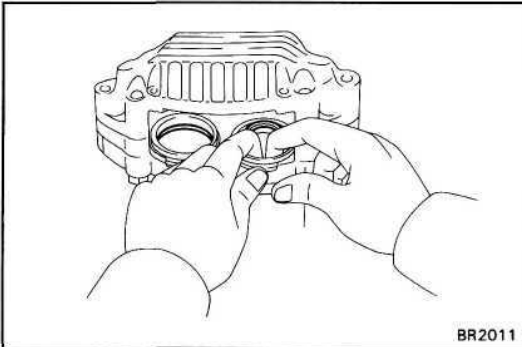

2. INSTALL PISTON SEALS INTO CYLINDER

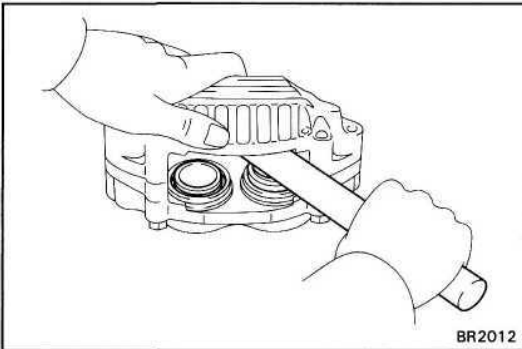

3. INSTALL PISTONS INTO CYLINDER

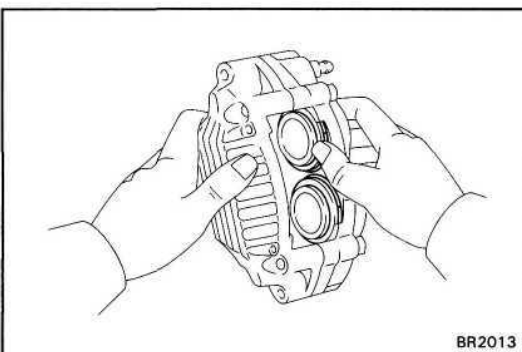

4. INSTALL CYLINDER BOOTS AND SET RINGS INTO CYLINDER

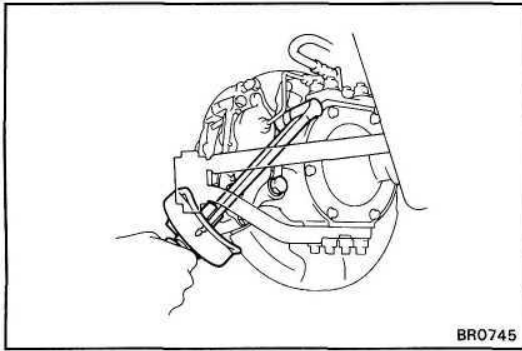

INSTALLATION OF CYLINDER

(See page BR-34)

1. INSTALL CYLINDER

Install the brake cylinder, and torque the two mounting bolts.

Torque: 1,250 kg-cm (90 ft-lb, 123 N-m)

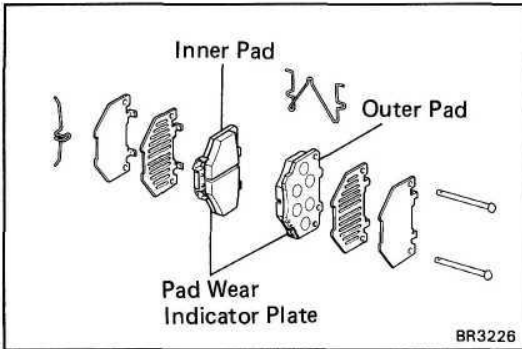

2. INSTALL PADS

(See steps 4 to 5 on pages BR-35 and 36)

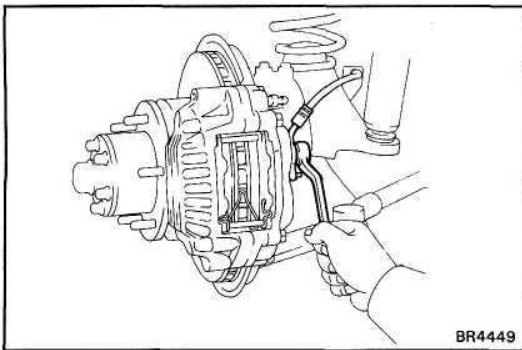

3. INSTALL BRAKE TUBE

Using SST, connect the brake tube.

Torque: 235 kg-cm (17 ft-lb. 23 N-m)

4. FILL BRAKE RESERVOIR WITH BRAKE FLUID AND BLEED BRAKE SYSTEM

(See page BR-7)

5. CHECK FOR FLUID LEAKAGE

6. INSTALL FRONT WHEEL

REAR BRAKE

Drum Brake

COMPONENTS

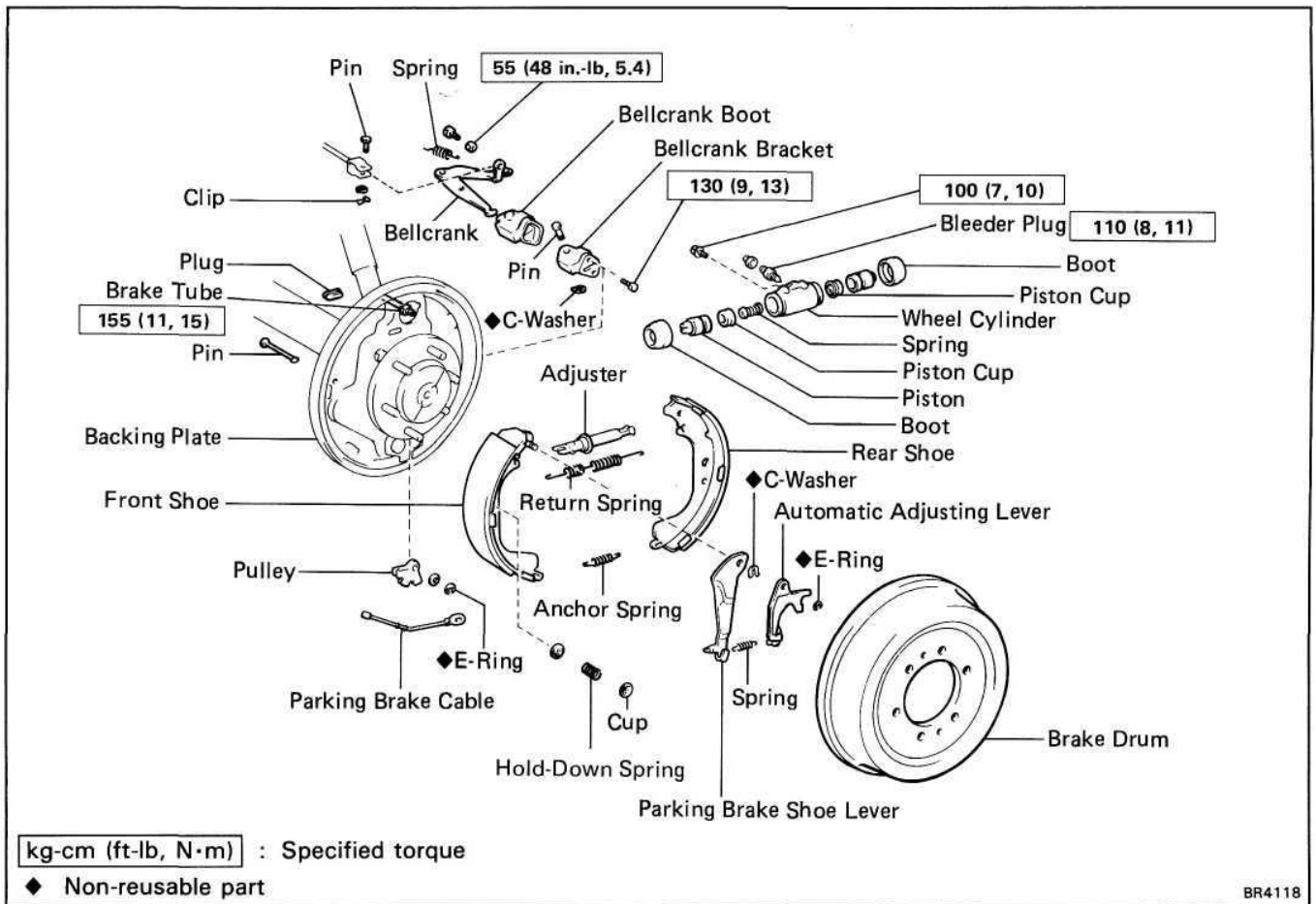

BR4118

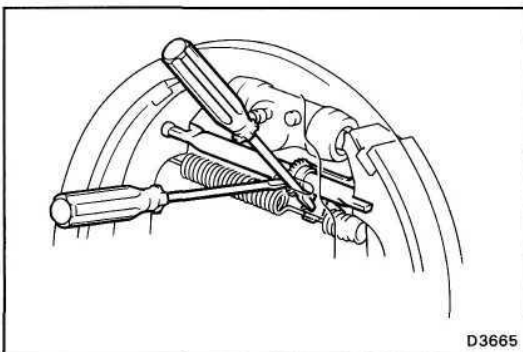

REMOVAL OF REAR BRAKE

1. REMOVE REAR WHEEL AND BRAKE DRUM

HINT: If the brake drum cannot be removed easily, perform the following steps.

- Insert a screwdriver through the hole in the backing plate, and hold the automatic adjusting lever away from the adjusting bolt.
- Using another screwdriver, reduce the brake shoe adjustment by turning the adjusting bolt.

2. REMOVE REAR SHOE

- Using SST, remove the return spring.
SST 09703-30010

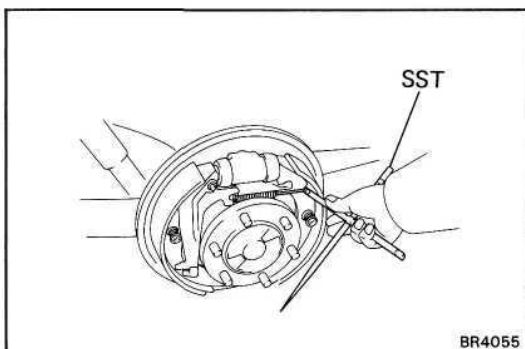

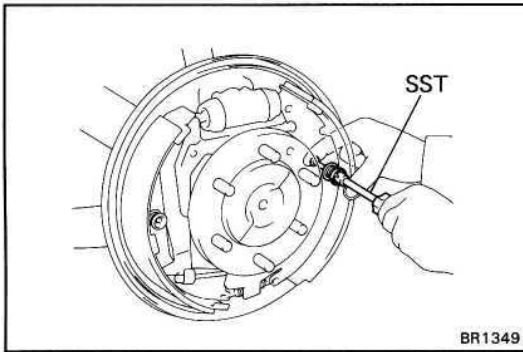

- (b) Using SST, remove the two cups, shoe hold-down spring and a pin.

SST 09718-00010

- (c) Remove the rear brake shoe and anchor spring.

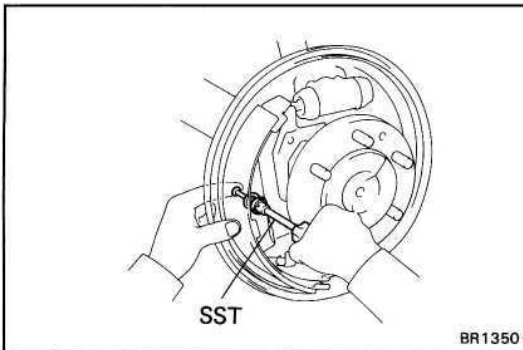

3. REMOVE FRONT SHOE

- (a) Using SST, remove the two cups, shoe hold-down spring and a pin.

SST 09718-00010

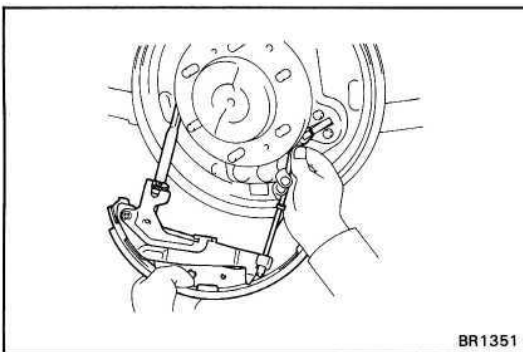

- (b) Disconnect the parking brake cable from the parking brake bellcrank.

- (c) Remove the front shoe with adjuster.

- (d) Disconnect the parking brake cable from the front shoe.

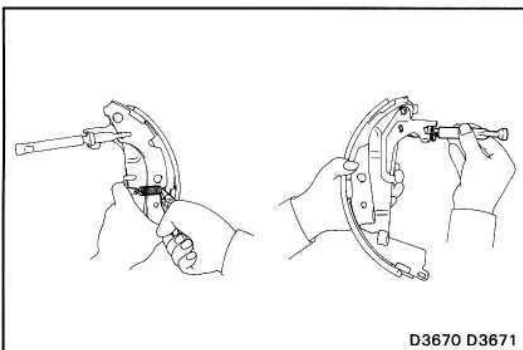

4. REMOVE ADJUSTER FROM FRONT SHOE

- (a) Remove the adjusting lever spring.

- (b) Remove the adjuster.

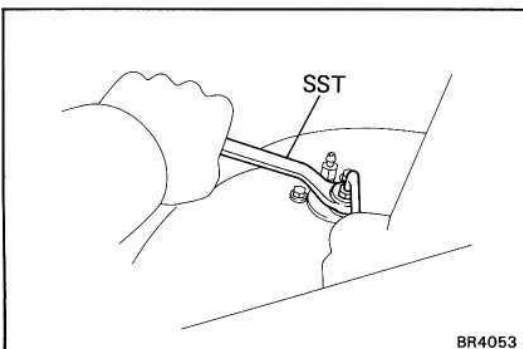

5. IF NECESSARY, REMOVE WHEEL CYLINDER

- (a) Using SST, disconnect the brake tube.

SST 09751-36011

- (b) Remove the two bolts and the wheel cylinder.

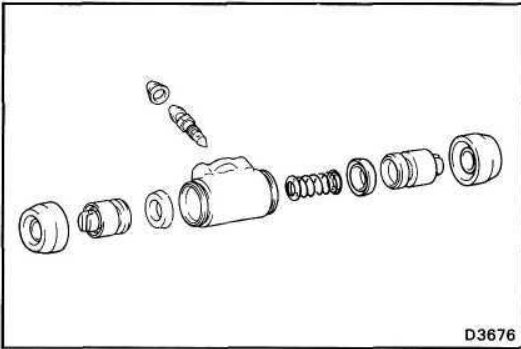

6. DISASSEMBLE WHEEL CYLINDER

Remove the following parts from the wheel cylinder.

- Two boots
- Two pistons
- Two piston cups
- Spring

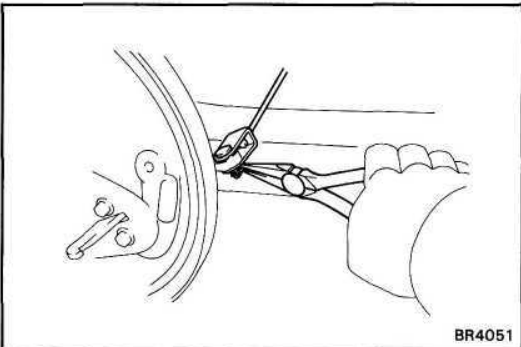

7. IF NECESSARY, REMOVE AND DISASSEMBLE PARKING BRAKE BELLCRANK ASSEMBLY

- (a) Remove the clip.
- (b) Remove the pin and wave washer, then disconnect the parking brake cable.

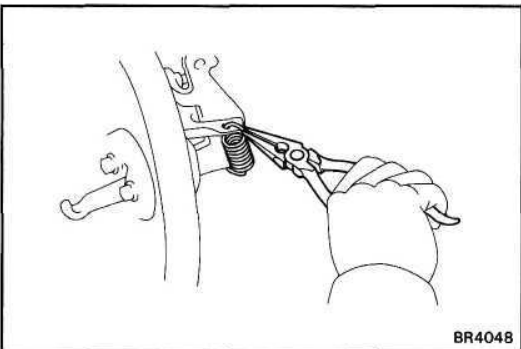

- (c) Remove the two tension springs.

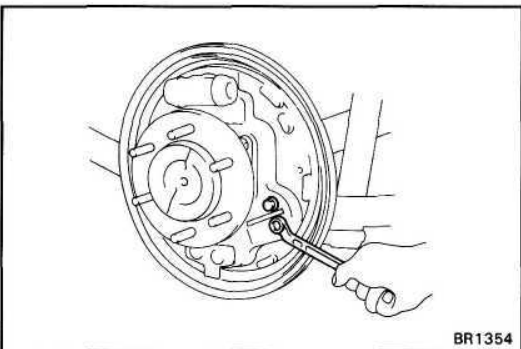

- (d) Remove the two bolts and parking brake bellcrank assembly.

- (e) Remove the boot from the parking brake bellcrank bracket.

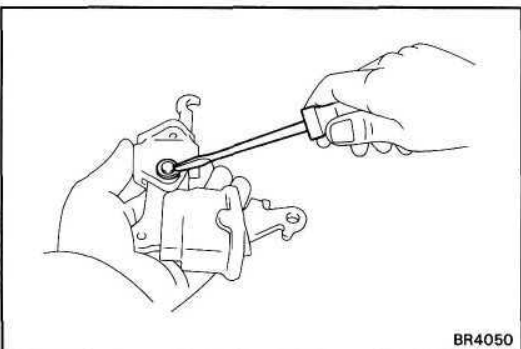

- (f) Using a screwdriver, remove the C-washer and pin.

- (g) Remove the parking brake bellcrank from the crank bracket.

- (h) Remove the boot.

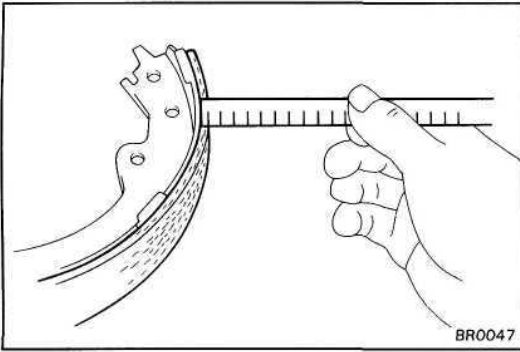

INSPECTION OF REAR BRAKE COMPONENTS

1. MEASURE BRAKE SHOE LINING THICKNESS

Minimum thickness: 1.5 mm (0.059 in.)

Standard thickness: 6.5 mm (0.265 in.)

If the shoe lining is less than minimum or shows signs of uneven wear, replace the brake shoes.

HINT: If any of the brake shoes have to be replaced, replace all of the brake shoes in order to maintain even braking.

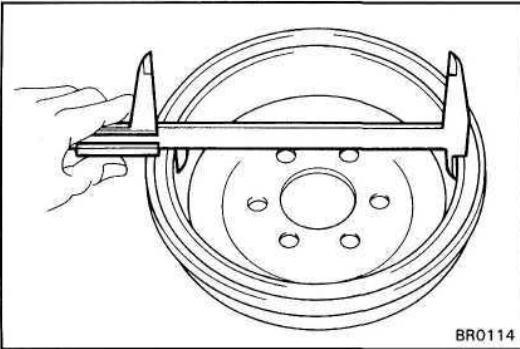

2. MEASURE BRAKE DRUM INSIDE DIAMETER

Maximum inside diameter: 297.0 mm (11.693 in.)

Standard inside diameter: 295.0 mm (11.614 in.)

If the drum is scoured or worn, the brake drum may be lathed to the maximum inside diameter.

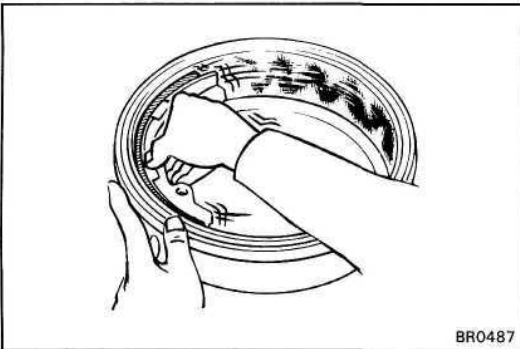

3. INSPECT BRAKE LINING AND DRUM FOR PROPER CONTACT

If the contact between the brake lining and drum is improper, repair the lining with a brake shoe grinder, or replace the brake shoe assembly.

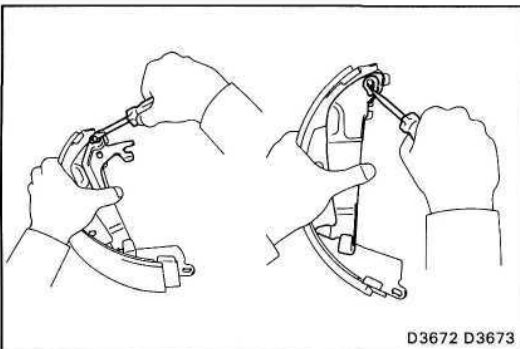

4. IF NECESSARY, REPLACE BRAKE SHOES

(a) Using a screwdriver, remove the automatic adjusting lever from the front shoe.

(b) Using a screwdriver, remove the parking brake shoe lever from the front shoe.

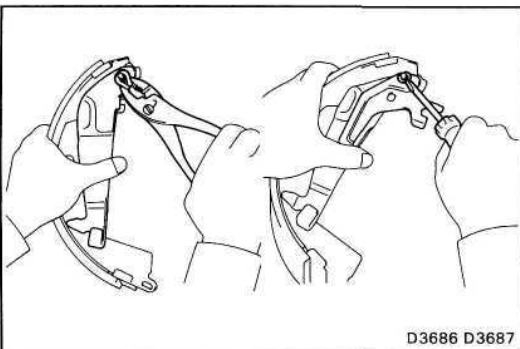

(c) Using pliers, install the parking brake shoe lever with a new C-washer.

(d) Install the automatic adjusting lever with a new E-ring.

5. INSPECT WHEEL CYLINDER FOR CORROSION OR DAMAGE

6. INSPECT BACKING PLATE FOR WEAR OR DAMAGE

7. INSPECT BELLCRANK PARTS FOR BENDING, WEAR OR DAMAGE

ASSEMBLY OF REAR BRAKE

(See page BR-41)

HINT: Assemble the parts in the correct direction as shown below.

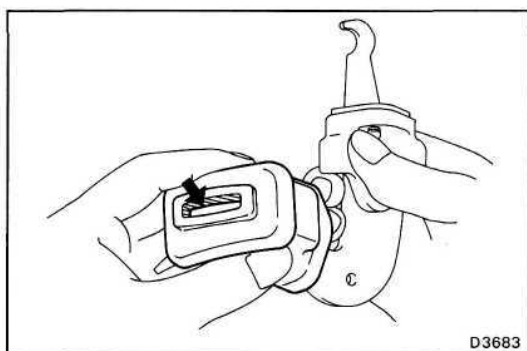
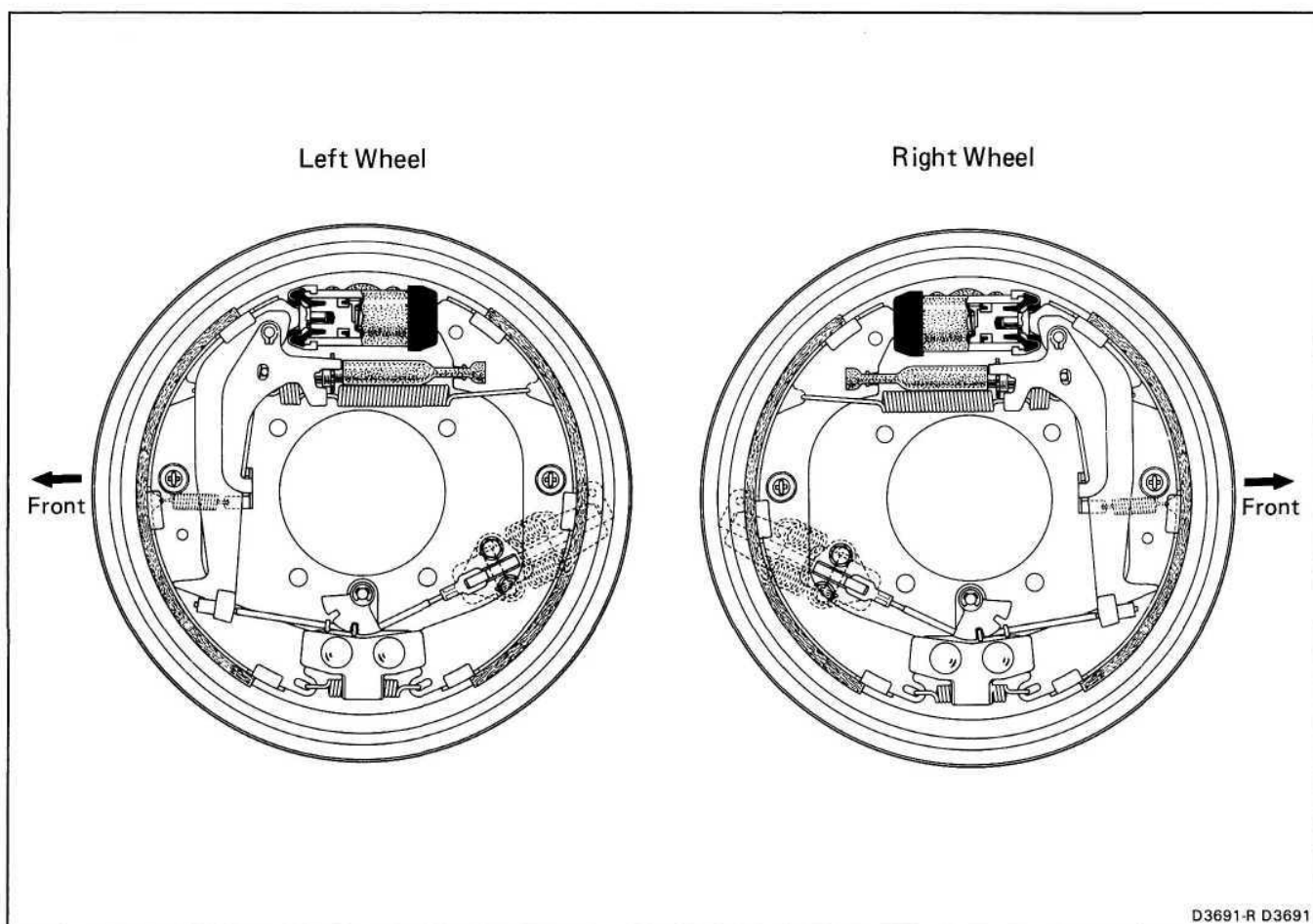

1. **IF NECESSARY, ASSEMBLE AND INSTALL PARKING BRAKE BELLCRANK ASSEMBLY**

- (a) Apply lithium soap base glycol grease to the boot.
- (b) Install the boot to the parking brake bellcrank.

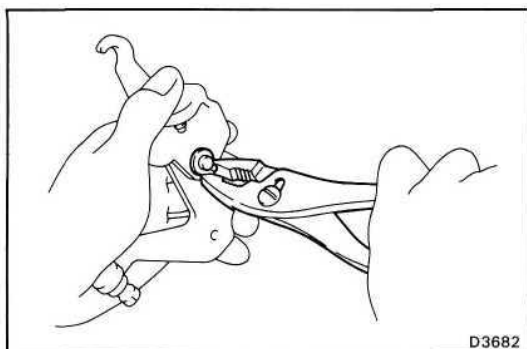

- (c) Install the parking brake bellcrank to the bellcrank bracket.
- (d) Install the pin with a new C-washer.

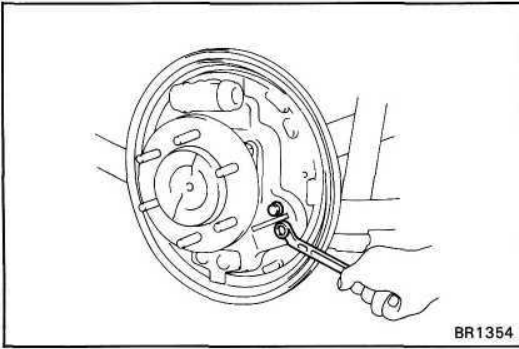

- (e) Install the parking brake bellcrank assembly on the backing plate with two bolts.
- (f) Torque the bolts.

Torque: 130 kg-cm (9 ft-lb, 13 N-m)

- (g) Connect the parking brake cable to the bellcrank assembly with the pin, wave washer and clip.

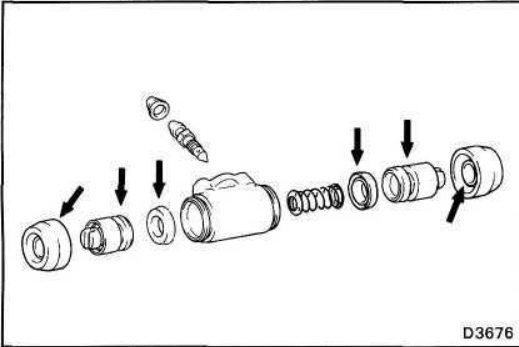

2. IF NECESSARY, ASSEMBLE AND INSTALL WHEEL CYLINDER

- (a) Apply lithium soap base glycol grease to the piston cups, boots and pistons.

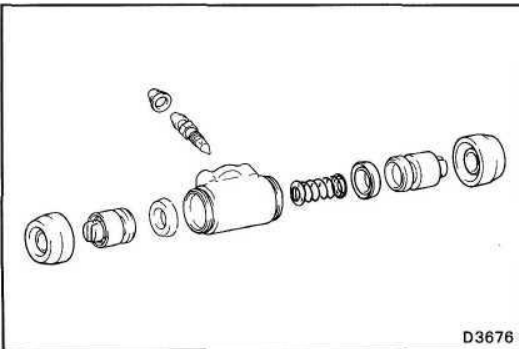

- (b) Install the spring and two piston cups into the wheel cylinder.

HINT: Make sure the flanges of the cups are pointed inward.

- (c) Install the two pistons, boots into the cylinder.

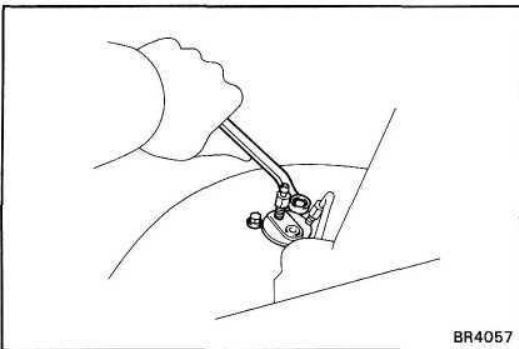

- (d) Install the wheel cylinder on the backing plate with two bolts.

Torque: 100 kg-cm (7 ft-lb, 10 N-m)

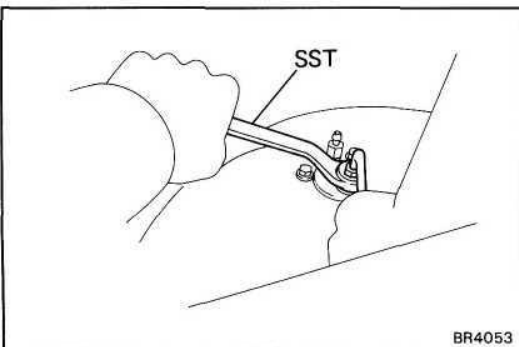

- (e) Using SST, connect the brake tube.
SST 09751-36011

Torque: 155 kg-cm (11 ft-lb, 15 N-m)

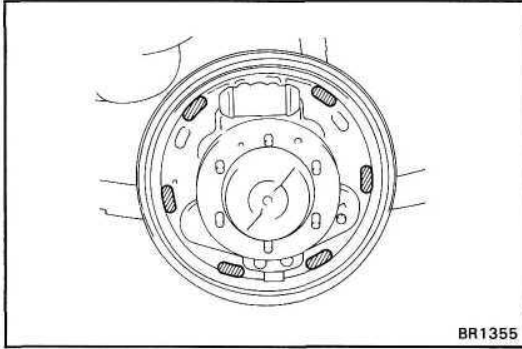

3. APPLY HIGH TEMPERATURE GREASE TO BACKING PLATE AS SHOWN

Apply high temperature grease to the sliding surfaces of the shoe.

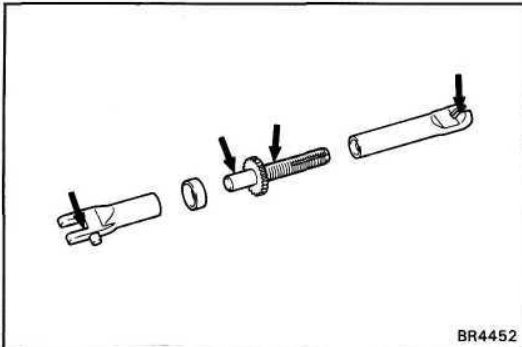

4. APPLY HIGH TEMPERATURE GREASE TO ADJUSTER

Apply high temperature grease to the adjuster bolt threads and ends.

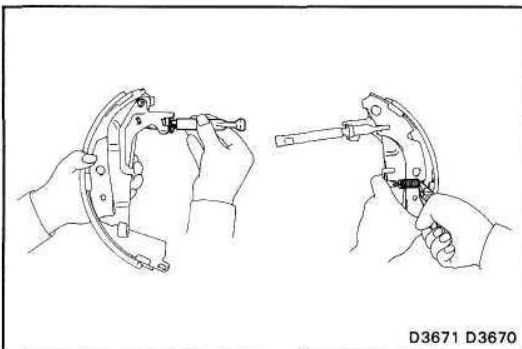

5. INSTALL ADJUSTER TO FRONT SHOE

- (a) Install the adjuster to the adjusting lever.
- (b) Install the adjusting lever spring.

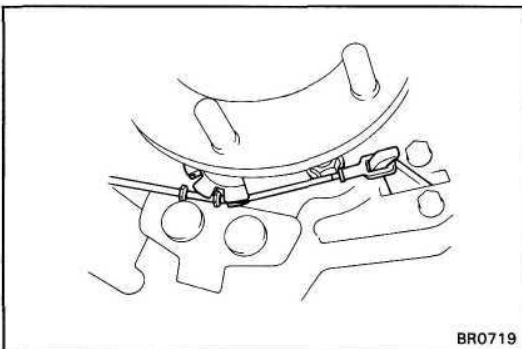

6. INSTALL FRONT SHOE

- (a) Install the parking brake cable to the parking brake shoe lever.
- (b) Install the parking cable to the bellcrank as shown.

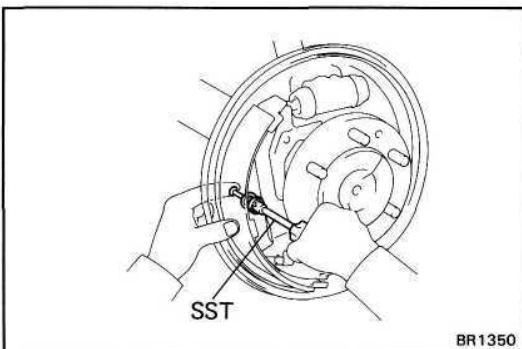

- (c) Set the front shoe in place with the end of the shoe inserted in the piston.
- (d) Using SST, install the shoe hold-down spring, two cups and a pin.

SST 09718-00010

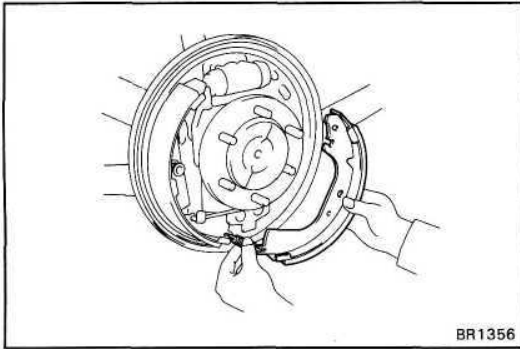

7. INSTALL REAR SHOE

- (a) Install the anchor spring between the front shoe and rear shoe.

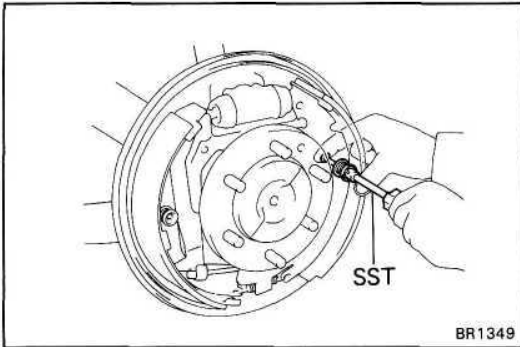

- (b) Set the rear shoe in place with the end of the shoe inserted in the piston.
- (c) Using SST, install the shoe hold-down spring, two cups and a pin.

SST 09718-00010

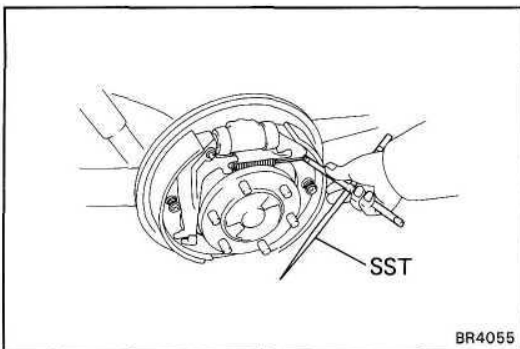

- (d) Using SST, install the return spring.

SST 09703-30010

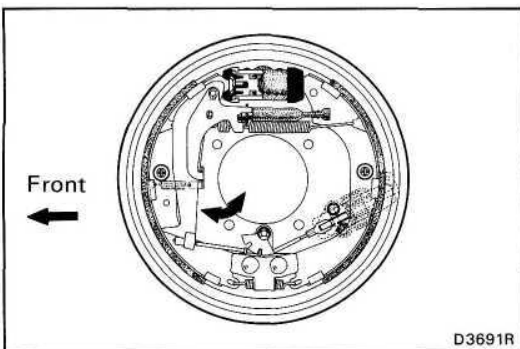

8. CHECK OPERATION OF AUTOMATIC ADJUSTER MECHANISM

- (a) Pull the parking brake cable backward as shown, and release. Check that the adjusting bolt turns.

If the bolt does not turn, check for incorrect installation of the rear brakes.

- (b) Adjust the adjuster to the shortest possible length.
- (c) Install the drum.
- (d) Connect the No. 2 parking brake cable to the bellcrank.

- (e) Pull the parking brake lever all the way up and down until a clicking sound can no longer be heard.

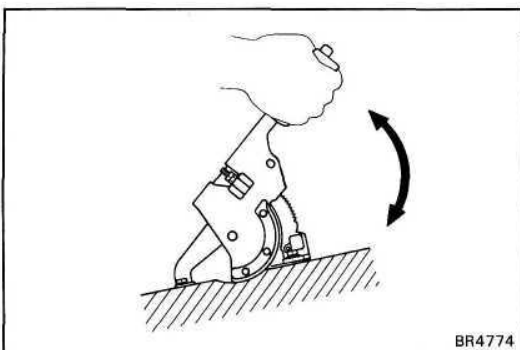

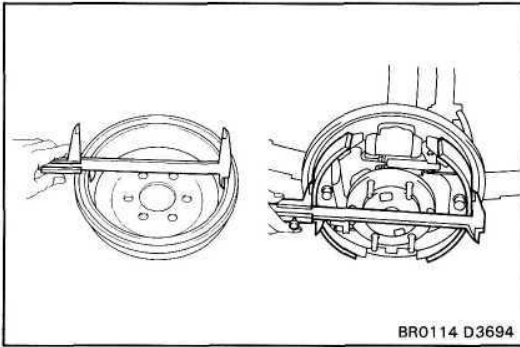

9. CHECK CLEARANCE BETWEEN BRAKE SHOES AND DRUM

- (a) Remove the brake drum.
- (b) Measure the brake drum inside diameter and diameter of the brake shoes. Check that the difference between the diameter is correct shoe clearance.

Shoe clearance: 0.6 mm (0.024 in.)

If incorrect, check the parking brake system.

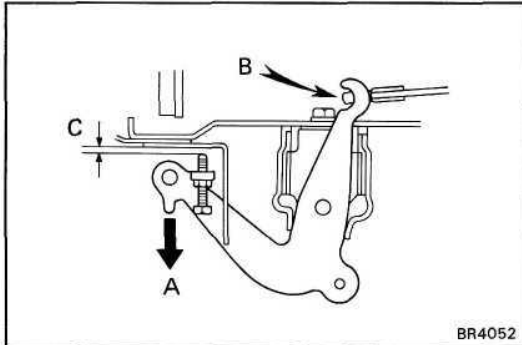

10. IF NECESSARY, ADJUST BELLCRANK

- (a) Lightly pull the bellcrank in direction A until there is no slack at part B.
- (b) In this condition, turn the adjusting bolt so that dimension C will be 0.4 - 0.8 mm (0.016 - 0.031 in.).
- (c) Lock the adjust bolt with the lock nut.

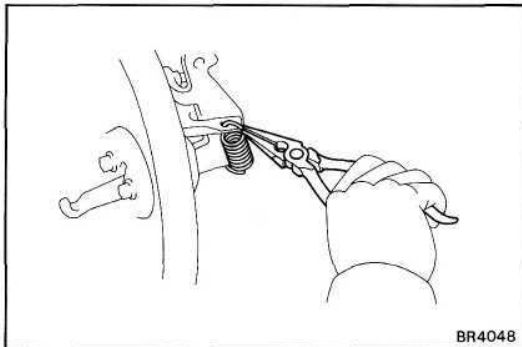

- (d) Install the two tension springs.

11. INSTALL BRAKE DRUM AND REAR WHEEL

12. FILL BRAKE RESERVOIR WITH BRAKE FLUID AND BLEED BRAKE SYSTEM

(See page BR-7)

13. CHECK FOR FLUID LEAKAGE

Disc Brake COMPONENTS

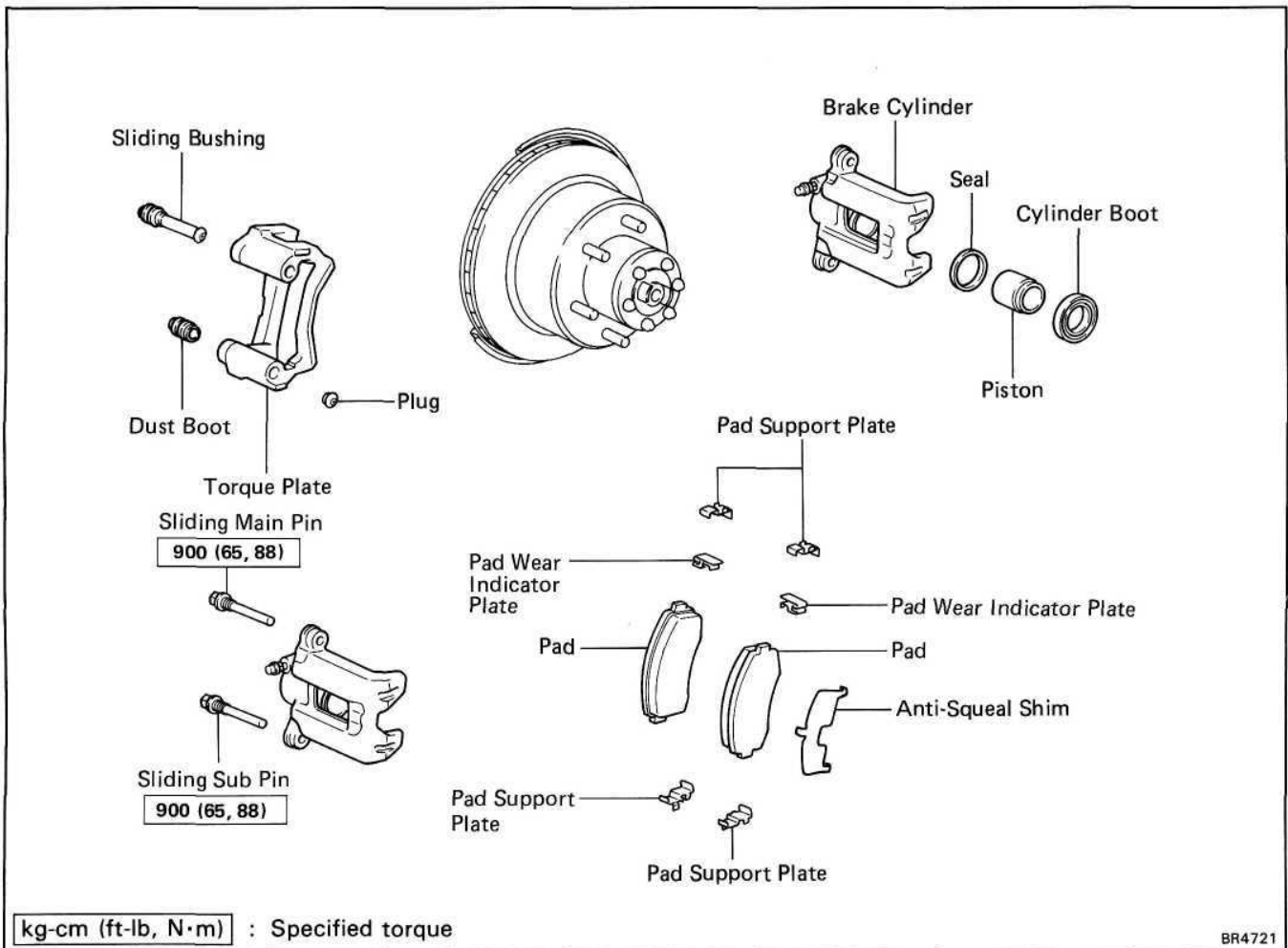

BR4721

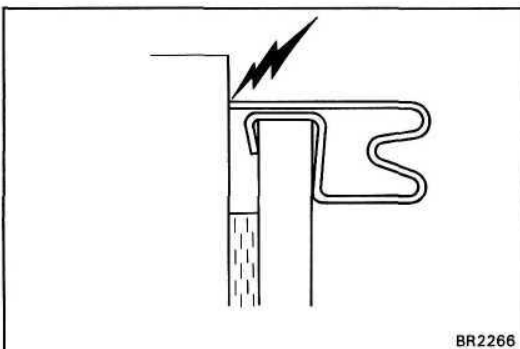

BR2266

REPLACEMENT OF BRAKE PADS

HINT: If a squealing noise occurs from the brakes while driving, check the pad wear indicator plate. If the pad wear indicator plate contacts the rotor disc, the brake pads should be replaced.

1. REMOVE REAR WHEEL

2. INSPECT PAD LINING THICKNESS

Check the pad thickness through the cylinder inspection hole and replace pads if not within specification.

Minimum thickness: 1.0 mm (0.039 in.)

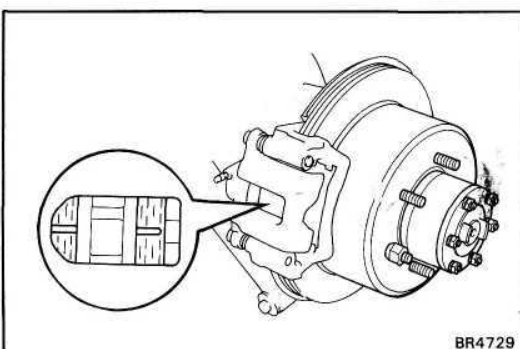

BR4729

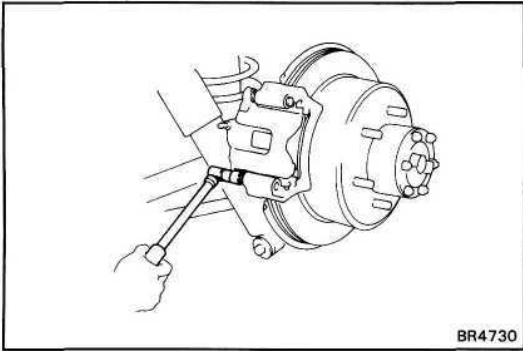

3. REMOVE BRAKE CYLINDER

- (a) Remove the sliding main pin and sliding sub pin.

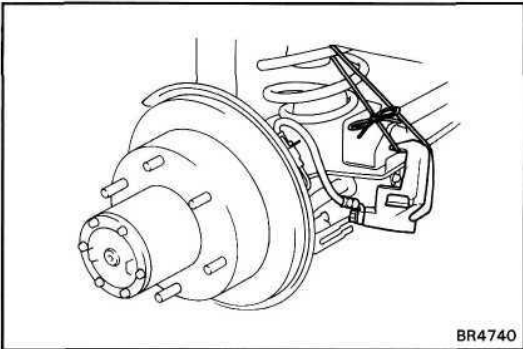

- (b) Remove the brake cylinder and suspend it so the hose is not stretched.

HINT: Do not disconnect the brake hose.

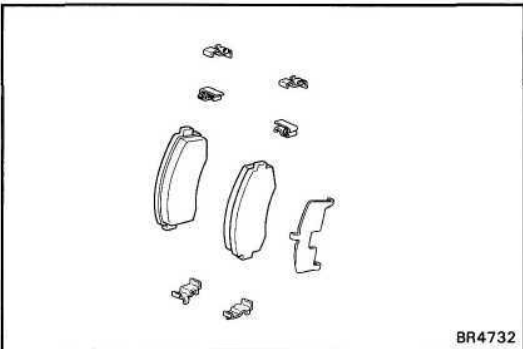

4. REMOVE FOLLOWING PARTS

- (a) Two brake pads
 (b) Anti-squeal shim
 (c) Two pad wear indicator plates
 (d) Four pad support plates

5. CHECK ROTOR DISC THICKNESS (See step 2 on page BR-54)

6. CHECK ROTOR DISC RUNOUT (See step 3 on page BR-54)

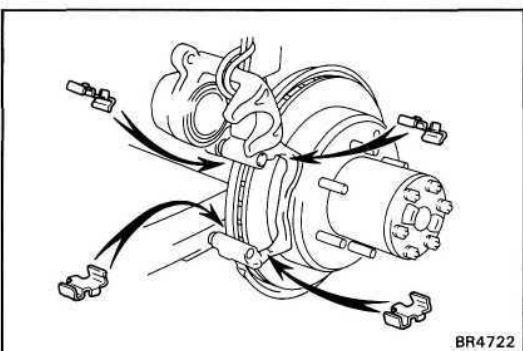

7. INSTALL PAD SUPPORT PLATES

Install the four pad support plates.

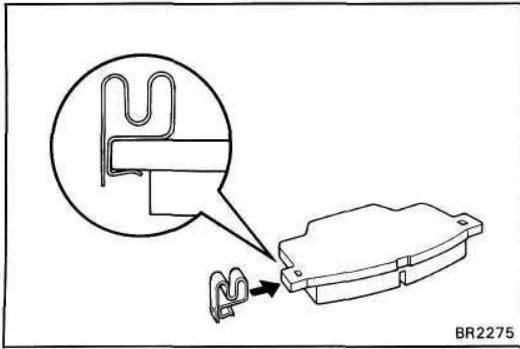

BR2275

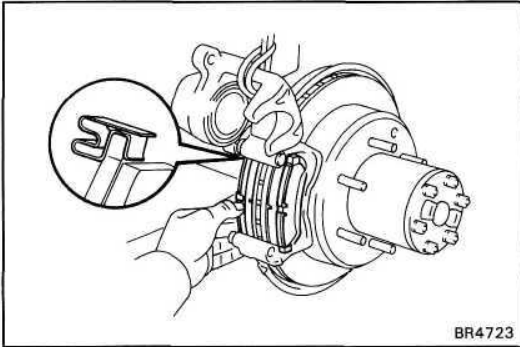

BR4723

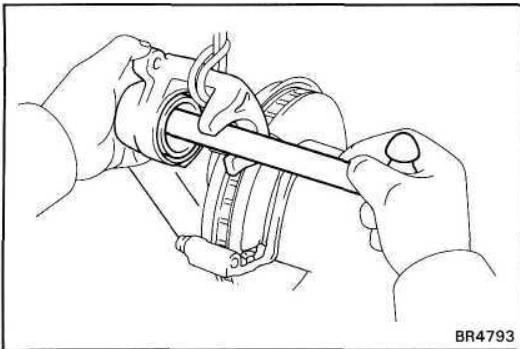

BR4793

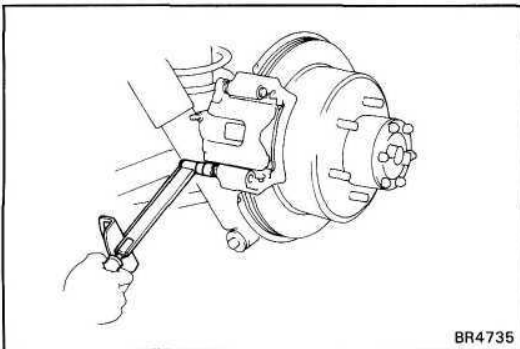

BR4735

8. INSTALL NEW PADS

- (a) Install pad wear indicator plate to each pads.
- (b) Install the two anti-squeal shims to the each pads.

- (c) Install the two pads so the wear indicator plate is facing upward.

NOTICE: Do not allow oil or grease to get on the rubbing face.

9. INSTALL CYLINDER

- (a) Draw out a small amount of brake fluid from reservoir.
- (b) Press in piston with a hammer handle or an equivalent.

HINT: Always change the pads on one wheel at a time as there is a possibility of the opposite piston flying out.

- (c) Install the brake cylinder carefully so the boot is not wedged.

- (d) Install and torque the sliding main pin and sub pin.

Torque: 900 kg-cm (65 ft-lb, 88 N-m)

10. INSTALL REAR WHEEL

11. FILL BRAKE FLUID

REMOVAL OF CYLINDER

(See page BR-50)

1. DISCONNECT BRAKE HOSE

Remove the union bolt and disconnect the brake hose.
Use a container to catch the brake fluid.

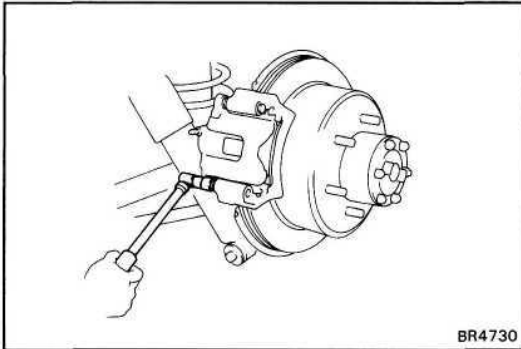
**2. REMOVE CYLINDER FROM TORQUE PLATE**

Remove the two sliding pins and cylinder.

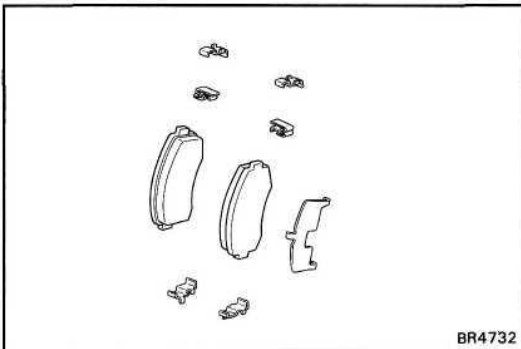
**3. REMOVE PADS**

(See step 3 on page BR-51)

DISASSEMBLY OF CYLINDER

(See page BR-50)

1. REMOVE PISTON FROM CYLINDER

- (a) Put a piece of cloth or equivalent between the piston and cylinder.
- (b) Use compressed air to remove the piston and cylinder boot from the cylinder.

NOTICE: Do not place your fingers in front of the piston when using compressed air.

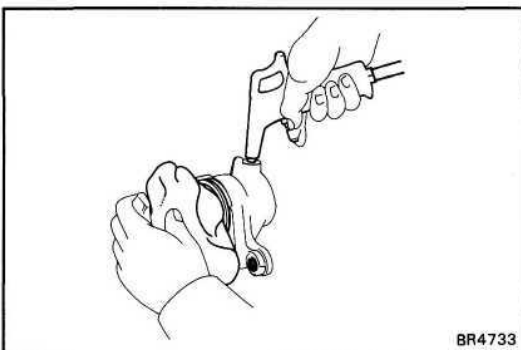
**2. REMOVE PISTON SEAL FROM BRAKE CYLINDER**

Using a screwdriver, remove the piston seal.

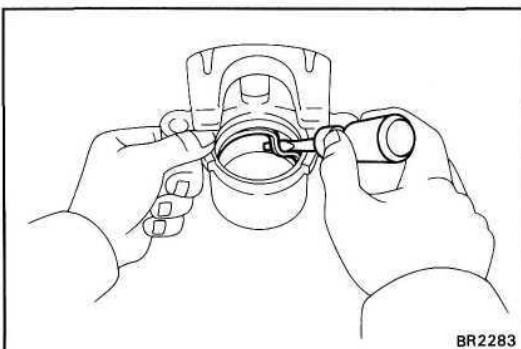

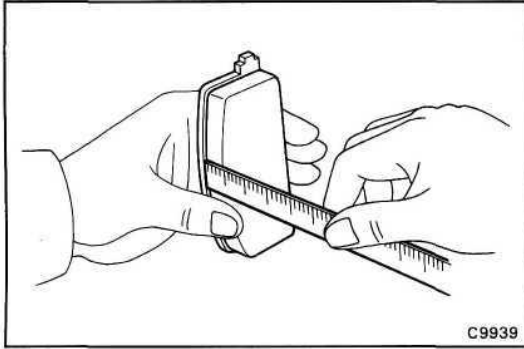

INSPECTION AND REPAIR OF REAR BRAKE COMPONENTS

1. MEASURE PAD LINING THICKNESS

Minimum thickness: 1.0 mm (0.039 in.)

Standard thickness: 10.0 mm (0.394 in.)

Replace the pad if the thickness is less than the minimum or if it shows sign of uneven wear.

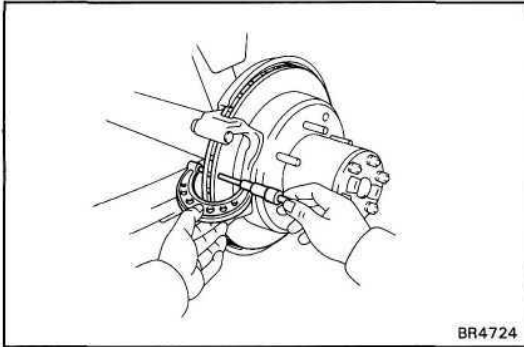

2. MEASURE ROTOR DISC THICKNESS

Minimum thickness: 16.0 mm (0.630 in.)

Standard thickness: 18.0 mm (0.709 in.)

If the disc is scored or worn, or if thickness is less than minimum, or replace the disc.

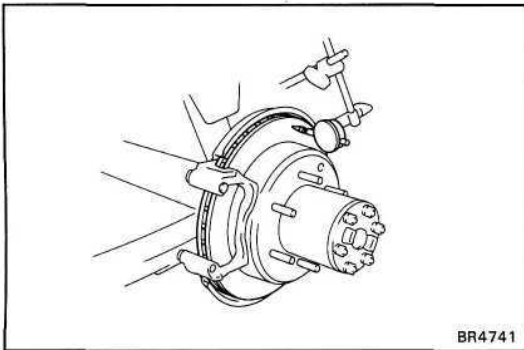

3. MEASURE ROTOR DISC RUNOUT

Measure the rotor disc runout at 10 mm (0.39 in.) from the outer edge of rotor disc.

Maximum disc runout: 0.15 mm (0.0059 in.)

If the runout is greater than maximum, replace the disc.

HINT: Before measuring the runout, confirm that the front bearing play is within specification.

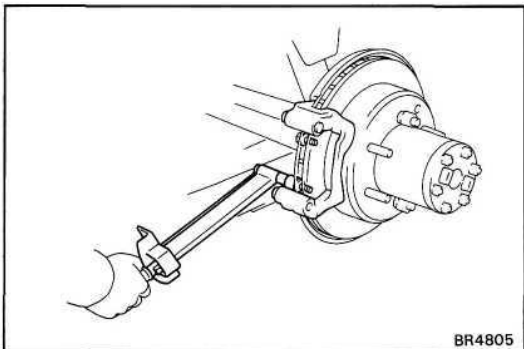

4. IF NECESSARY, REPLACE ROTOR DISC

- (a) Remove the torque plate from the knuckle.
- (b) Remove the wheel nuts of temporarily installed rotor disc and pull off the rotor disc from the axle hub.
- (c) Install a new rotor disc and temporarily fasten it with the wheel nuts.
- (d) Install the torque plate onto knuckle.

Torque: 1,050 kg-cm (76 ft-lb, 103 N-m)

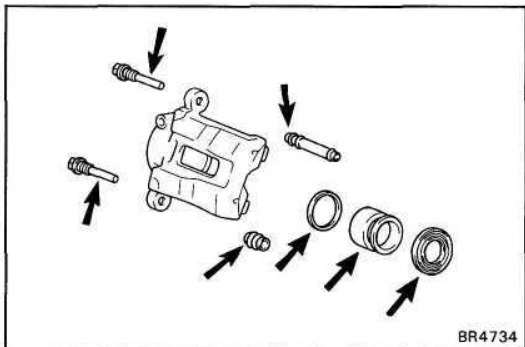

ASSEMBLY OF CYLINDER

(See page BR-50)

1. APPLY LITHIUM SOAP BASE GLYCOL GREASE TO FOLLOWING PARTS

- (a) Sliding bushing, hole plug and dust boot.
- (b) Piston, piston seal and cylinder boot.
- (c) Sliding pins.

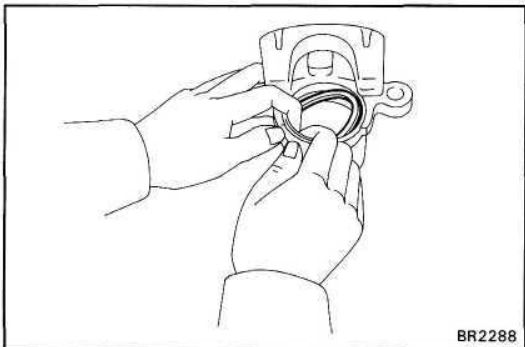

2. INSTALL PISTON SEAL AND PISTON IN CYLINDER

- (a) Install the piston seal into the cylinder.

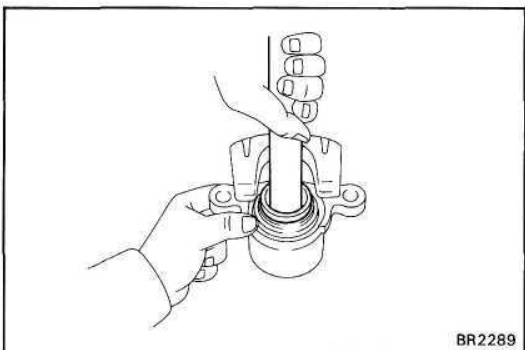

- (b) Install the piston into the cylinder.

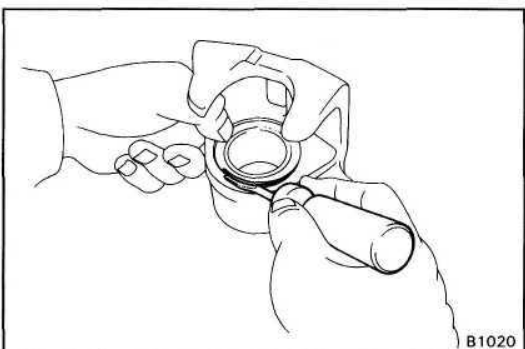

3. INSTALL CYLINDER BOOT AND SET RING IN CYLINDER

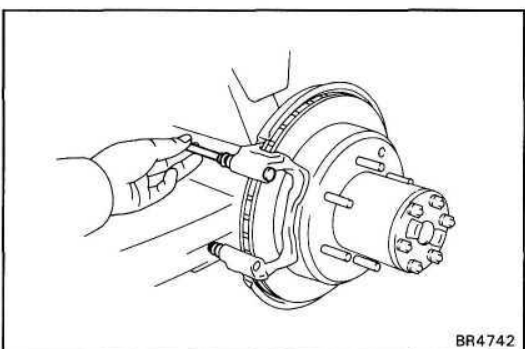

4. INSTALL PIN BOOTS AND SLIDING BUSHING

- (a) Install the pin boot into the sliding main pin side.
- (b) Using a plastic bar, install the cylinder sliding bushing into the sliding sub pin side.

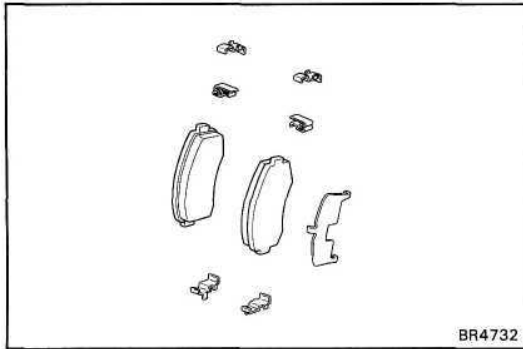

INSTALLATION OF CYLINDER

(See page BR-50)

1. **INSTALL PADS**
(See steps 7 to 8 on pages BR-51 and 52)

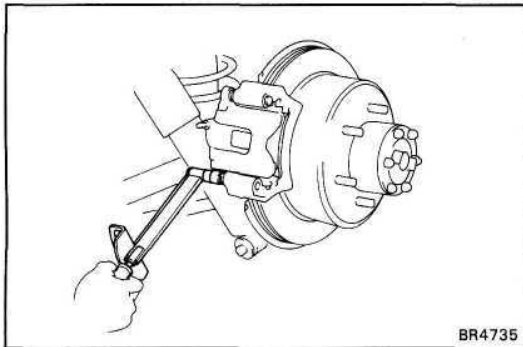

2. **INSTALL CYLINDER**
 - (a) Insert the brake cylinder.
 - (b) Install and torque the two installation bolts.**Torque: 900 kg-cm (65 ft-lb, 88 N-m)**

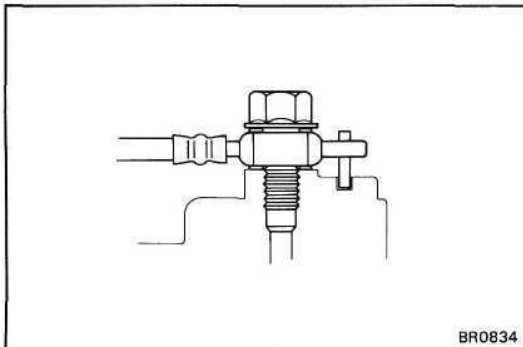

3. **CONNECT BRAKE HOSE TO CYLINDER**
Set the brake hose and new gaskets in position and install the union bolt.

Torque: 195 kg-cm (14 ft-lb, 19 N-m)

4. **FILL BRAKE RESERVOIR WITH BRAKE FLUID AND BLEED BRAKE SYSTEM**
(See page BR-7)
5. **CHECK FOR FLUID LEAKAGE**

Parking Brake (w/ Rear Disc Brake) COMPONENTS

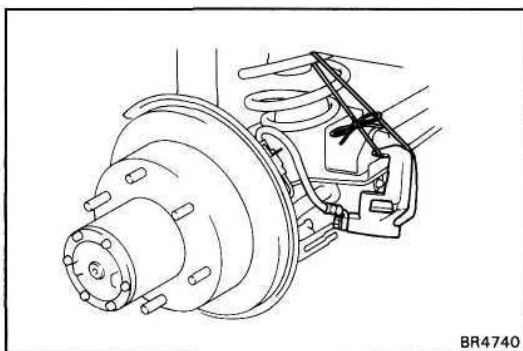
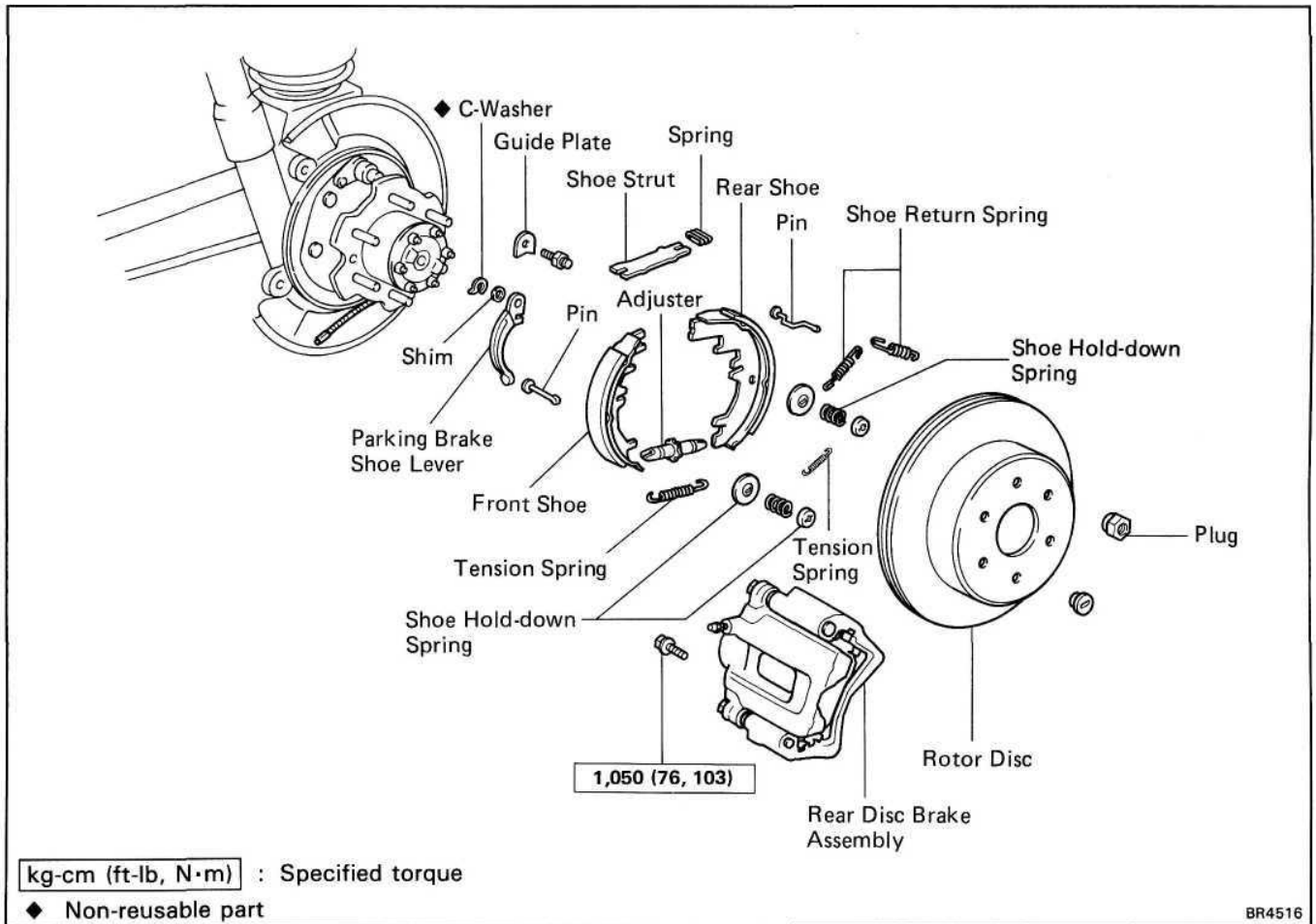

DISASSEMBLY OF PARKING BRAKE

1. REMOVE REAR DISC BRAKE ASSEMBLY

- (a) Remove the two mounting bolts and remove the disc brake assembly.
- (b) Suspend the disc brake so the hose is not stretched.

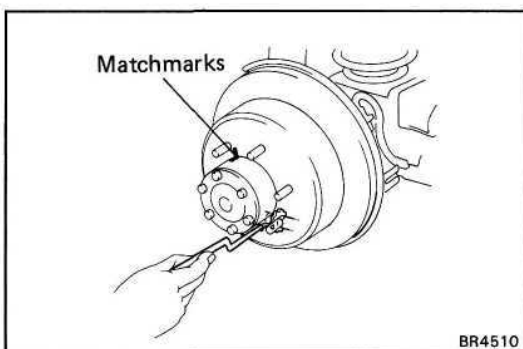

2. REMOVE ROTOR DISC

Place the matchmarks on the rotor disc and rear axle shaft, and remove the rotor disc.

HINT: If the drum cannot be removed easily, return the shoe adjuster until the wheel turns freely.

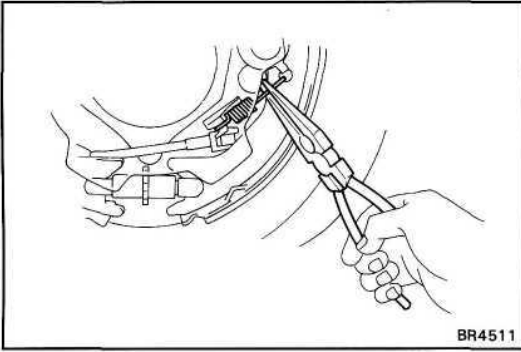

3. REMOVE TENSION SPRING

Using pliers, remove the tension spring.

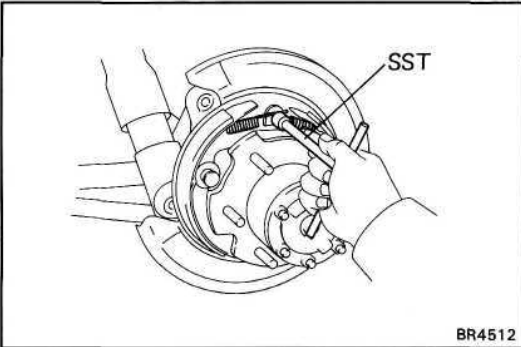

4. REMOVE SHOE RETURN SPRINGS

Using SST, remove the shoe return springs.
SST 09717-20010

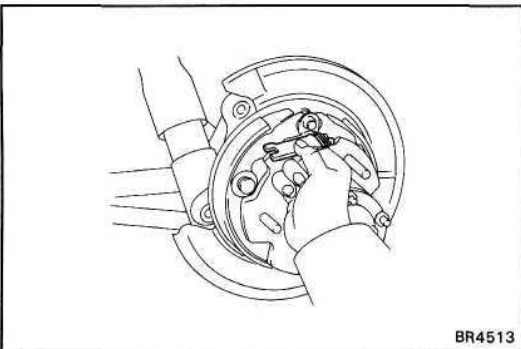

5. REMOVE SHOE STRUT WITH SPRING

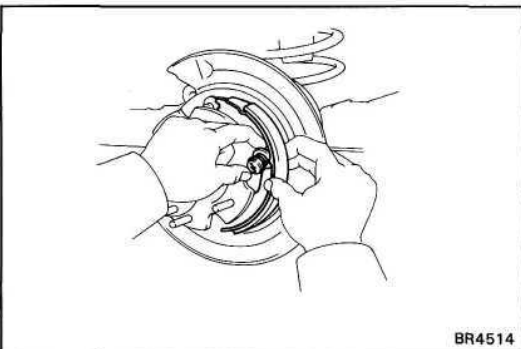

6. REMOVE REAR SHOE, ADJUSTER AND TENSION SPRING

- (a) Slide out the rear shoe, and remove the rear shoe and adjuster.
- (b) Remove the lower side tension spring.

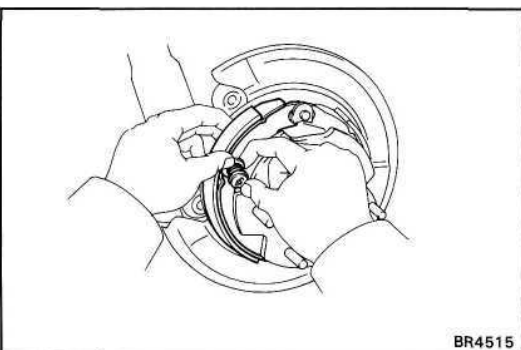

7. REMOVE FRONT SHOE

- (a) Slide out front shoe.
- (b) Disconnect the parking brake cable from the parking brake shoe lever.
- (c) Remove the shoe hold-down spring cups, springs and pins.

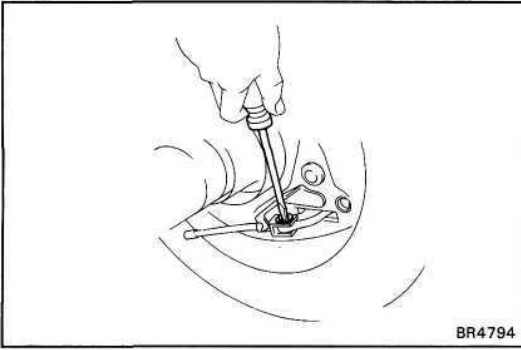

8. IF NECESSARY, REMOVE AND DISASSEMBLE PARKING BRAKE BELLCRANK ASSEMBLY

- (a) Using a screwdriver, remove the C-washer.
- (b) Remove the pin and disconnect the parking brake cable No. 2 from the bellcrank.

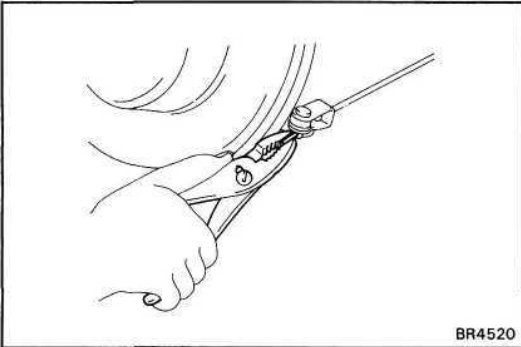

- (c) Remove the clip.
- (d) Remove the pin and wave washer, then disconnect the parking brake cable.

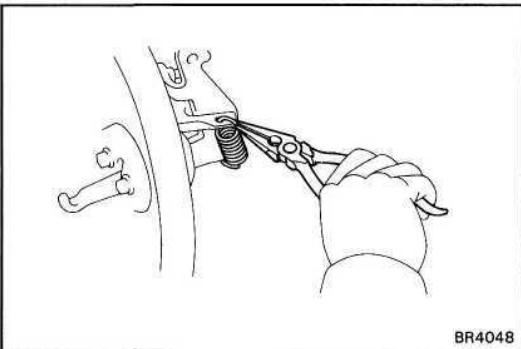

- (e) Remove the tension spring.

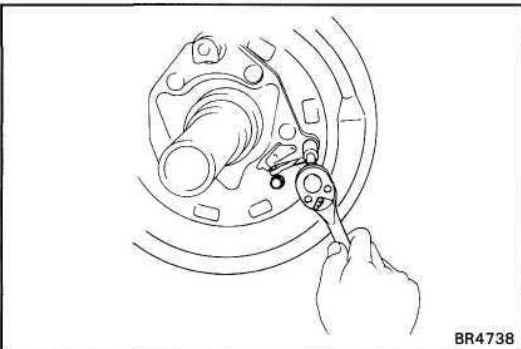

- (f) Remove the two bolts and parking brake bellcrank assembly.
- (g) Remove the boot from parking brake bellcrank bracket.

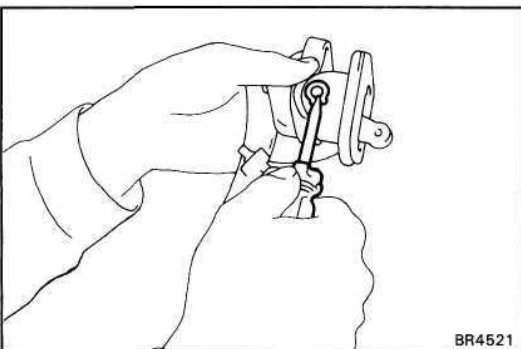

- (h) Using a screwdriver, remove the C-washer and pin.
- (i) Remove the parking brake bellcrank from the crank bracket.
- (j) Remove the boot.

INSPECTION AND REPAIR OF PARKING BRAKE COMPONENTS

1. INSPECT DISASSEMBLED PARTS

Inspect the disassembled parts for wear, rust or damage.

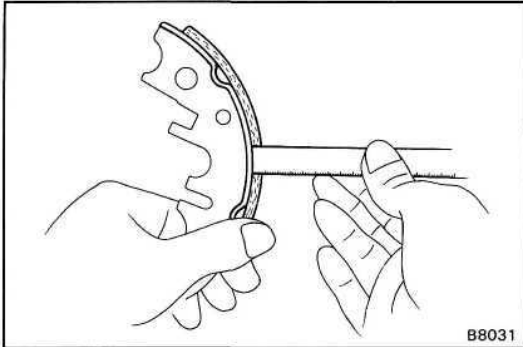

2. MEASURE BRAKE SHOE LINING THICKNESS

Minimum thickness: 1.0 mm (0.039 in.)

Standard thickness: 4.0 mm (0.157 in.)

If the shoe lining is less than minimum or shows signs of uneven wear, replace the parking brake shoes.

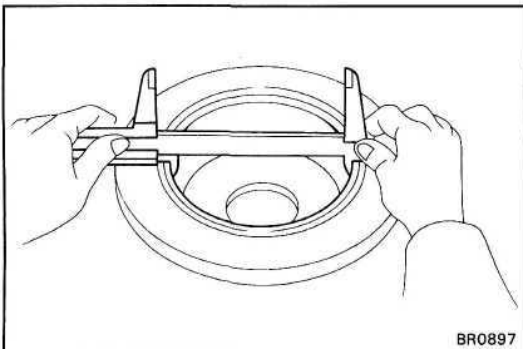

3. MEASURE BRAKE DISC INNER DIAMETER

Maximum inner diameter: 211 mm (8.31 in.)

Standard inner diameter: 210 mm (8.27 in.)

If the disc is scored or worn, the brake disc may be lathed to the maximum inner diameter.

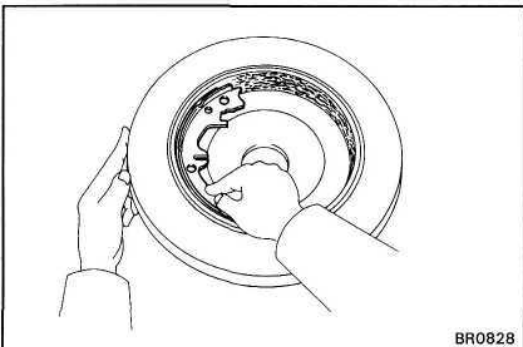

4. INSPECT PARKING BRAKE SHOE LINING AND DISC FOR PROPER CONTACT

If the contact between the brake lining and disc is improper, repair the lining with a brake shoe grinder, or replace the brake shoe assembly.

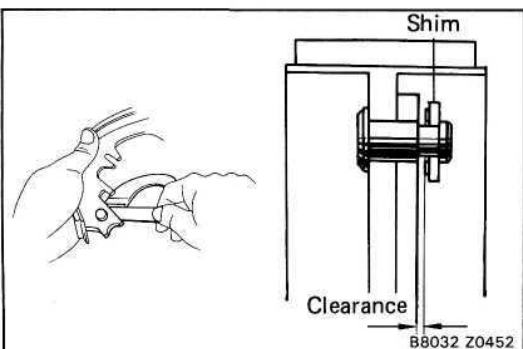

5. MEASURE CLEARANCE BETWEEN PARKING BRAKE SHOE AND LEVER

Using a feeler gauge, measure the clearance.

Standard clearance: Less than 0.35 mm (0.0138 in.)

If the clearance is not within specification, replace the shim with one of the correct size.

Thickness mm (in.)	
0.3 (0.012)	0.9 (0.035)
0.6 (0.024)	

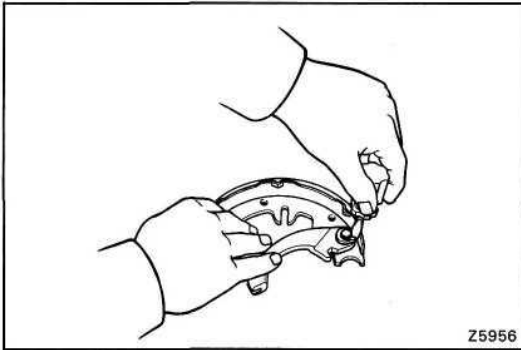
**6. IF NECESSARY, REPLACE SHIM**

- (a) Remove the parking brake shoe lever, and install the correct size shim.

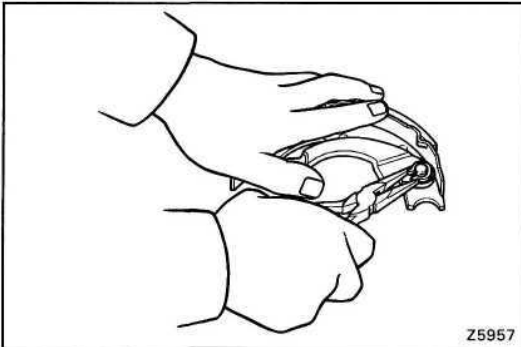

- (b) Install the parking brake shoe lever with a new C-washer.
- (c) Remeasure the clearance.

ASSEMBLY OF PARKING BRAKE

(See page BR-57)

HINT: Assemble the parts in the correct direction as shown.

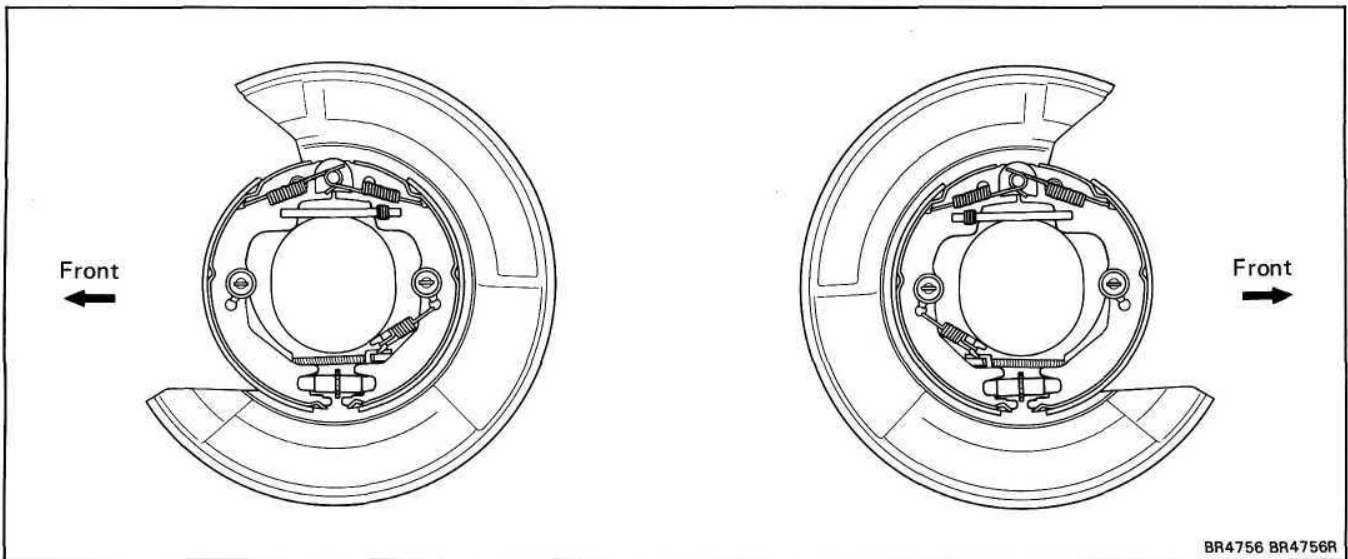

BR4756 BR4756R

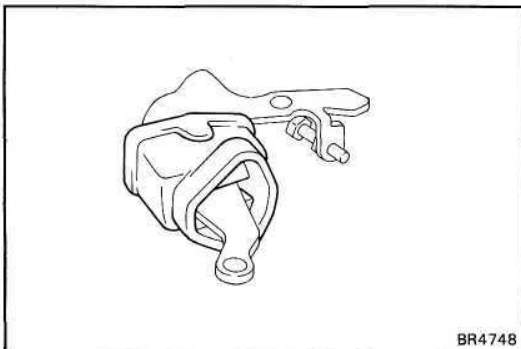

BR4748

1. **IF NECESSARY, ASSEMBLE AND INSTALL PARKING BRAKE BELLCRANK ASSEMBLY**

- (a) Apply lithium soap base glycol grease to the boot.
- (b) Install the boot to the parking brake bellcrank.

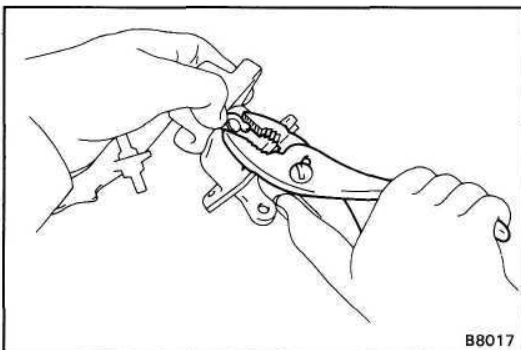

B8017

- (c) Install the parking brake bellcrank to the bellcrank bracket.
- (d) Install the pin with a new C-washer.

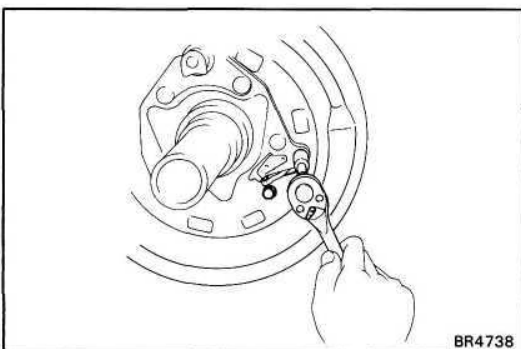

BR4738

- (e) Install the parking brake bellcrank assembly on the backing plate with two bolts.
- (f) Torque the bolts.

Torque: 130 kg-cm (9 ft-lb, 13 N-m)

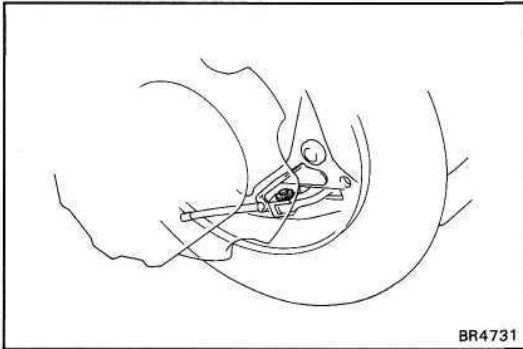

- (g) Using pliers, connect parking brake cable No. 2 to the bellcrank with the pin and a new C- washer.

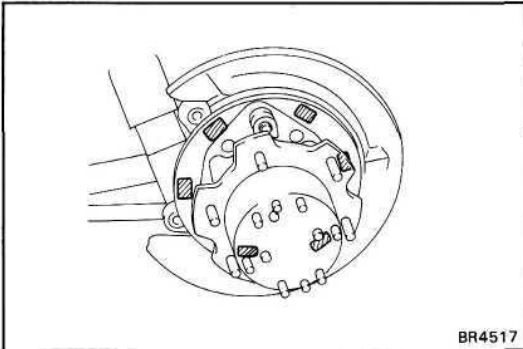

2. APPLY HIGH TEMPERATURE GREASE ON BACKING PLATE AS SHOWN

Apply high temperature grease to the sliding surfaces of the shoe.

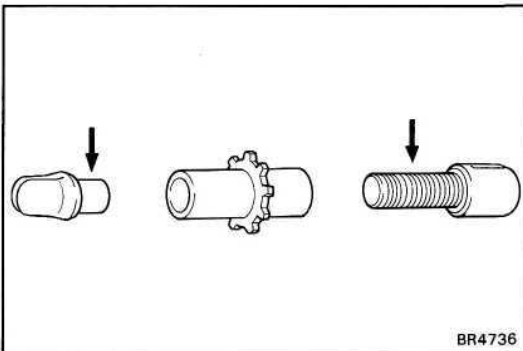

3. APPLY HIGH TEMPERATURE GREASE TO ADJUSTER AS SHOWN

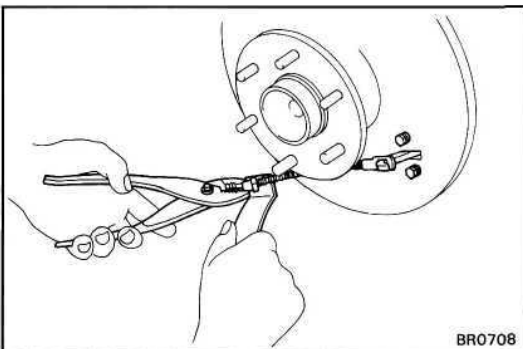

4. CONNECT PARKING BRAKE CABLE TO FRONT SHOE

Connect the parking brake cable to the front shoe.

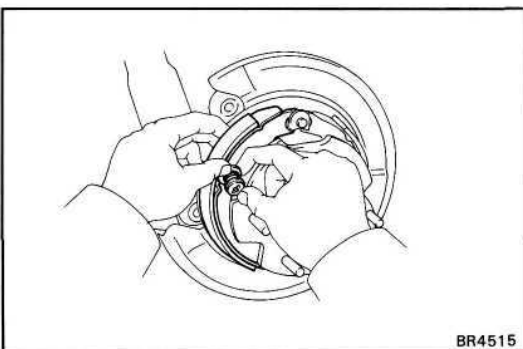

5. INSTALL FRONT SHOE

- (a) Install the pins, cups and shoe hold-down springs to the backing plate.
 (b) Slide in the front shoe between the shoe hold-down spring cup and the backing plate.

NOTICE: Do not allow oil or grease to get on the rubbing face.

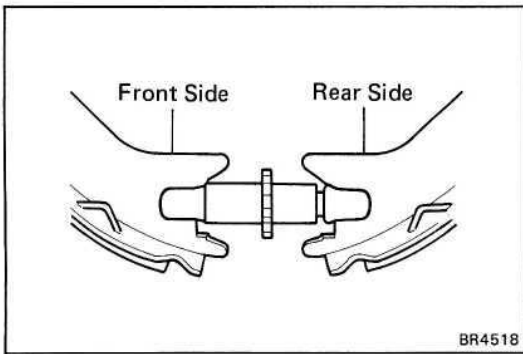

6. INSTALL TENSION SPRING, REAR SHOE AND ADJUSTER

- Install the lower side tension spring to the front shoe.
- Install the rear shoe to the tension spring.
- Install the adjuster between the front and rear shoes.

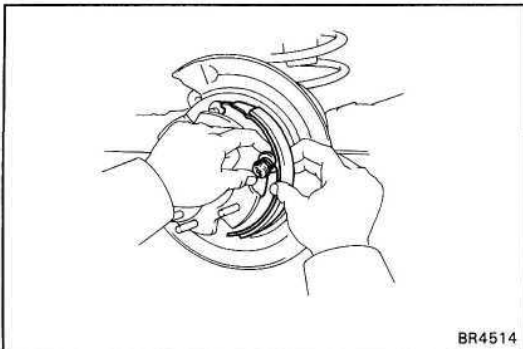

- Slide in the rear shoe between the shoe hold-down spring cup and the backing plate.

NOTICE: Do not allow oil or grease on the rubbing face.

- Using pliers, install the tension spring.

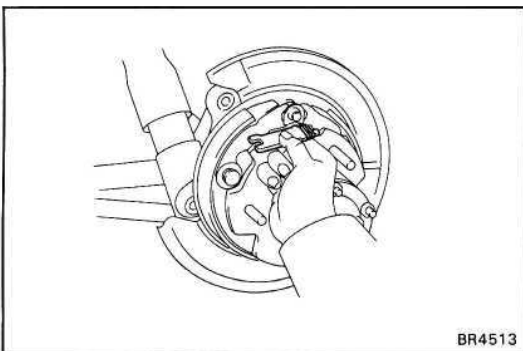

7. INSTALL STRUT WITH SPRING

Install the strut and spring with the spring facing rearward.

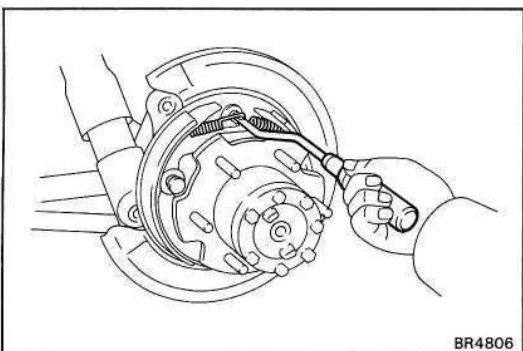

8. INSTALL SHOE RETURN SPRINGS

Using SST, install the front return spring and then install the rear return spring.

SST 09718-20010

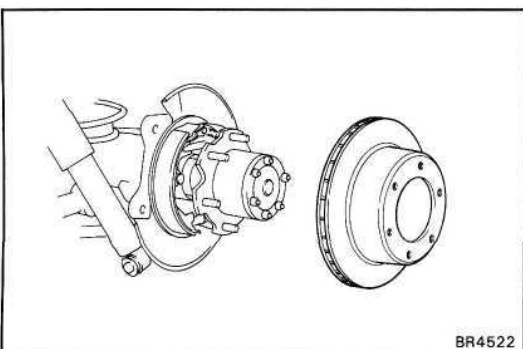

9. INSTALL ROTOR DISC

Align the matchmarks on the rear axle shaft and rotor disc, and install the rotor disc.

HINT: If there are no matchmarks, align the groove on the rear axle shaft flange with the service hole on the disc.

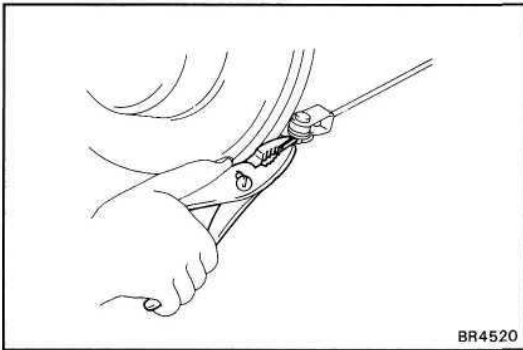
**10. CONNECT PARKING BRAKE CABLE**

- (a) Connect the parking brake cable to the bellcrank assembly with the pin, wave washer and clip.
- (b) Using pliers, install the cotter pin.

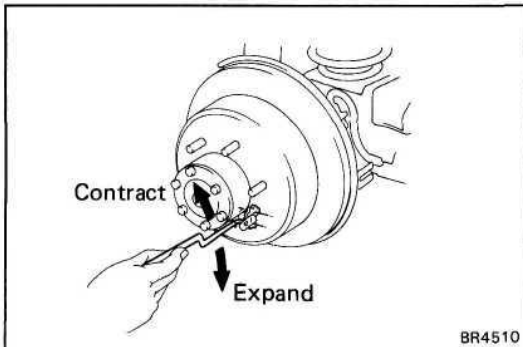
**11. ADJUST PARKING BRAKE SHOE CLEARANCE**

- (a) Temporarily install the hub nuts.
- (b) Remove the hole plug.
- (c) Turn the adjuster and expand the shoes until rotor disc locks.
- (d) Return the adjuster eight notches.
- (e) Install the hole plug.

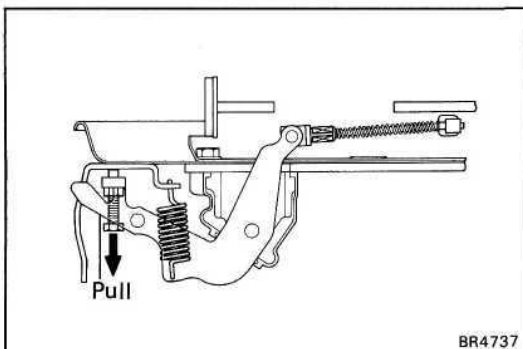
**12. IF NECESSARY ADJUST BELLCRANK**

- (a) Pull the bellcrank until all play in the interior linkage is taken up.
- (b) Screw in the bellcrank adjusting bolt to where it contacts on the dust seal.
- (c) Loosen if one turn, and lock it at that position with the lock nut.

Torque: 55 kg-cm (47.7 ft-lb, 5.4 N-m)

- (d) Install the bellcrank spring.

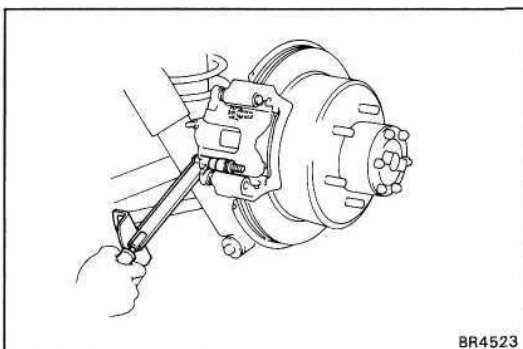
**13. INSTALL REAR DISC BRAKE ASSEMBLY**

Install the disc brake assembly and torque the two mounting bolts.

Torque: 1,050 kg-cm (76 ft-lb, 103 N-m)

14. INSTALL REAR WHEEL**15. BEDDING DOWN PARKING BRAKE SHOES AND DISC**

- (a) Drive the vehicle at about 50 km/h (31 mph) on a safe, level and dry road.
- (b) With the parking brake release button pushed in, pull on the lever with 9 kg (19.8 lb, 88 N) of force.
- (c) Drive the vehicle for about 400 meters (0.25 mile) in this condition.
- (d) Repeat this procedure two or three times.

16. RECHECK AND ADJUST PARKING BRAKE LEVER TRAVEL

LOAD SENSING PROPORTIONING AND BY-PASS VALVE COMPONENTS

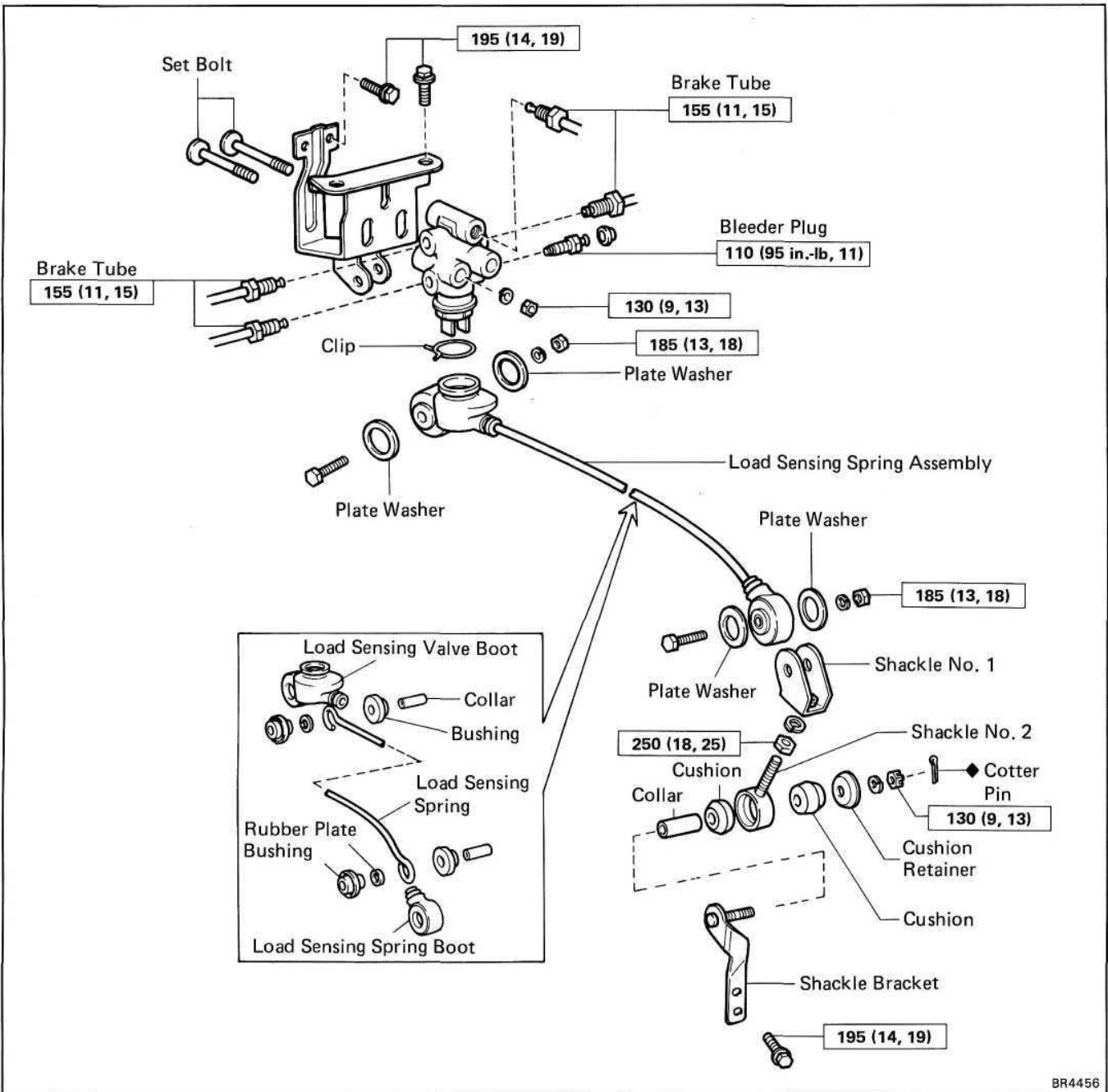

BR4456

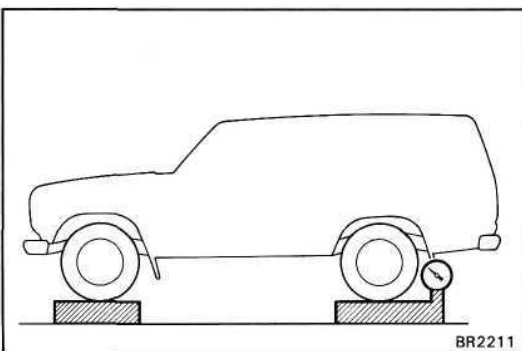

CHECK AND ADJUSTMENT OF FLUID PRESSURE

1. SET REAR AXLE LOAD

Rear axle load (include vehicle weight):

1,150 kg (2,535 lb)

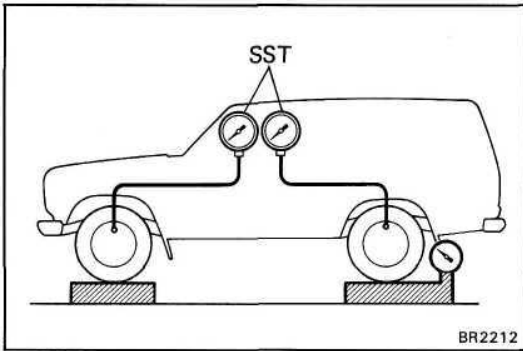

2. **INSTALL LSPV GAUGE (SST) AND BLEED AIR**
SST 09709-29017

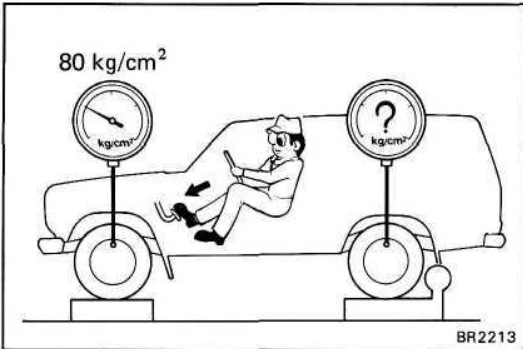

3. **RAISE FRONT BRAKE PRESSURE TO 80 kg/cm² (1,138 psi, 7,845 kPa) AND CHECK REAR BRAKE PRESSURE**

Rear brake pressure:

45 ± 6 kg/cm² (640 ± 85 psi, 4,413 ± 588 kPa)

HINT: The brake pedal should not be depressed twice and/or returned while setting to the specified pressure. Read the value of rear brake pressure two seconds after adjusting the specified fluid pressure.

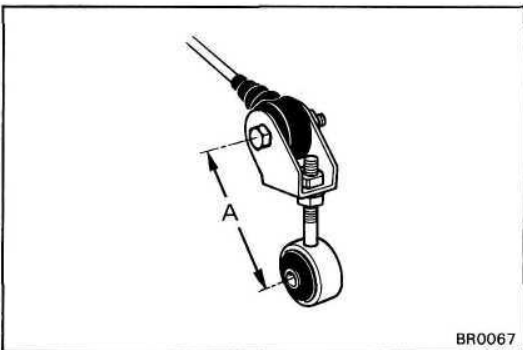

4. **IF NECESSARY, ADJUST FLUID PRESSURE**

- Disconnect the No. 2 shackle from the shackle bracket.
- Adjust the length of the No. 2 shackle turning it.
Low pressure — Lengthen A
High pressure — Shorten A

Initial set: 90 mm (3.54 in.)

Adjusting range: 84 — 96 mm (3.31 — 3.78 in.)

HINT: One turn of the No. 2 shackle changes the fluid pressure about following specification.

1.0 kg/cm² (14.2 psi, 98.1 kPa)

- In the event pressure cannot be adjusted by the No. 2 shackle, raise or lower the valve body.

Low pressure — Lower
High pressure — Raise

- Torque the nuts.

Torque: 130 kg-cm (9 ft-lb, 13 N-m)

- Adjust the length of the No. 2 shackle again.

If it cannot be adjusted, inspect the valve housing.

- Connect the No.2 shackle to the shackle bracket.

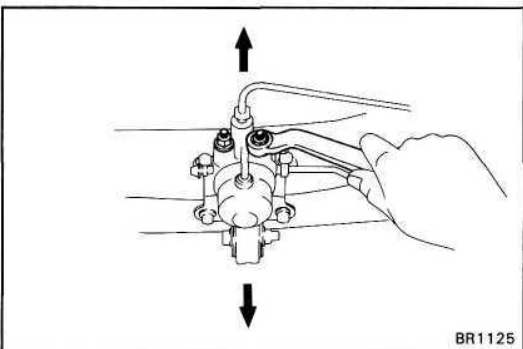

5. **IF NECESSARY, CHECK VALVE BODY**

- Assemble the valve body in the upper most position.

HINT: When the brakes are applied, the piston will move down about 1 mm (0.04 in.). Even at this time, the piston should not make contact with or move the load sensing spring.

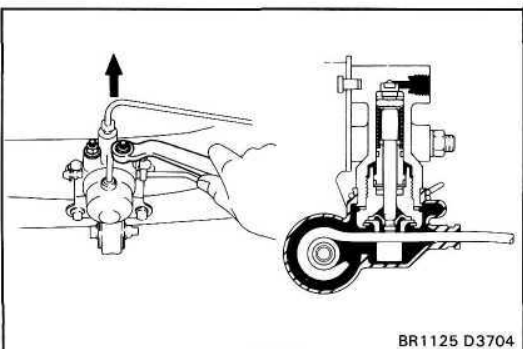

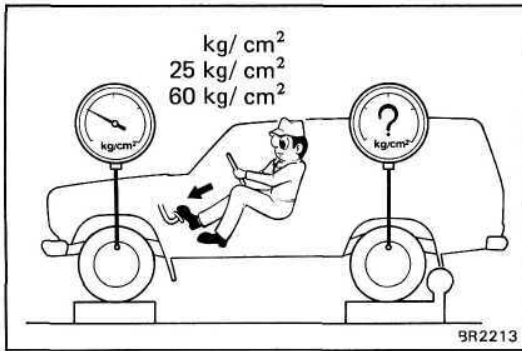

(b) In this position, check the rear brake pressure.

kg/cm² (psi, kPa)

Front brake pressure	Rear brake pressure
10 (142, 981)	10 (142, 981)
25 (356, 2,452)	11.8 – 15.8 (168 – 225, 1,157 – 1,549)
60 (853, 5,884)	19.0 – 26.0 (270 – 370, 1,863 – 2,550)

If the measured value is not within standard, replace the valve body.

REMOVAL OF LSP & BV

(See page BR-66)

1. DISCONNECT SHACKLE NO. 2 FROM BRACKET

- Remove the cotter pin.
- Remove the nut and disconnect the shackle No. 2 from the bracket.
- Remove the two retainers, two bushings and collar.

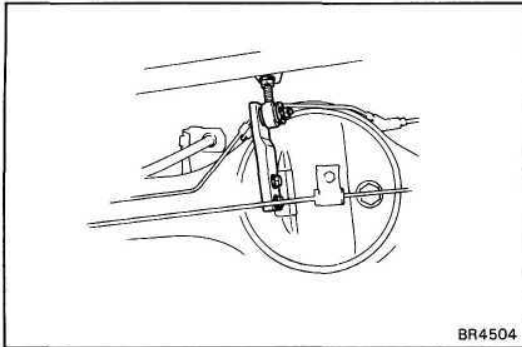

2. REMOVE LSP & BV ASSEMBLY

- Using SST, disconnect the brake tubes from the valve body.

SST 09751-36011

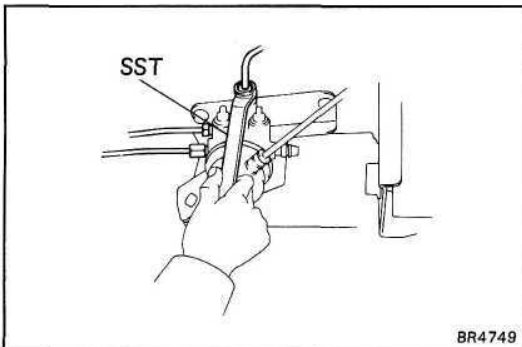

- Remove the valve bracket mounting bolts and nut, then remove the LSP & BV assembly.

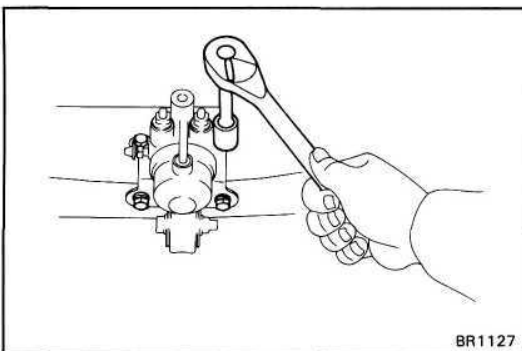

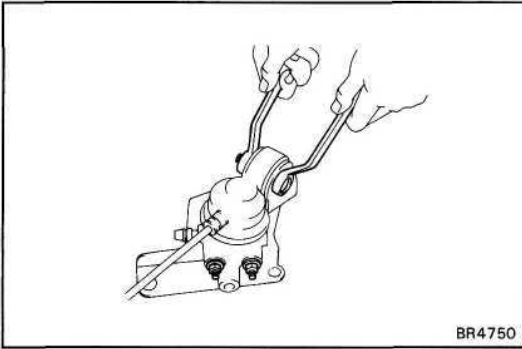

DISASSEMBLY OF LSP & BV ASSEMBLY

1. REMOVE VALVE BRACKET

- (a) Remove the nut and bolt as shown.
- (b) Remove the two nuts, and remove the bracket and set plate from the valve body.

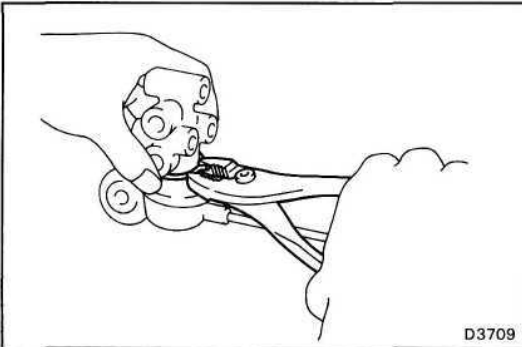

2. DISCONNECT SPRING FROM VALVE

Using pliers, remove the clip, and remove the spring from the valve.

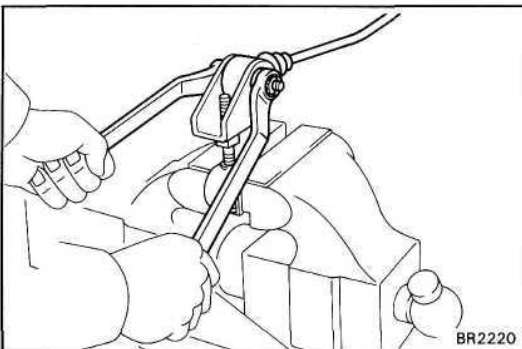

3. REMOVE SHACKLE NO. 1 AND NO. 2

- (a) Remove the bolt and nut, then remove the following parts.
 - Load sensing spring
 - Two plate washers
- (b) Loosen the lock nut, and remove the shackle No. 1 from the shackle No. 2.

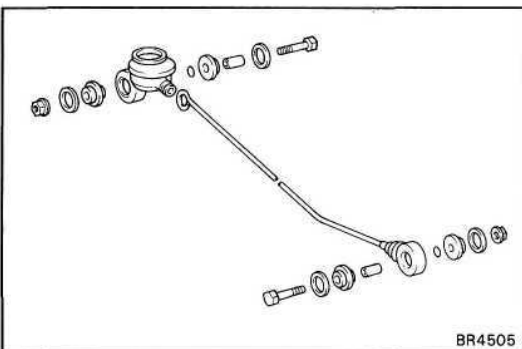

4. DISASSEMBLE LOAD SENSING SPRING

Disassemble the following parts.

- (a) Bushings
- (b) Collars
- (c) Rubber plates
- (d) Load sensing valve boot
- (e) Load sensing spring boot

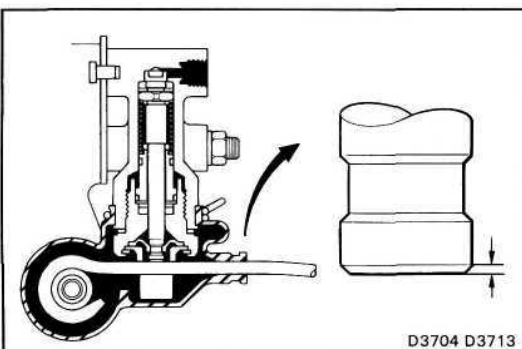

INSPECTION OF LSP & BV

INSPECT VALVE PISTON PIN AND LOAD SENSING SPRING CONTACT SURFACE FOR WEAR

Wear limit: 0.7 mm (0.028 in.)

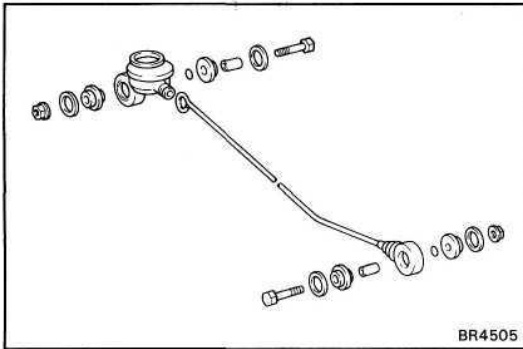

ASSEMBLY OF LSP & BV ASSEMBLY

(See page BR-66)

1. ASSEMBLE FOLLOWING PARTS TO LOAD SENSING SPRING

- (a) Load sensing valve boot
- (b) Load sensing spring boot
- (c) Collars
- (d) Rubber plates
- (e) Bushings

HINT:

- Apply lithium soap base glycol grease to all rubbing areas.
- Do not mistake the valve side for the shackle side of the load sensing spring.

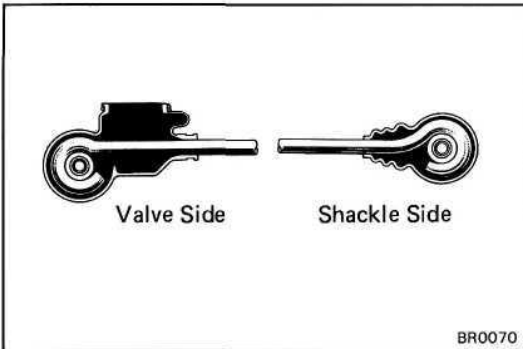

2. INSTALL SHACKLE NO. 1 AND NO. 2 TO LOAD SENSING SPRING

- (a) Install the lock nut and shackle No. 1 to the shackle No. 2.
- (b) Install the shackle to the load sensing spring through the two plate washers.

Torque: 185 kg-cm (13 ft-lb, 18 N-m)

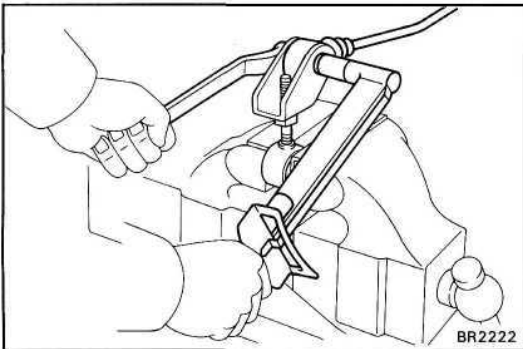

3. INSTALL LOAD SENSING SPRING TO VALVE BODY

Install the load sensing spring assembly to the load sensing valve with a clip.

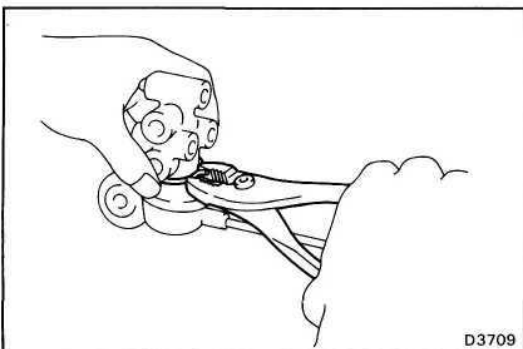

4. INSTALL VALVE BRACKET

- (a) Install the set plate to the valve assembly through the valve bracket and temporarily tighten the two valve body mounting nuts.

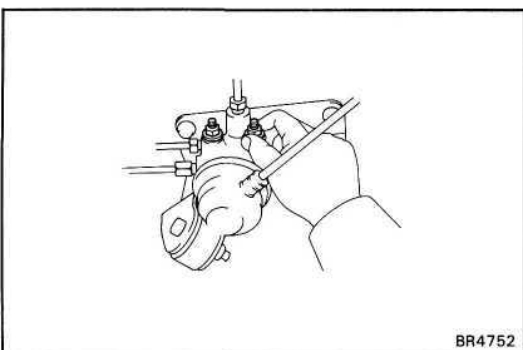

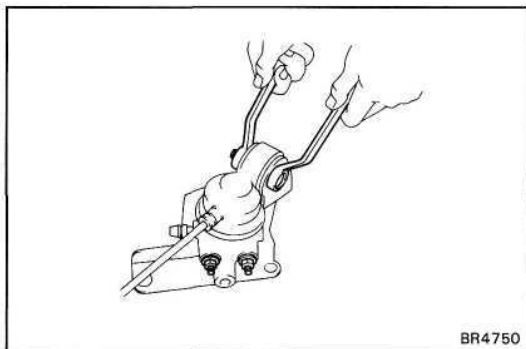

- (b) Torque the bolt and nut of load sensing spring boot through the two plate washers.

Torque: 185 kg-cm (13 ft-lb, 18 N-m)

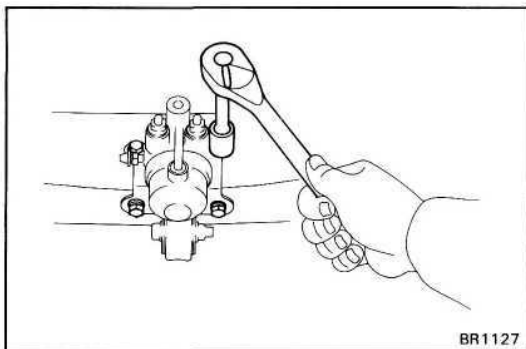

INSTALLATION OF LSP & BV

1. INSTALL LSP & BV ASSEMBLY

Install the LSP & BV assembly to the frame with four bolts.

Torque: 195 kg-cm (14 ft-lb, 19 N-m)

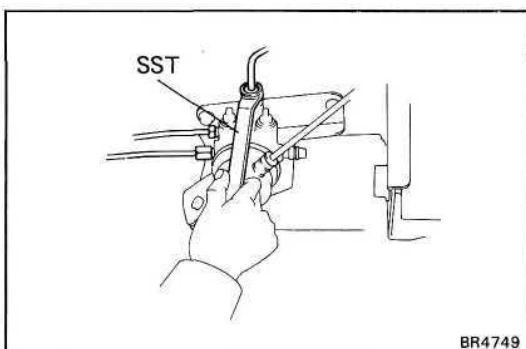

2. CONNECT BRAKE TUBES

Using SST, connect the brake tubes.

SST 09751-36011

Torque: 155 kg-cm (11 ft-lb, 15 N-m)

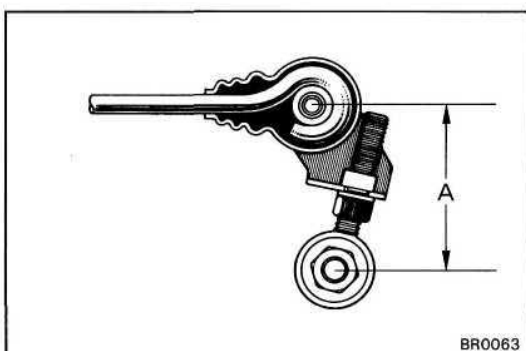

3. CONNECT SHACKLE NO. 2 TO BRACKET

- (a) Set the dimension A by turning the shackle No. 2.

Initial set: 90 mm (3.54 in.)

- (b) Tighten the lock nut.

Torque: 250 kg-cm (18 ft-lb, 25 N-m)

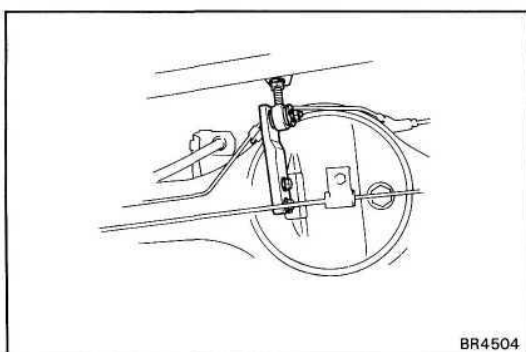

- (c) Install the two bushings and a collar to the load sensing spring shackle.

- (d) Install the load sensing spring to the shackle bracket with the two retainers and a nut.

Torque: 130 kg-cm (9 ft-lb, 13 N-m)

- (e) Install a new cotter pin.

4. SET REAR AXLE LOAD (See page BR-66)

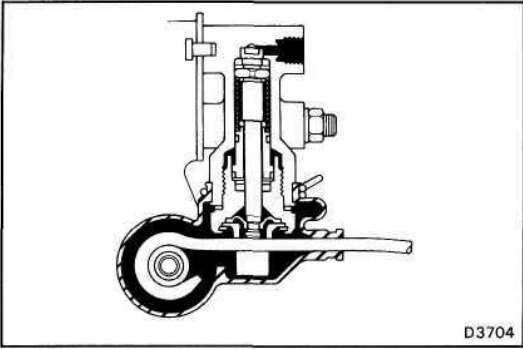
**5. SET VALVE BODY**

- (a) When pulling down the load sensing spring, confirm that the valve piston moves down smoothly.
- (b) Position the valve body so that the valve piston lightly contacts the load sensing spring.

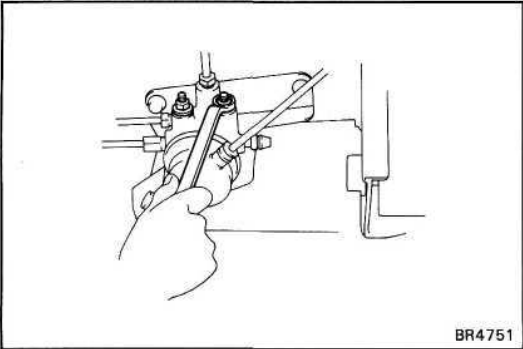

- (c) Tighten the valve body mounting nuts.

Torque: 130 kg-cm (9 ft-lb, 13 N-m)

6. BLEED BRAKE SYSTEM

(See page BR-7)

7. CHECK FOR FLUID LEAKAGE**8. CHECK AND ADJUST LSP & BV FLUID PRESSURE**

(See page BR-67)