BODY ELECTRICAL SYSTEM

	Page
GENERAL INFORMATION.....	BE-2
POWER SOURCE.....	BE-7
IGNITION SWITCH.....	BE-12
LIGHTING SYSTEM.....	BE-14
HEADLIGHT CLEANER SYSTEM.....	BE-34
WIPER AND WASHER SYSTEM.....	BE-36
COMBINATION METER.....	BE-47
DEFOGGER SYSTEM.....	BE-71
POWER WINDOW CONTROL SYSTEM.....	BE-75
POWER DOOR LOCK CONTROL SYSTEM.....	BE-83
SLIDING ROOF SYSTEM.....	BE-90
POWER MIRROR CONTROL SYSTEM.....	BE-95
POWER SEAT CONTROL SYSTEM.....	BE-97
SEAT HEATER SYSTEM.....	BE-99
CRUISE CONTROL SYSTEM.....	BE-103
FUEL TRANSFER SYSTEM.....	BE-126
AUDIO SYSTEM.....	BE-129
CLOCK.....	BE-162

GENERAL INFORMATION

Wiring Color Code

Wire colors are indicated by an alphabetical code.

- | | | |
|------------|------------------|------------|
| B = Black | L = Blue | R = Red |
| BR = Brown | LG = Light Green | V = Violet |
| G = Green | O = Orange | W = White |
| GR = Gray | P = Pink | Y = Yellow |

The first letter indicates the basic wire color and the second letter indicated the color of the stripe.

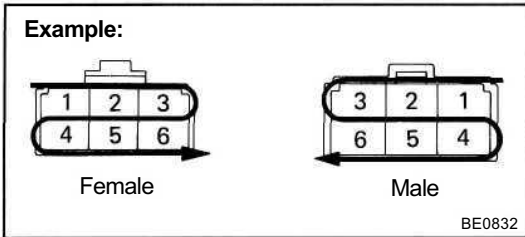
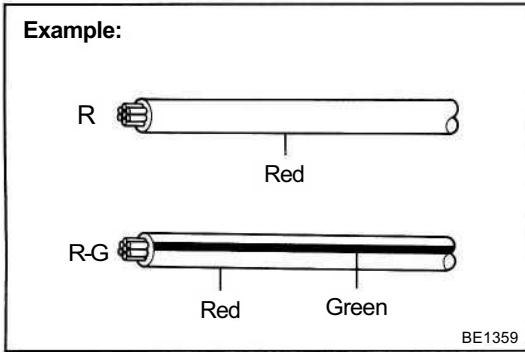

Connector

1. PIN NUMBER OF FEMALE CONNECTOR

Numbered in order from upper left to lower right.

2. PIN NUMBER OF MALE CONNECTOR

Numbered in order from upper right to lower left.

HINT: When connectors with different or the same number of terminals are used with the same parts, each connector name (letter of the alphabet) and pin number is specified.

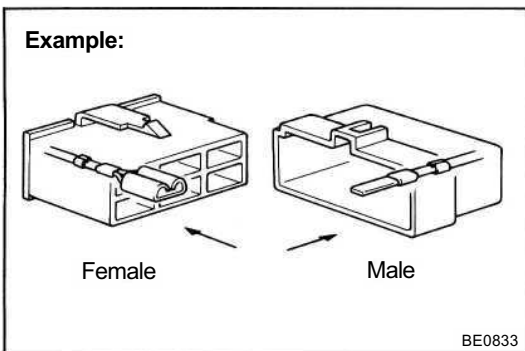
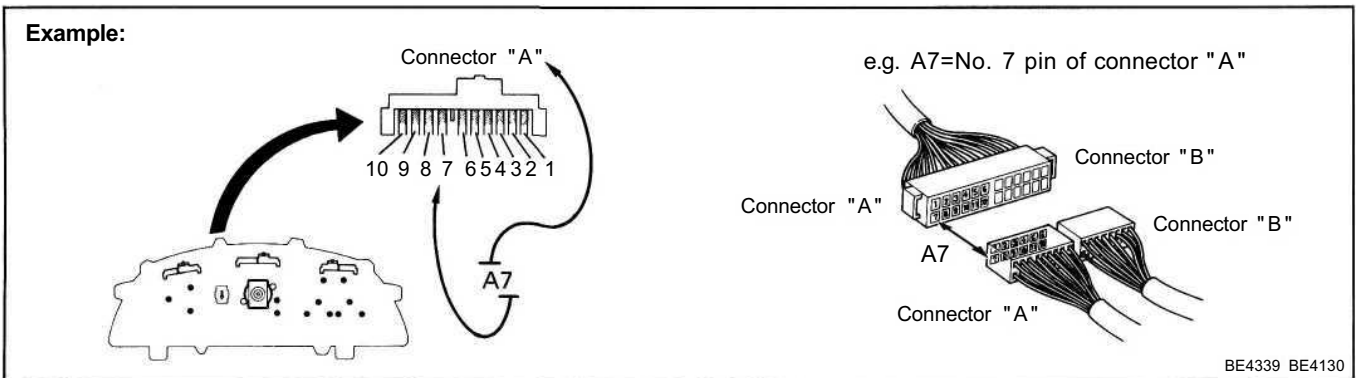

3. DISTINCTION OF MALE AND FEMALE CONNECTORS

Male and female connectors are distinguished by shape of their internal pins.

- All connectors are shown from the open end, and the lock is on top.
- To pull apart the connectors, pull on the connector itself, not the wires.

HINT: Check to see what kind of connector you are disconnecting before pulling apart.

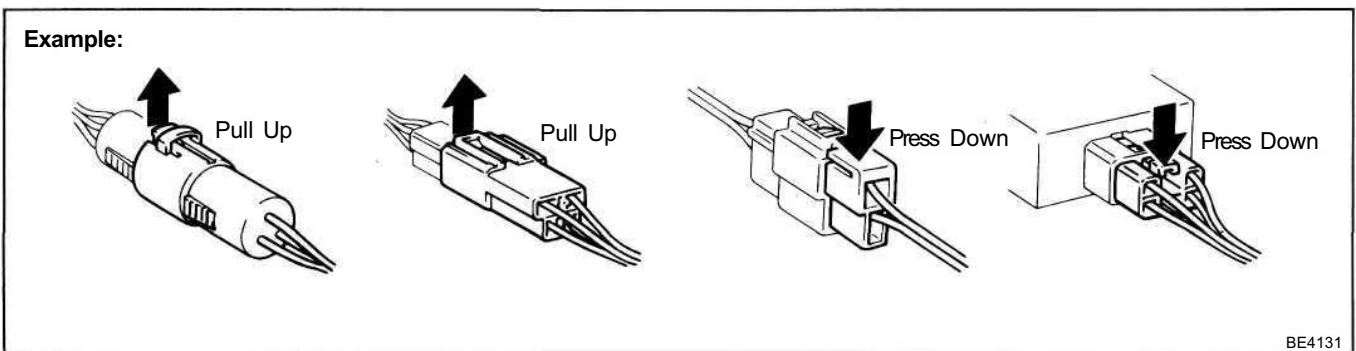

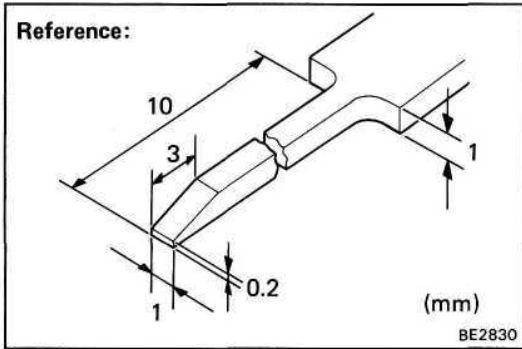

How to Replace Terminal

(with Terminal Retainer Type)

HINT: To remove the terminal for this type of connector, please construct and use the special tool or like object shown on the left.

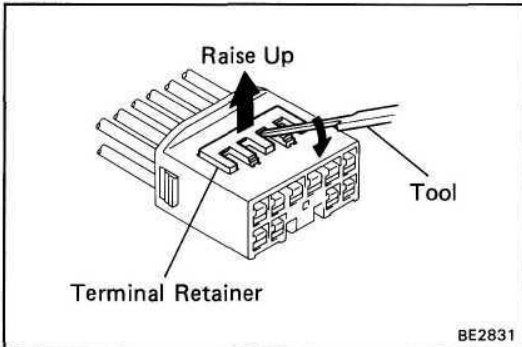

1. DISCONNECT CONNECTOR

Disconnect the connector according to the instructions on BE-2.

2. DISCONNECT TERMINAL FROM CONNECTOR

(a) Using the special tool, raise the retainer up to the temporary lock position.

HINT: The needle insertion position varies according to the connector's shape (number of terminals, etc.), so check the position before inserting it.

(b) Using the special tool, release the locking lug and pull the terminal out from rear.

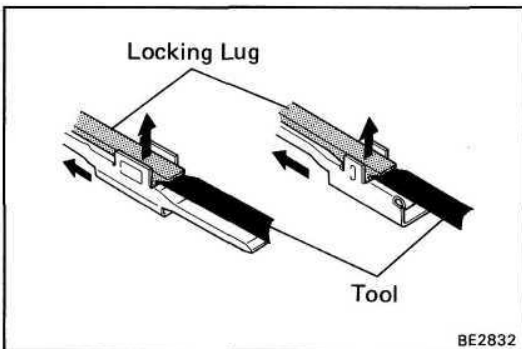

3. INSTALL TERMINAL TO CONNECTOR

(a) Insert the terminal.

HINT:

1. Make sure the terminal is positioned correctly.
2. Insert the terminal until the locking lug locks firmly.
3. Insert the terminal with retainer in the temporary lock position.

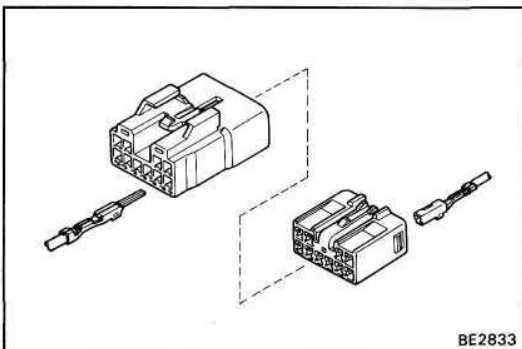

(b) Push the retainer in as far as the full lock position.

4. CONNECT CONNECTOR

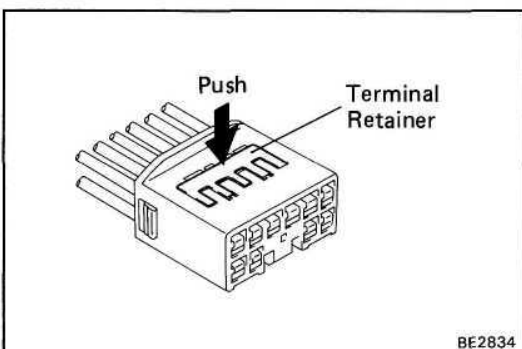

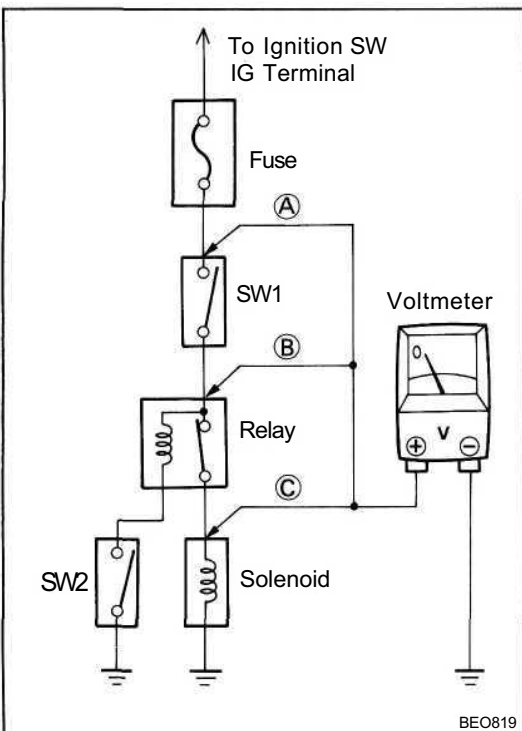
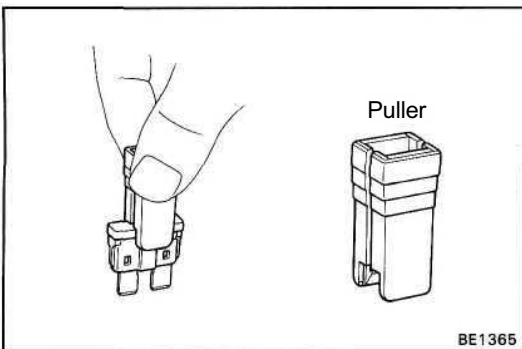
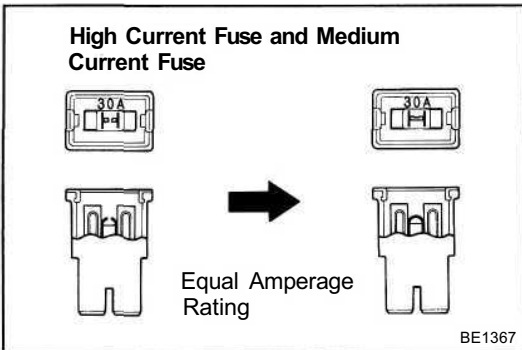
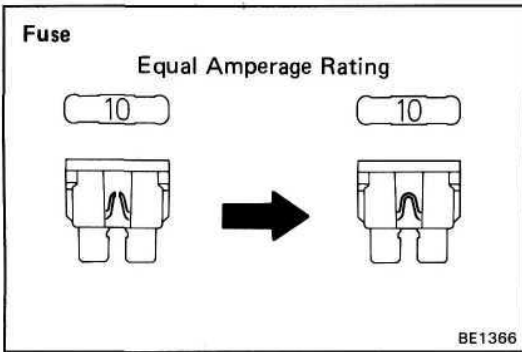

Replacement of High Current Fuse, Medium Current Fuse and Fuse

HINT: If replacing the fuse, be sure to replace it with a fuse with an equal amperage rating.

NOTICE:

1. Turn off all electrical components and the ignition switch before replacing a fuse. Do not exceed the fuse or fusible link amperage rating.
2. Always use a fuse puller for removing and inserting a fuse. Remove and insert straight in and out without twisting. Twisting could force open the terminals too much, resulting in a bad connection.

If a fuse continues to blow, a short circuit is indicated. The system must be checked by a qualified technician.

Check for Voltage

- (a) Establish conditions in which voltage is present at the check point.

Example:

(A) — Ignition switch on.

(B) — Ignition switch and switch 1 (SW1) on.

(C) — Ignition switch, switch 1 (SW1) and relay on (switch 2 (SW2) off).

- (b) Using a voltmeter, connect the negative (—) lead to a good ground point or negative (—) battery terminal and the positive (+) lead to the connector or component terminal. This check can be done with a test bulb instead of a voltmeter.

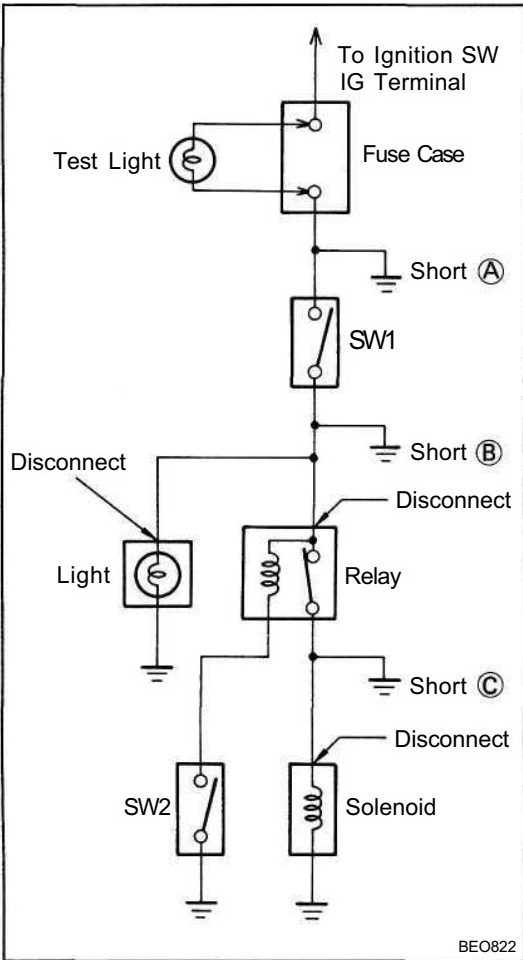

Check for Short Circuit

- (a) Remove the blown fuse and eliminate all loads from the fuse.
- (b) Connect a test bulb in place of the fuse.
- (c) Establish conditions in which the test bulb comes on.

Example:

- Ⓐ — Ignition switch on.
- Ⓑ — Ignition switch and switch 1 (SW1) on.
- Ⓒ — Ignition switch, switch 1 (SW1) and relay on (connect the relay) and switch 2 (SW2) off (or disconnect switch 2 (SW2)).

- (d) Disconnect and reconnect the connectors while watching the test bulb.
The short lies between the connector where the test bulb stays lit and the connector where the bulb goes out.
- (e) Find the exact location of the short by lightly shaking the problem wire along the body.

POWER SOURCE

Parts Location

Gasoline Engine

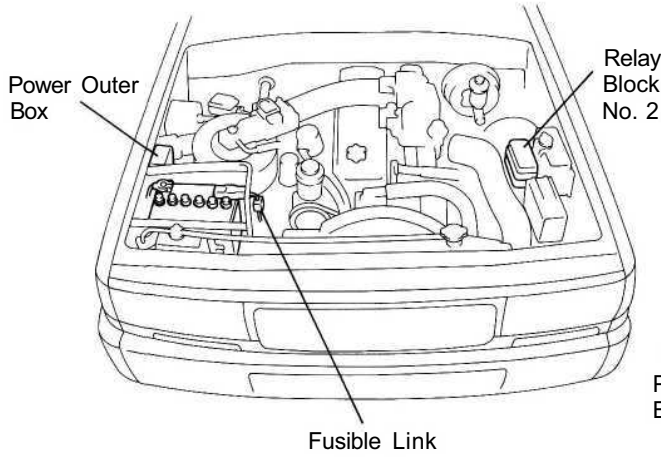

**Diesel Engine
(w/o 12/24 Volt Switchover System)**

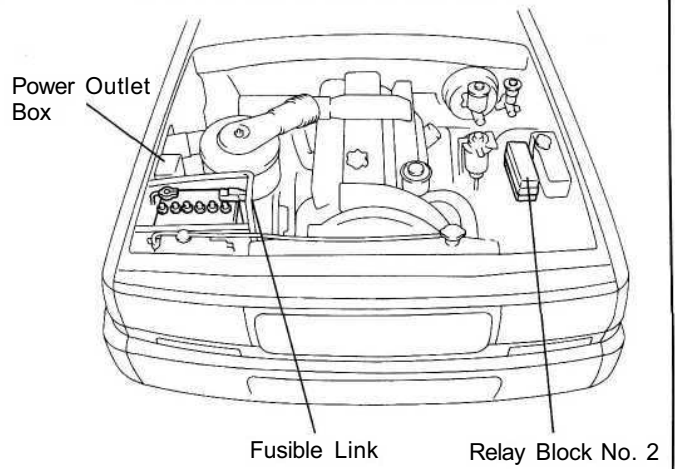

**Diesel Engine
(w/ 12/24 Volt Switchover System)**

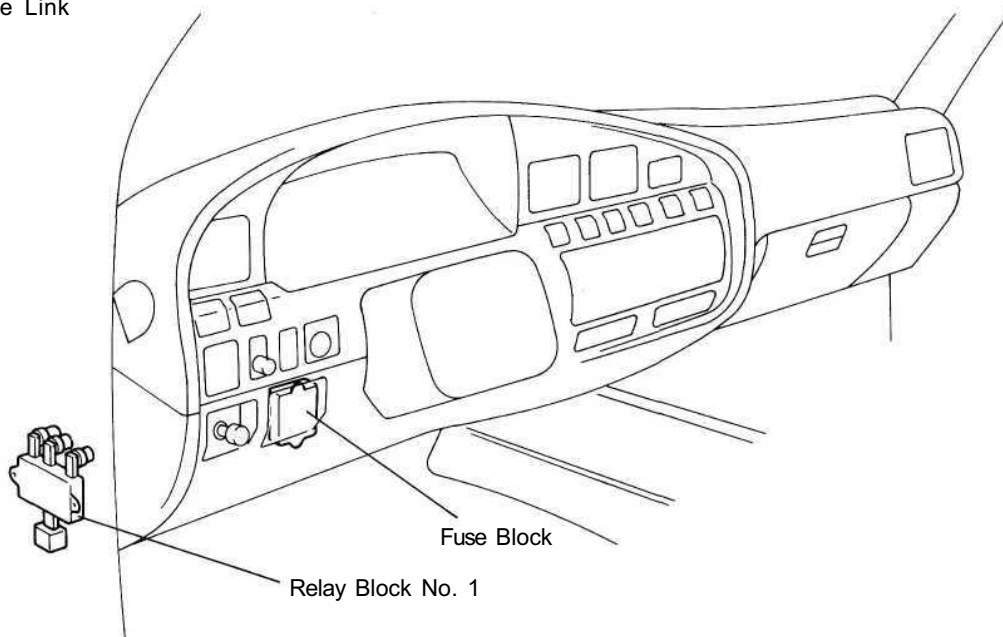
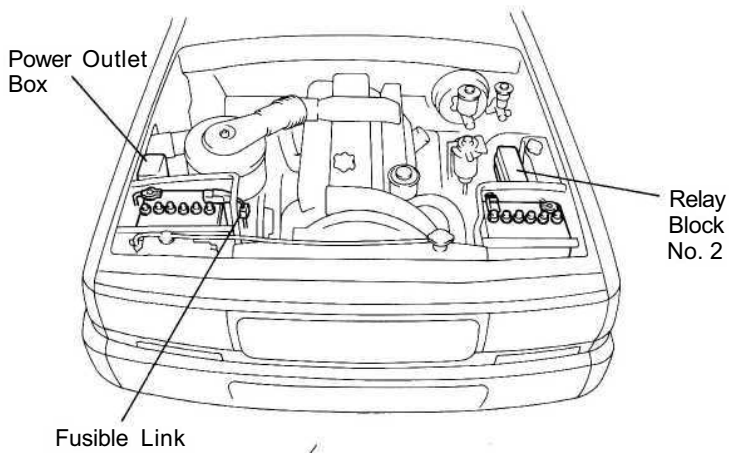

Parts Location (Cont'd)

Relay Block No. 2

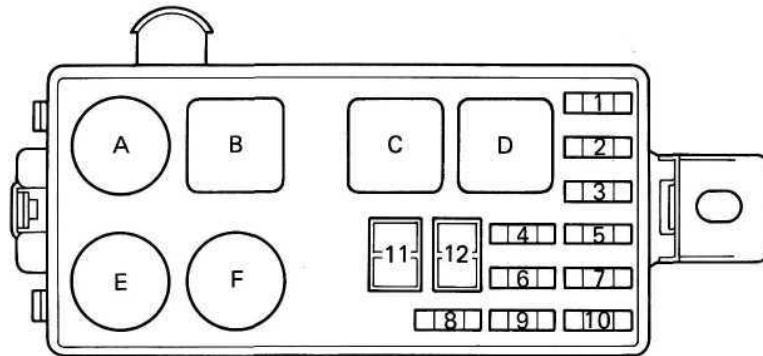

Fuses and High Current Fuses

1. HEAD (RH)	15A	7. HAZ-HORN	15A
HEAD (RH-HI)	15A*1	8. -	
2. HEAD (LH)	15A	9. CDS-FAN	20A
HEAD (LH-HI)	15A*1	10. DOME	10A
3. HEAD (RH-LO)	15A*1	11. AM1	50A
4. CHARGE	7.5A	12. -	
5. HEAD (LH-LO)	15A*1		
6. EFI	15A*2		
FUEL-HTR	20A*3		

Relays

- A. EFI Main Relay *2
Fuel Heater Relay *2
- B. Charge Light Relay *2
- C. Headlight Control Relay
- D. Dimmer Relay *1
- E. HORN Relay
- F. Condenser Fan Relay

- *1: Europe
- *2: 3F-E Engine
- *3: Diesel Engine

*4: Gasoline Engine w/ IC Alternator

Fuse Block

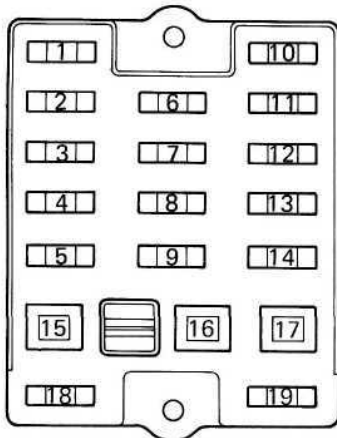

Fuses and Medium Current Fuse

1. CIG	15A	10. ECU-B	10A
2. TAIL	15A	11. REAR-HTR	20A
TAIL(RH)	10A*1	12. IGN	7.5A
3. TAIL(LH)	10A*1	13. A/C	10A
4. STOP	10A	14. DIFF	30A
5. DEFOG	20A	16. HEATER	30A
6. WIPER	20A	17. POWER	30A
7. GAUGE	10A	18. Spare	
8. TURN	7.5A	19. Spare	
9. ECU-IG	15A		

- *1: Europe

Parts Location (Cont'd)

Relay Block No. 1

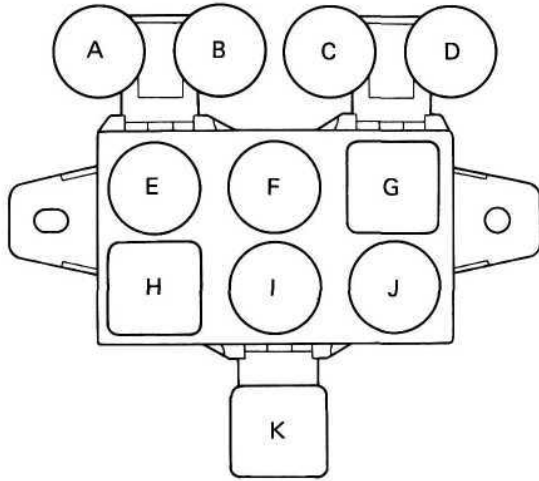

Relays

- A. Cooling Fan Relay
- B. Bulb Check Relay (Australia)
- C. Rear Fog Light Relay (Europe)
Blower Hi Relay (G.C.C. w/ A/C)
- D. -
- E. Deffogger Relay
- F. Power Main Relay
- G. Turn Signal Flasher
- H. Heater Relay
- I. Taillight Control Relay
- J. -
- K. Circuit Opening Relay

Power Outlet Box

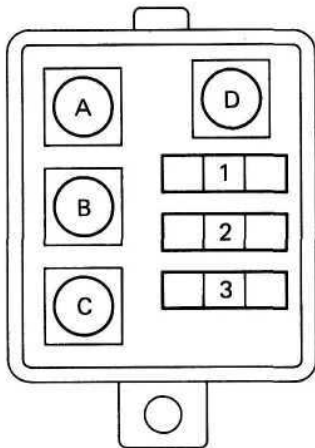

Fuse

- 1. ACC 10A
- 2. IG 10A
- 3. +B 20A

Terminal

No.	Terminal Name	Connected Parts
A	ACC	Ignition Switch ACC
B	IG	Ignition Switch IG1
C	+B	FL MAIN
D	-E	Ground

Wiring Diagram

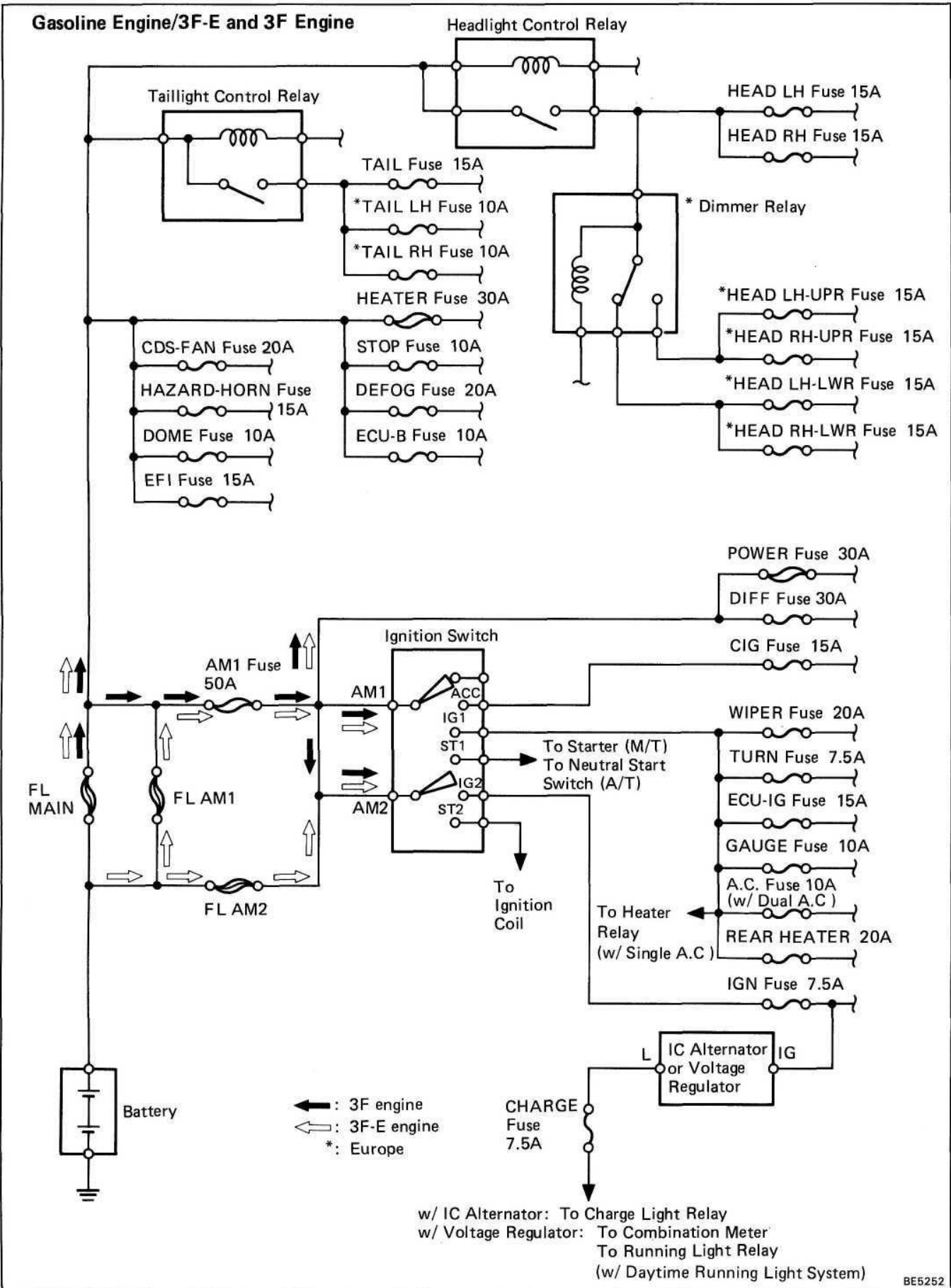

Wiring Diagram (Cont'd)

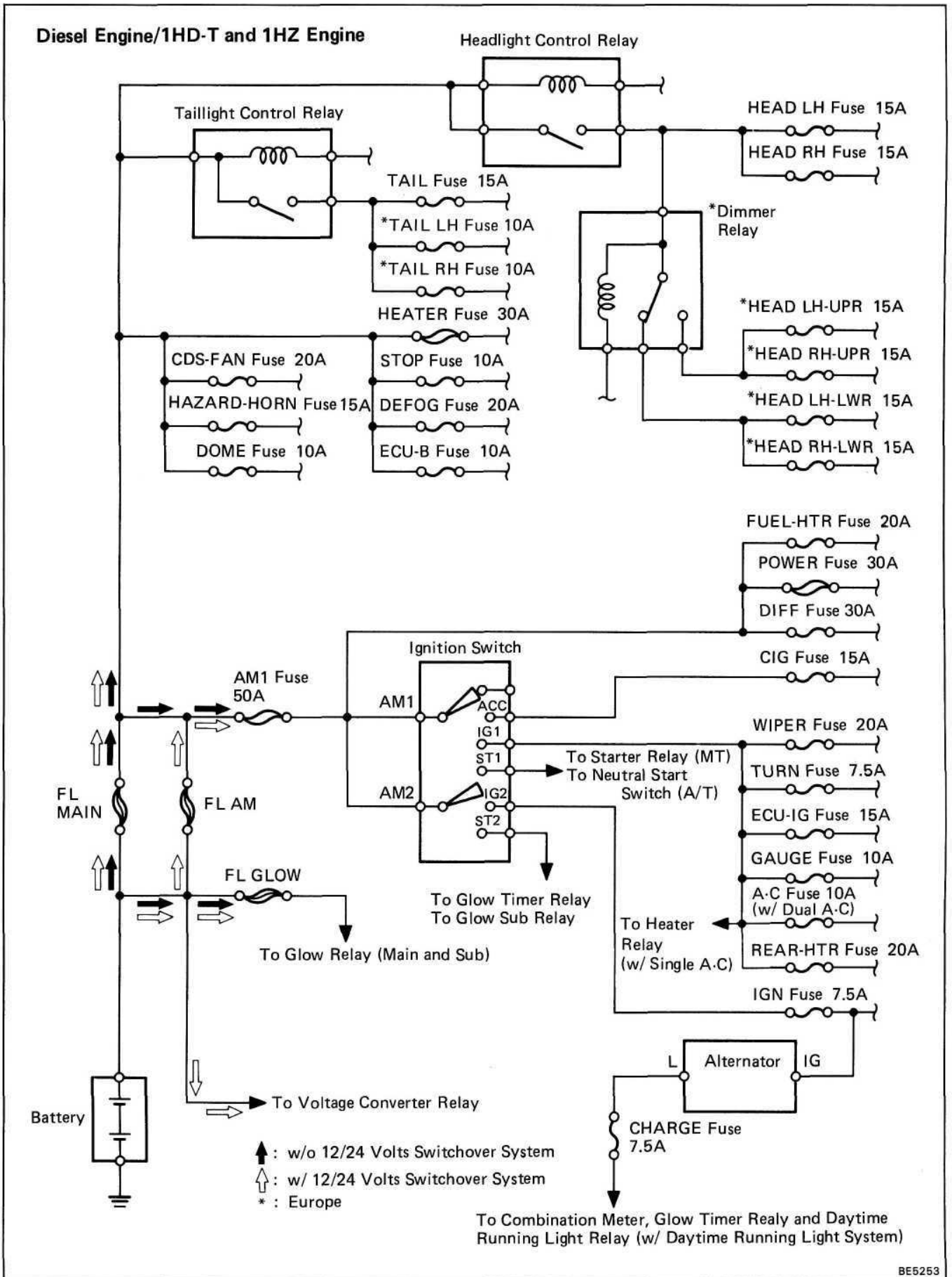

IGNITION SWITCH

Parts Location

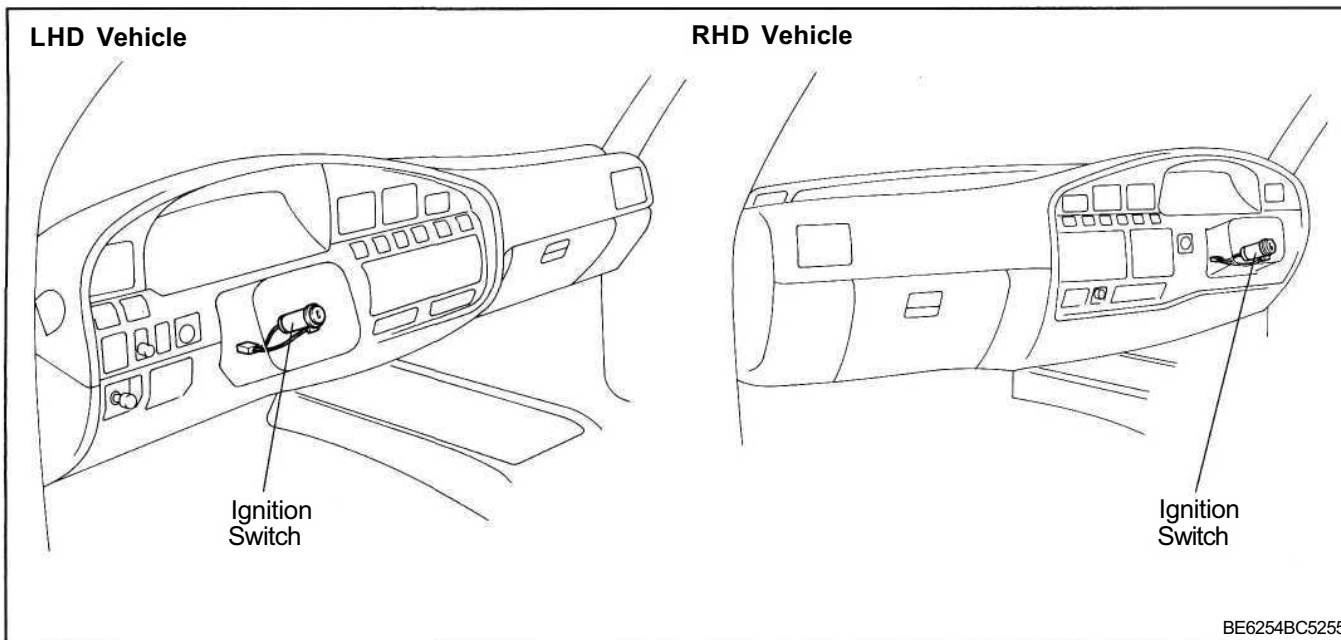

BE6254BC5255

Wiring and Connector Diagrams

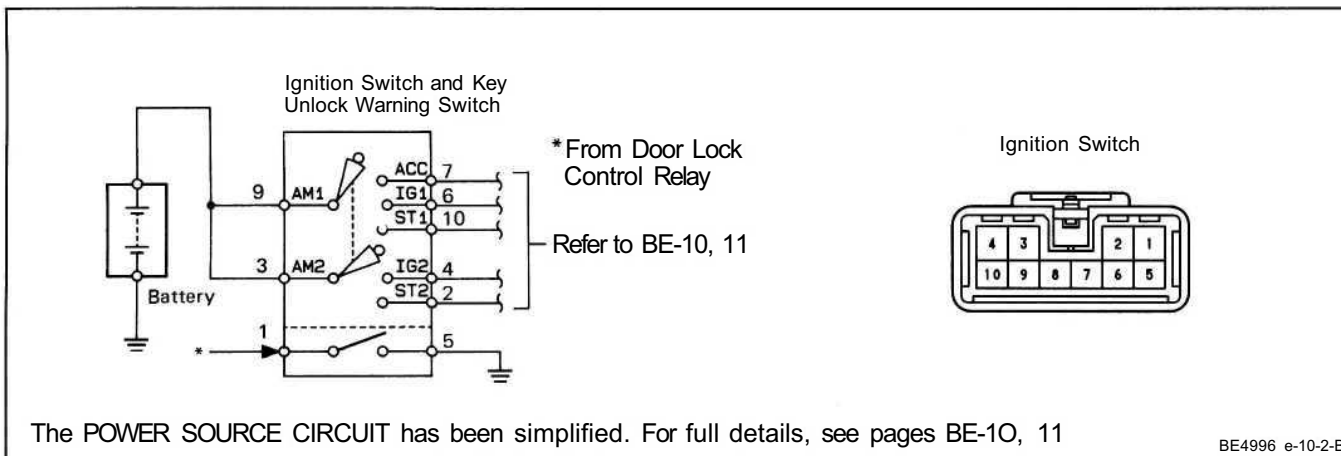

BE4996 e-10-2-B

Parts Inspection

Ignition System

INSPECT SWITCH (Ignition Switch/Continuity)

	Terminal	2	3	4	6	7	9	10
	Switch position							
	LOCK							
	ACC						○—○	
	ON		○—○	○—○	○—○	○—○	○—○	
START	○—○	○—○	○—○	○—○	○—○	○—○	○—○	

BE3582e-10-2-B

If continuity is not as specified, replace the switch.

Key Confine Prevention System

INSPECT SWITCHES

(Key Unlock Warning Switch/Continuity)

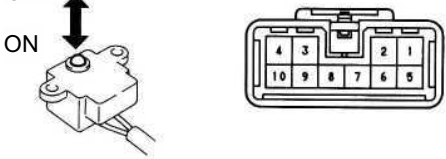
 <p style="text-align: right; margin-right: 20px;">BE2193 e-10-2-B</p>	Terminal		
	Switch position	1	5
	OFF (Ignition Key removed)		
ON (Ignition Key set)	○	○	

If continuity is not as specified, replace the switch.

LIGHTING SYSTEM

Parts Location

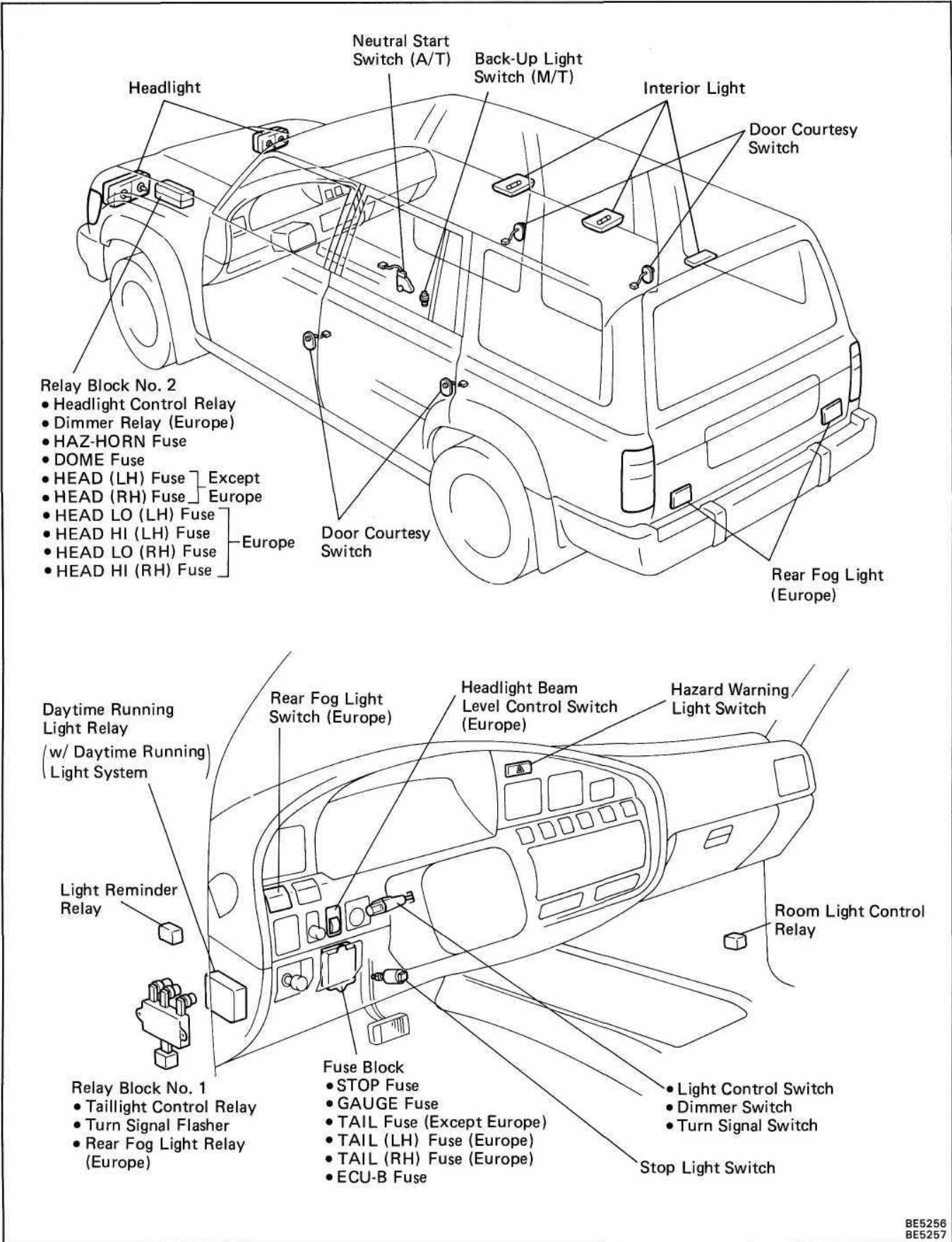

Wiring and Connector Diagrams (Headlight and Taillight System)

• Except Europe

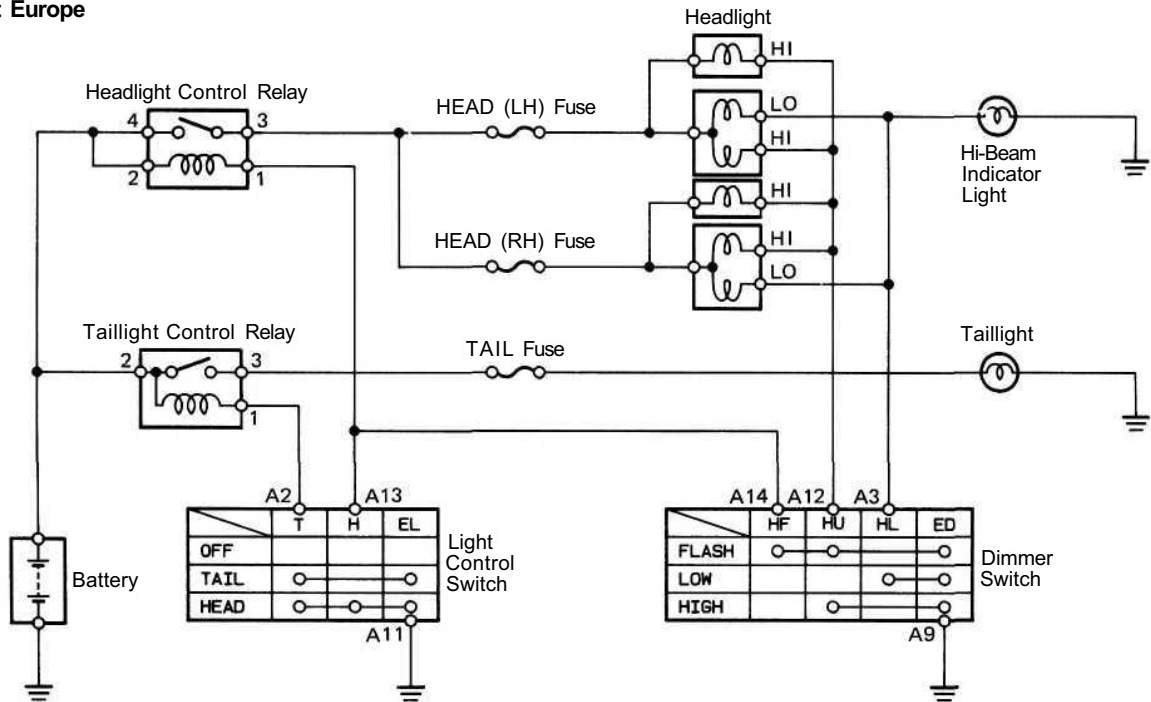

• Europe

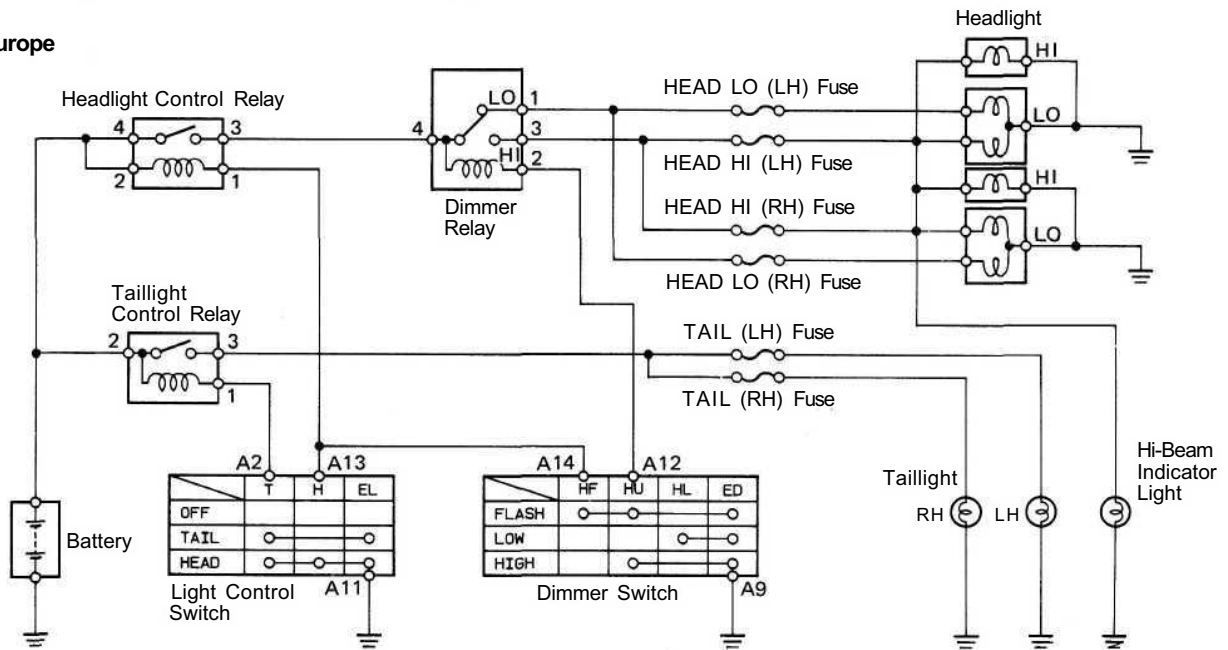

- Light Control Switch
- Dimmer Switch

Headlight Control Relay

Taillight Control Relay

Dimmer Relay

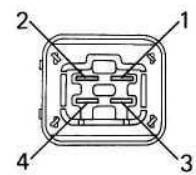
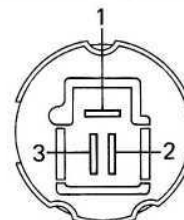
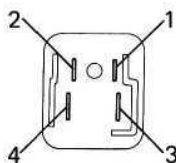
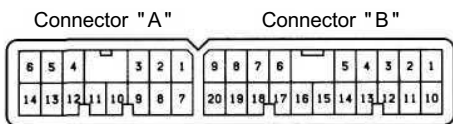

The POWER SOURCE CIRCUIT has been simplified. For full details, see pages BE-10, 11

• With Daytime Running Light System (with Rear Fog Light System)

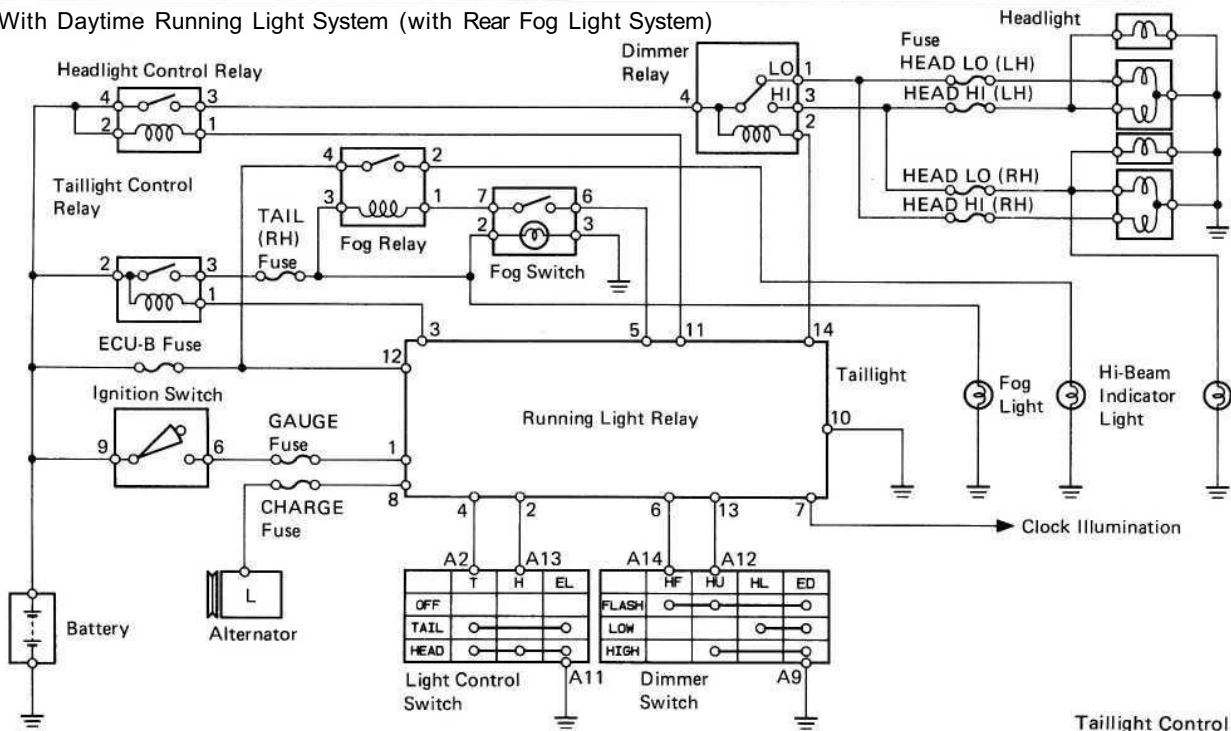

- Light Control Switch
- Dimmer Switch

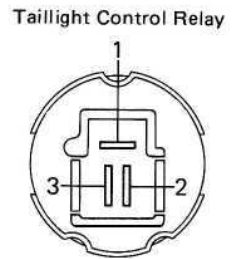
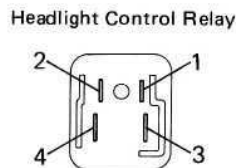
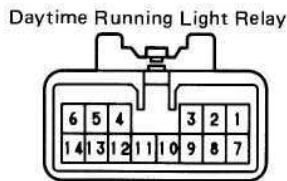
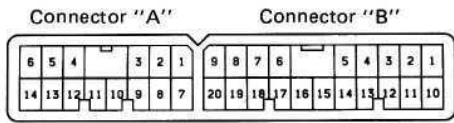

Rear Fog Switch

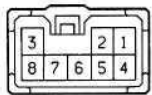

Dimmer Relay

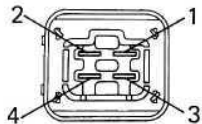

Rear Fog Relay

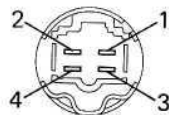

The POWER SOURCE CIRCUIT has been simplified. For full details, see pages BE-10, 11

BE5023
V-34-2 e-14-2-A BE1838 BE2763
S-8-2 BE1839 BE1647

(Headlight Beam Level Control System)

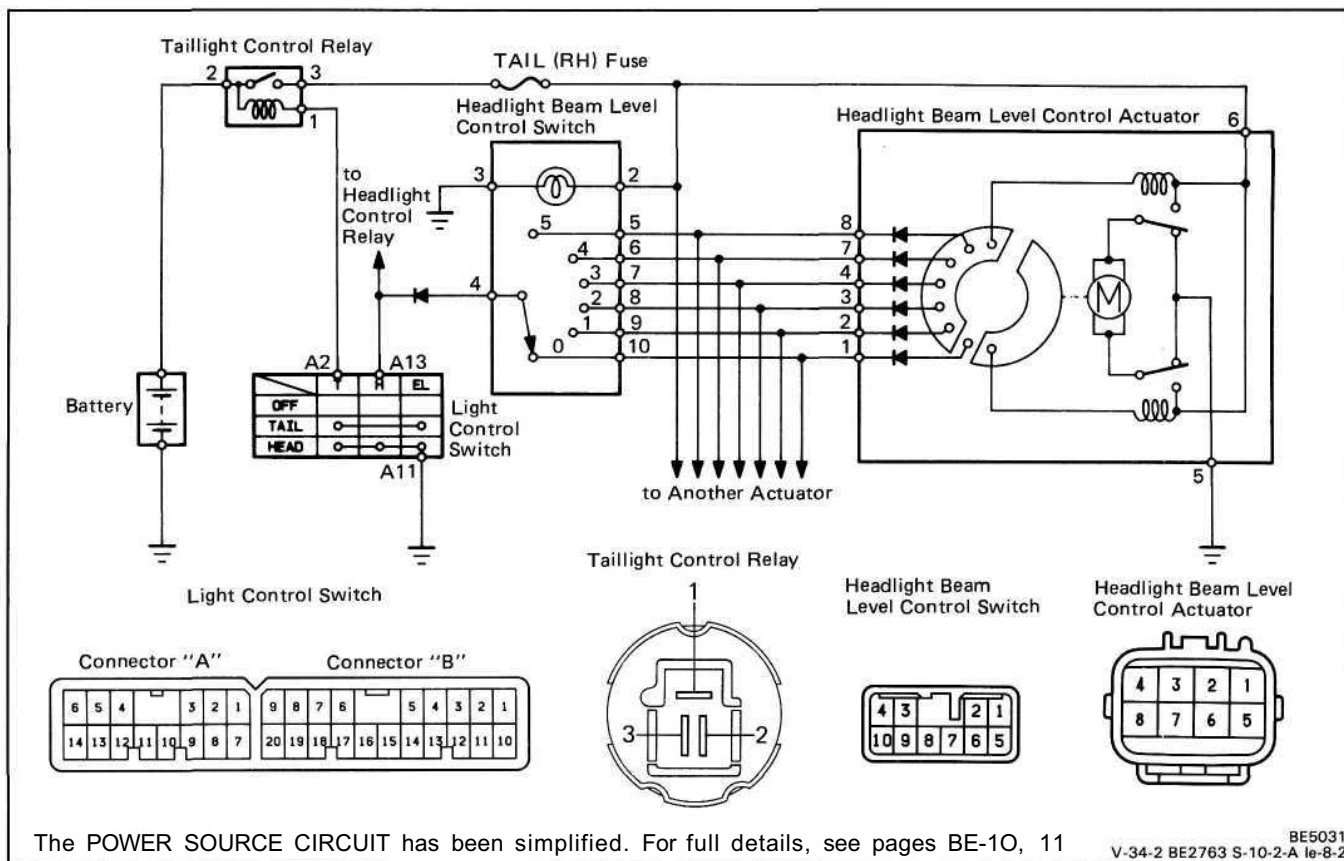

(Turn Signal and Hazard Warning System)

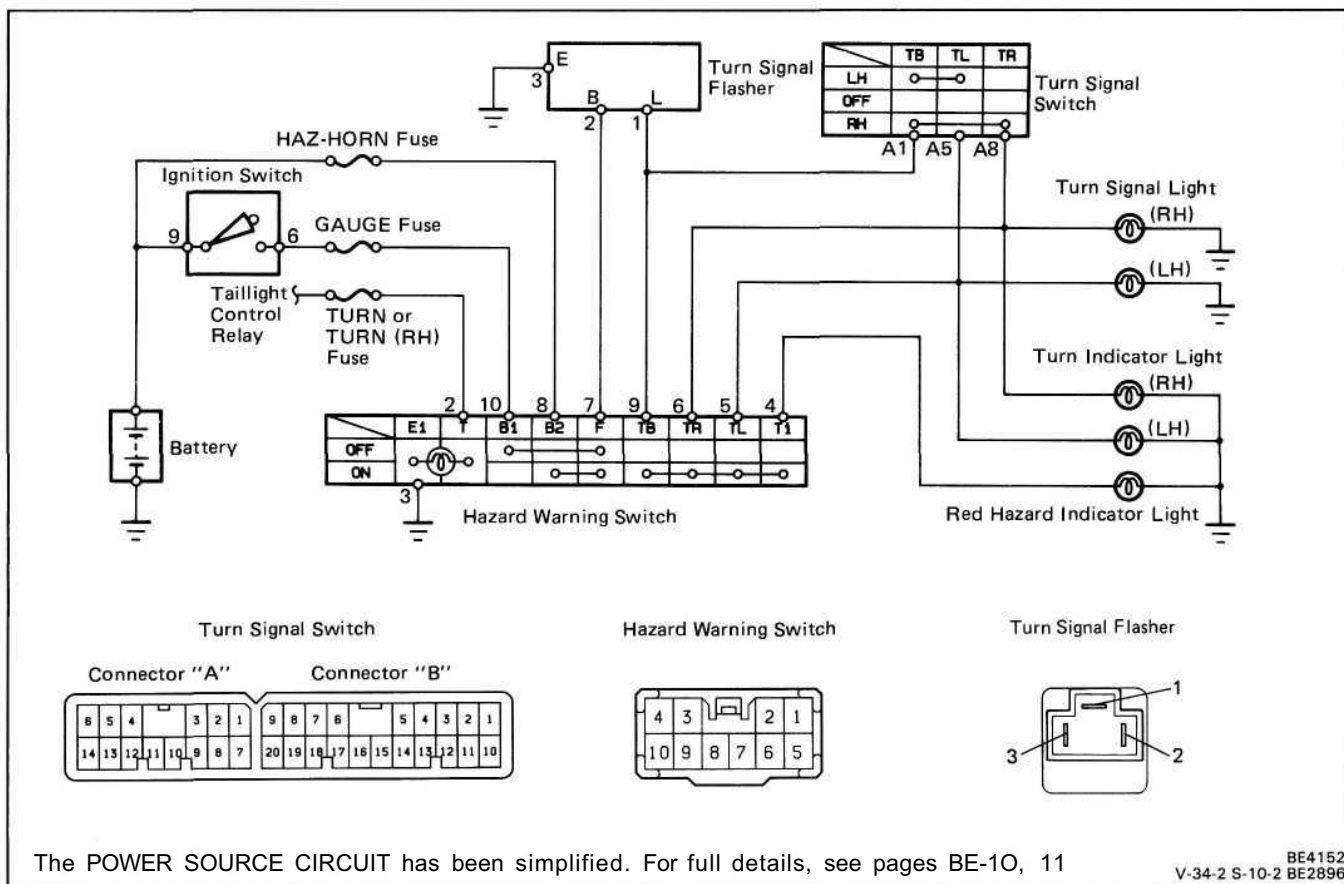

(Rear Fog Light System)

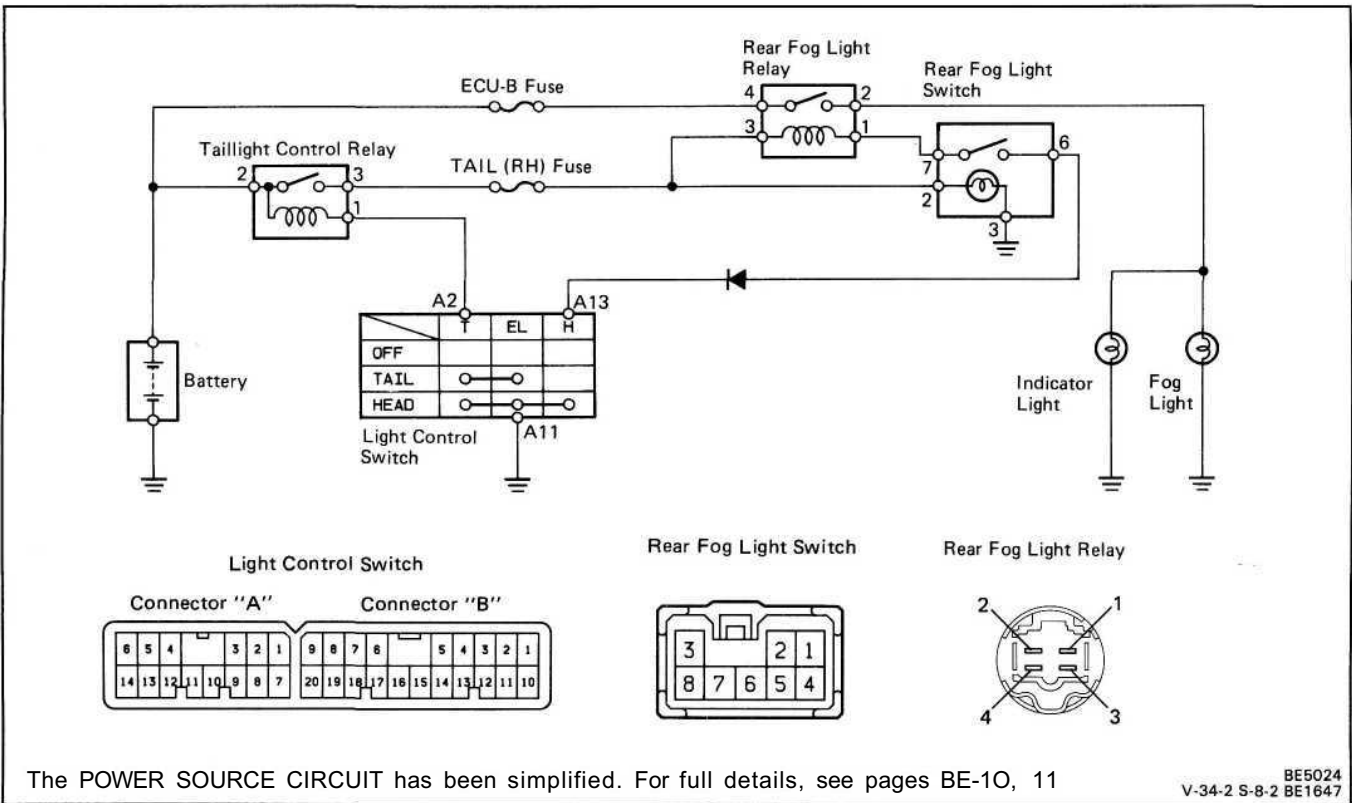

The POWER SOURCE CIRCUIT has been simplified. For full details, see pages BE-10, 11

BE5024
V-34-2 S-8-2 BE1647

(Lights-On Warning System)

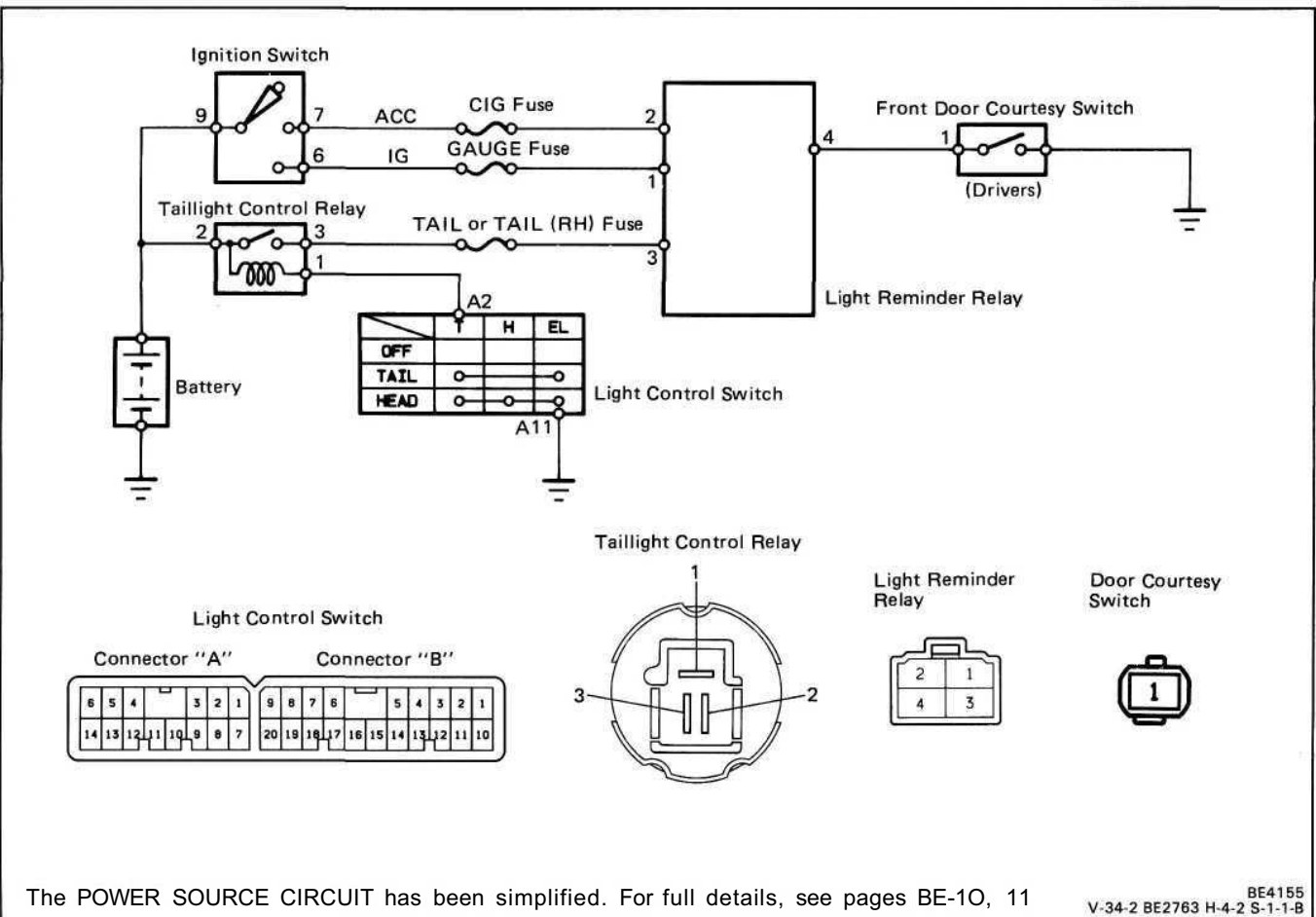

The POWER SOURCE CIRCUIT has been simplified. For full details, see pages BE-10, 11

BE4155
V-34-2 BE2763 H-4-2 S-1-1-B

(Illuminated Entry System)

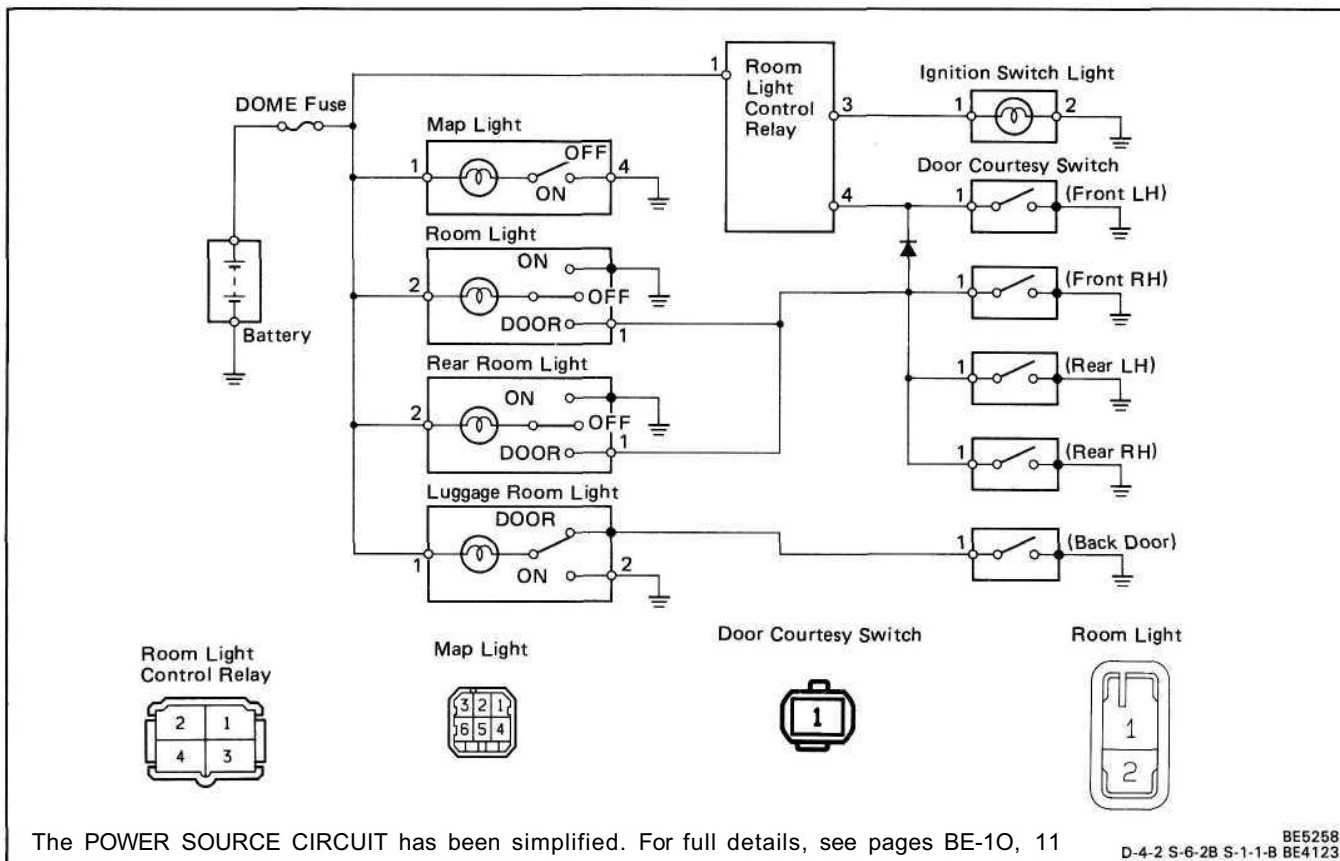

(Stop Light System)

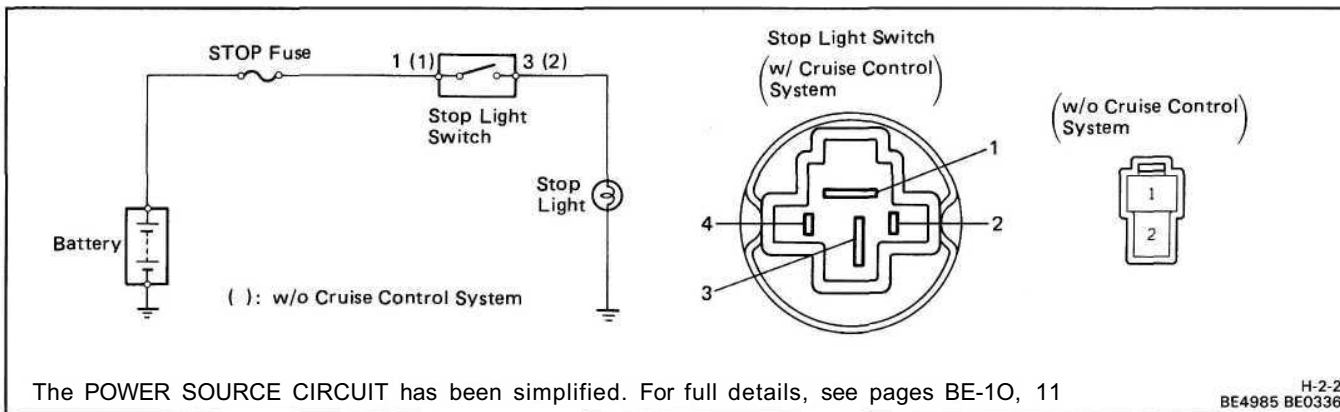

(Back-up Light System)

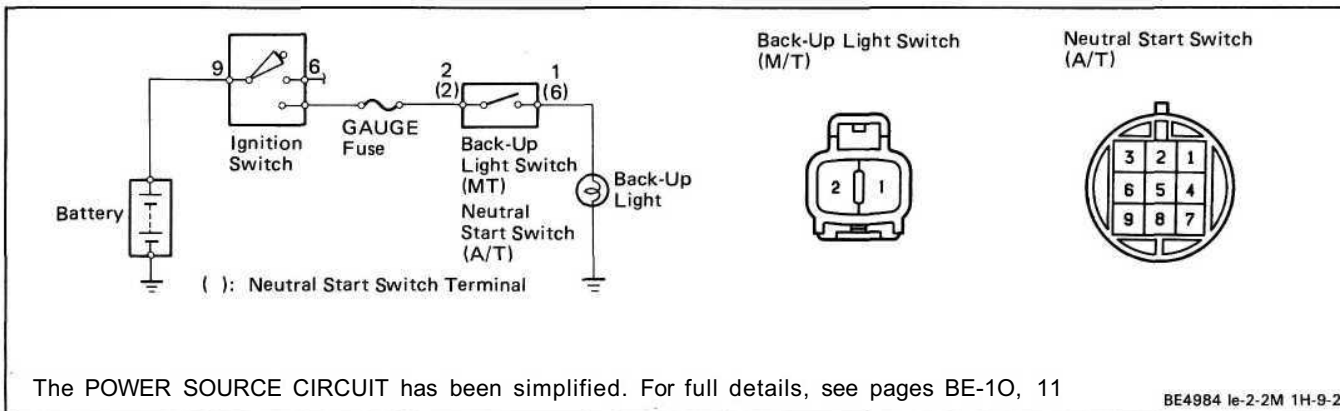

System Description

(Daytime Running Light System)

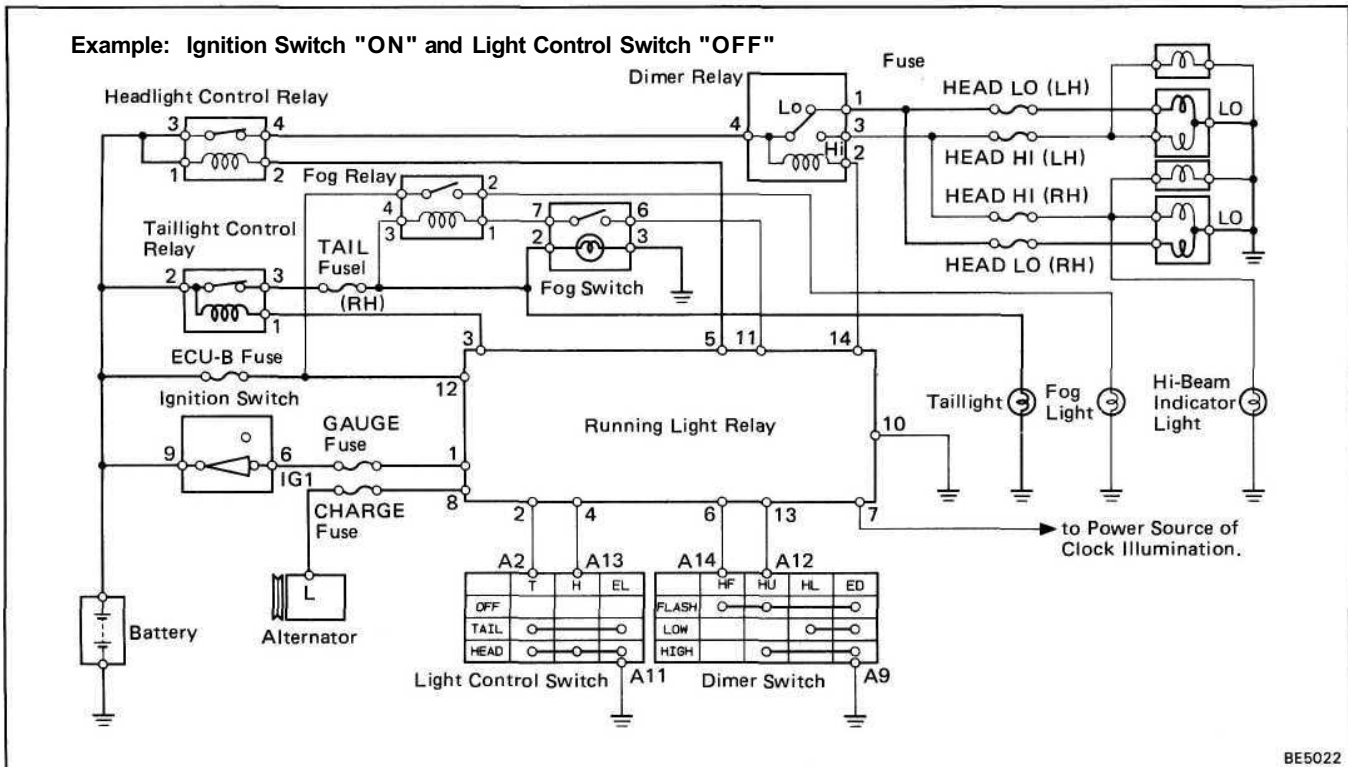

Standby Operation

- Current flows from the battery to terminal 12 of the Running Light Relay.
- When the engine is started, alternator voltage is applied from terminal L of the alternator to terminal 8 of the Running Light Relay.

Operation

1. IGNITION SWITCH "ON" AND LIGHT CONTROL SWITCH "OFF"

When the switches are set, current flows from the battery to terminal 1 of the Running Light Relay. Also, because continuity is made between terminal 3 of the Running Light Relay and ground, and terminal 5 of the Running Light Relay and ground, the Tailight control Relay and Headlight Control Relay are turned on. Then the taillights and headlights light up.

HINT: Because terminal 14 of the Running Light Relay is not grounded at all times, the Headlight Dimmer Relay is off, so the headlights light up at low beam.

2. IGNITION SWITCH "ON" AND LIGHT CONTROL SWITCH AT "TAIL"

When the switches are set, continuity is made between terminal 2 of the Running Light Relay and ground. Also, because continuity is made between terminal 3 of the Running Light Relay and ground at all times, the taillights light up.

(Fog Light): Also, because continuity is made between terminal 11 of the Running Light Relay and ground, the Fog Light Relay is turned on. Then the fog lights light up on standby.

3. IGNITION SWITCH "ON" AND LIGHT CONTROL SWITCH AT "HEAD"

When the switches are set, continuity is made between terminal 4 of the Running Light Relay and ground, and terminal 2 of the Running Light Relay and ground. Also, because continuity is made between terminal 5 of Running Light Relay and ground, and terminal 3 of the Running Light Relay and ground at all times, the taillights and headlights light up.

HINT: When the Headlight Dimmer Switch is set to "HIGH", continuity is made between terminal 13 of the Running Light Relay and ground. Also, because continuity is made between terminal 14 of the Running Light Relay and Ground, the Headlight Dimmer Relay is turned on. Then the headlights go on at high beam.

4. HEADLIGHT DIMMER SWITCH AT "FLASH"

When the switch is set, continuity is made between terminal 6 of the Running Light Relay and ground, and terminal 13 of the Running Light Relay and ground. Also, because the continuity is made between terminal 5 of the Running Light Relay and ground, and terminal 14 of the Running Light Relay and ground, the headlights flash.

Headlight Beam Level Control System

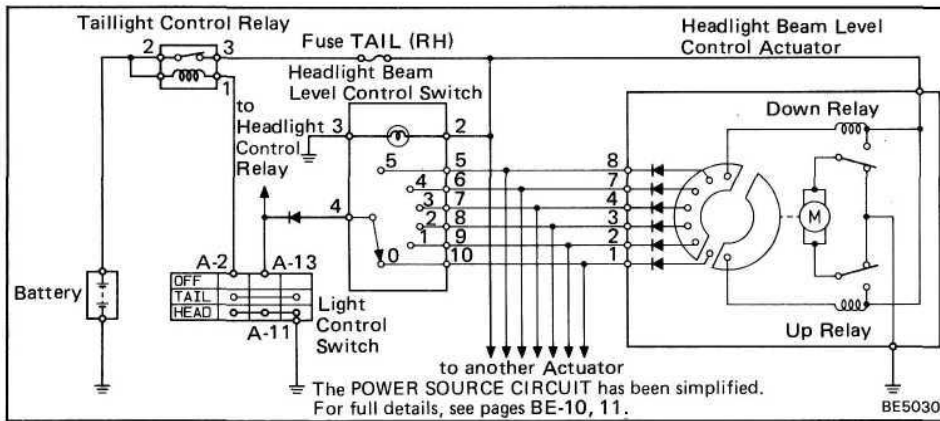

- Continuity always exists between terminal 5 of the Headlight Beam Level Control Actuator (here-after called "Actuator") and the ground.
- When the light Control Switch is turned to HEAD position, continuity is made between terminal 4 of the Headlight Beam Level Control Switch (hereafter called "Level Switch") and the ground through terminals

A-13 and A-11 of the Light Control Switch. Also, continuity is made between terminal 1 of the Taillight Control Relay and the ground through terminals A-2 and A-11 of the Light Control Switch, the Taillight Control Relay is turned on, then current flows from the battery to terminal 6 of the Actuator.

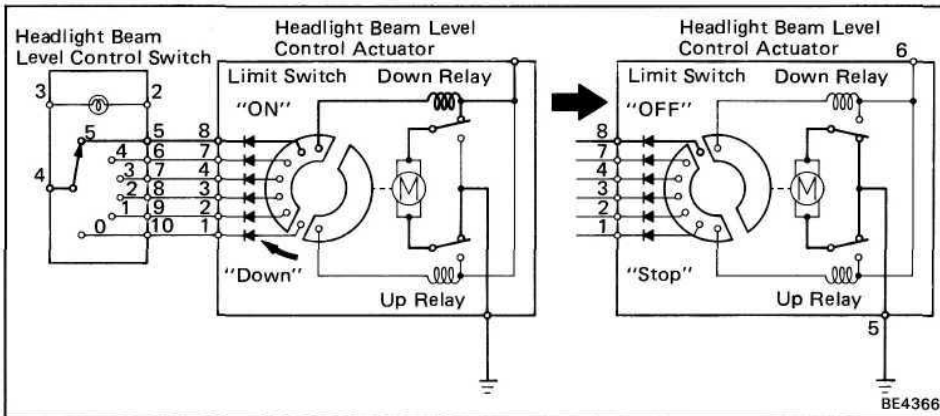

LEVEL SWITCH IN "5" POSITION

When the switch is set, Current flows from terminal 6 of Actuator → terminal 8 of the Level Switch → ground, and the Down Relay is activated. Then current flows from terminal 6 of the Actuator → Down Relay → Motor → Up Relay → terminal 5 of the Actuator → ground, and the Motor operates to lower the

headlight. When the headlights are lowered, the Limit Switch operates, so that continuity between terminals 6 and 8 of the Actuator is broken. As a result, the Down Relay is open and the headlights stay in level "5" position.

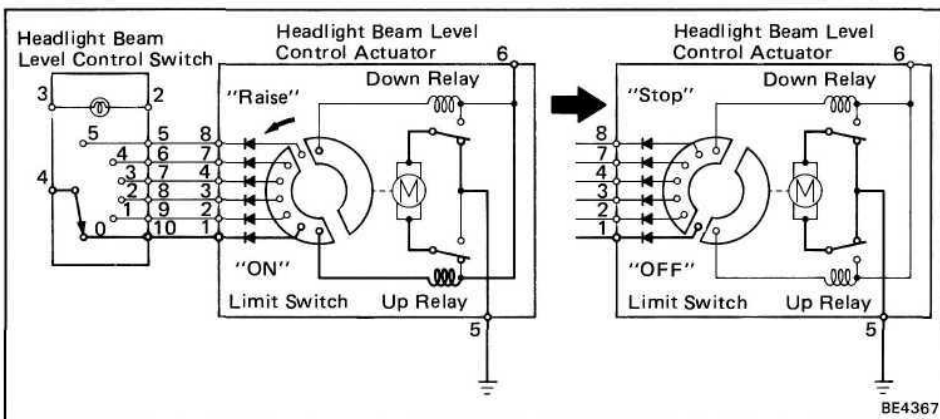

LEVEL SWITCH IN "0" POSITION

When the switch is set, current flows from terminal 6 of Actuator → terminal 1 of the Level Switch → ground, and the Up Relay is activated. Then current flows from terminal 6 of the Actuator → Up Relay → Motor → Down Relay → terminal 5 of the Actuator → ground, and the motor operates to raise the headlight.

When the headlights are raised, the Limit switch operates, so that continuity between terminals 6 and 1 of the Actuator is broken. As a result, the Up Relay is open and the headlights stay in level "0" position.

Troubleshooting

Problem	Possible cause	Remedy	Page
Only one light does not light up	Light bulb burned out Socket, wire or ground faulty	Check or replace the bulb Repair as necessary	BE-4, 5, 6
Headlight do not light up	HEAD fuse blown Headlight control relay faulty Light control switch faulty Dimmer switch faulty Wiring or ground faulty	Replace fuse and check for short Check relay Check switch Check switch Repair as necessary	BE-4, 6 BE-27 BE-27 BE-27
Head beam headlights or headlight flashers do not operate	Light control switch faulty Dimmer switch faulty Wiring or ground faulty	Check switch Check switch Repair as necessary	BE-27 BE-27
Tail, parking and license light do not light up	TAIL fuse blown Taillight control relay faulty Light control switch faulty Wiring or ground faulty	Replace fuse and check for short Check relay Check switch Repair as necessary	BE-4, 6 BE-27 BE-27
Stop lights do not light up	STOP fuse blown Stop light switch faulty Wiring or ground faulty	Replace fuse and check for short Adjust or check switch Repair as necessary	BE-4, 6 BE-33 BR-6
Stop lights stay on	Stop light switch faulty	Adjust or check switch	BE-33
Combination meter lights do not light up (taillights light up)	Light control rheostat faulty Wiring or ground faulty	Check rheostat Repair as necessary	BE-67
Turn signal does not flash on one side	Turn signal switch faulty Wiring or ground faulty	Check switch Repair as necessary	BE-27
Turn signals do not operate	TURN fuse blown Turn signal flasher faulty Turn signal switch faulty Hazard switch faulty Wiring or ground faulty	Replace fuse and check for short Check flasher Check switch Check switch Repair as necessary	BE-4, 6 BE-29 BE-27 BE-29
Hazard warning lights do not operate	HAZ-HORN fuse blown Turn signal flasher faulty Turn signal switch faulty Hazard switch faulty Wiring or ground faulty	Replace fuse and check for short Check flasher Check switch Check switch Repair as necessary	BE-4, 6 BE-29 BE-27 BE-29
Back-up light do not light up	GAUGE fuse blown Neutral switch faulty (A/T) Back-up light switch (M/T) Wiring or ground faulty	Replace fuse and check for short Check switch Check switch Repair as necessary	BE-4, 6 AT-28 MT-24

Troubleshooting (Cont'd)

Problem	Possible cause	Remedy	Page
Daytime running light system does not operate	TAIL (RH) fuse blown GAUGE fuse blown ECU-B fuse blown Daytime running light relay faulty Headlight control relay faulty Taillight control relay faulty Headlight dimmer relay faulty Ignition switch faulty Light control/dimmer switch faulty Wiring or ground faulty	Replace blown fuse and check for short Check relay Check relay Check relay Check relay Check switch Check switch Repair as necessary	BE-4, 6 BE-28 BE-27 BE-27 BE-27 BE-12 BE-27
Rear fog light system does not operate	ECU-B fuse blown TAIL fuse blown Rear fog light relay faulty Taillight control relay faulty Daytime Running Light Relay faulty (w/ Daytime Running Light System) Rear fog light switch faulty Light control switch faulty Wiring or ground faulty	Replace blown fuse and check for short Check relay Check relay Check relay Check switch Check switch Repair as necessary	BE-4, 6 BE-29 BE-27 BE-28 BE-29 BE-27
Illuminated entry system does not operate	DOME fuse blown Room light control relay faulty Door courtesy switch faulty Wiring or ground faulty	Replace fuse and check for short Check relay Check switch Repair as necessary	BE-4, 6 BE-32 BE-32
Headlight beam level control system does not operate	TAIL fuse blown Taillight control relay faulty Headlight beam level control actuator faulty Headlight beam level control switch faulty Light control switch faulty	Replace fuse and check for short Check relay Check actuator Check switch Check switch	BE-4, 6 BE-27 BE-30 BE-30 BE-27
Lights-on warning system does not operate	CIG fuse blown GAUGE fuse blown TAIL fuse blown Light reminder relay faulty Door courtesy switch faulty Wiring or ground faulty	Replace fuse and check for short Check relay Check switch Repair as necessary	BE-4, 6 BE-31 BE-31

Parts Adjustment

Adjustment of Headlight Aim

- Four-Rectangular Type

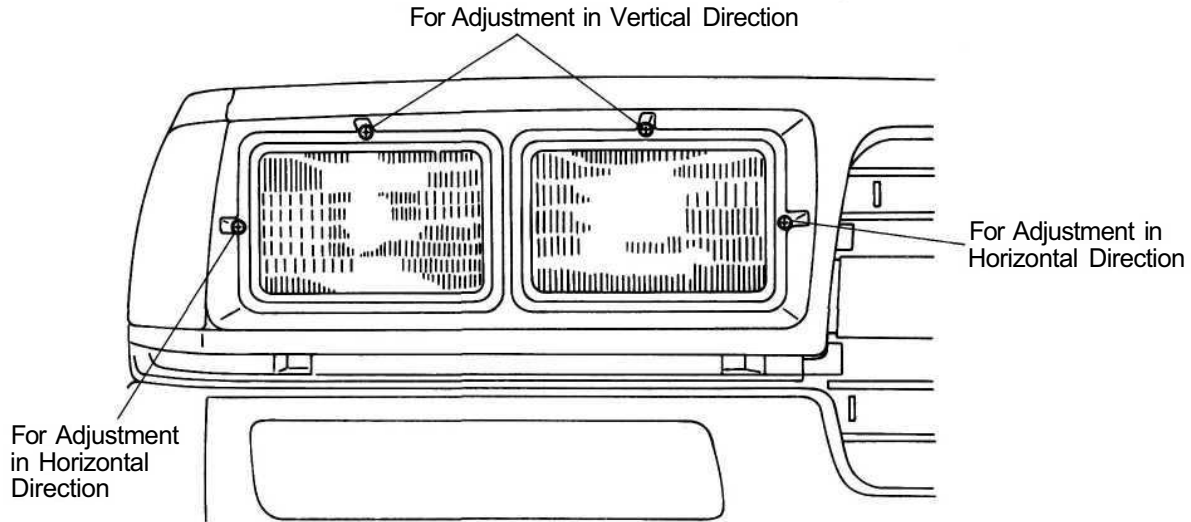

- Aero-Styled Type

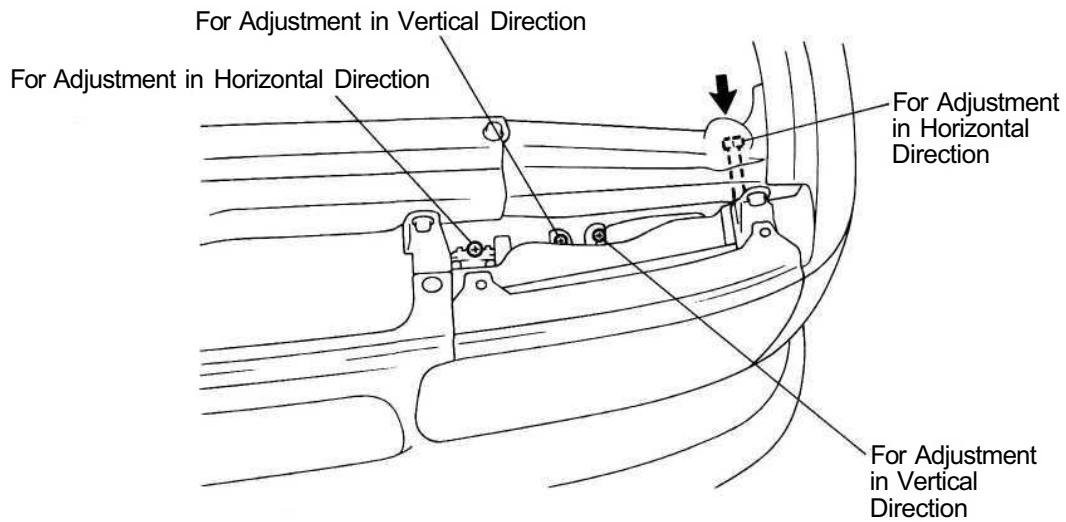

BE5204
BE5027

HINT: Before adjusting headlights equipped with a headlight beam level control system, first return the headlights to standard position by moving the control switch to "0" position.

Parts Replacement Components

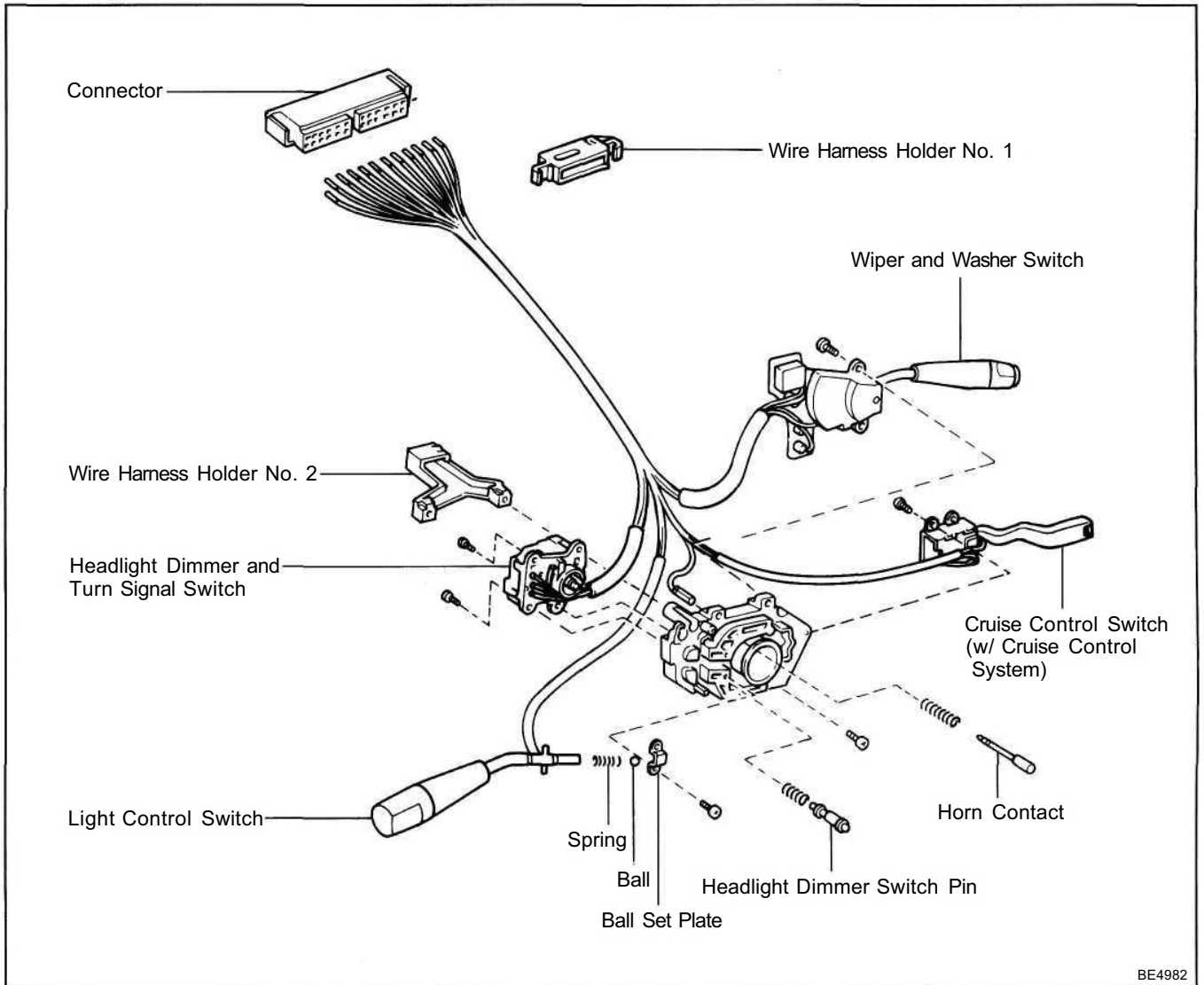

BE4982

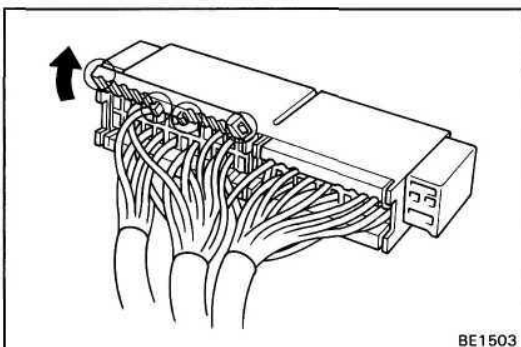

BE1503

Disassembly of Combination Switch

1. **REMOVE WIRE HARNESS CLAMP FROM WIRE HARNESS**
Pry loose two locking lugs and remove the clamp from the wire harness.
2. **REMOVE TERMINALS FROM CONNECTOR**
 - (a) Release four tabs and open the terminal cover.

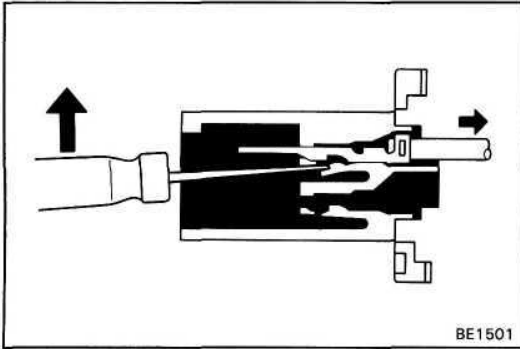

- (b) From the open end, insert a miniature screwdriver between the locking lug and terminal.
- (c) Pry down the locking lug with the screwdriver and pull the terminal out from the rear.

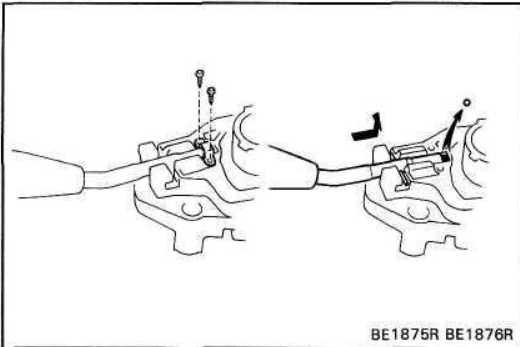

3. REMOVE LIGHT CONTROL SWITCH

- (a) Remove two screws and the ball set plate from the switch body.
- (b) Remove the ball and slide out the switch from the switch body with the spring.

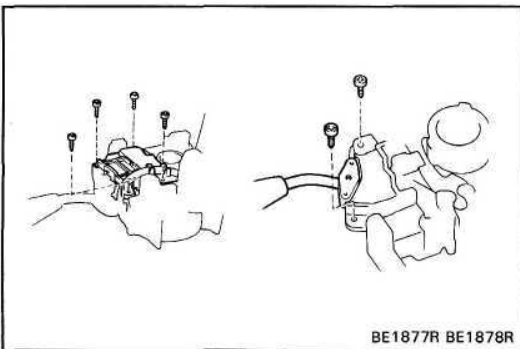

4. REMOVE HEADLIGHT DIMMER AND TURN SIGNAL SWITCH

Remove four screws and the switch from the switch body.

5. REMOVE WIPER AND WASHER SWITCH

Remove two screws and the switch from the switch body.

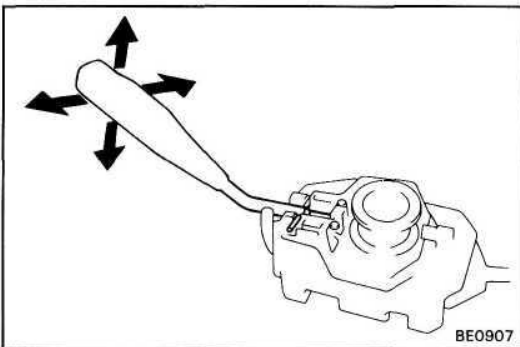

Assembly of Combination Switch

INSTALL PARTS OF COMBINATION SWITCH IN REVERSE SEQUENCE OF REMOVAL

HINT:

- After installing the switch to the switch body, insert that the switch operates in smoothly.
- Push in the terminal until it is securely locked in the connector lug.

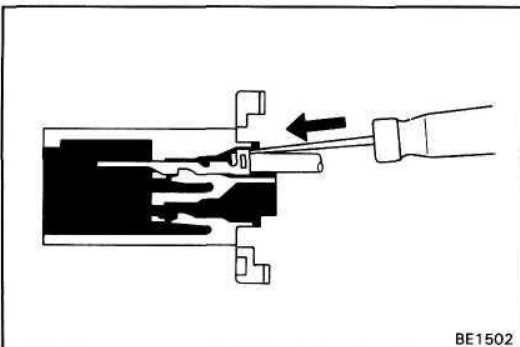

Reference: LHD Vehicles

Right Turn
Flash
Hi
Left Turn

Connector "A" Connector "B"

6	5	4	3	2	1	9	8	7	6	5	4	3	2	1
14	13	12	11	10	9	8	7	6	5	4	3	2	1	10

Reference: For RHD vehicles, the switch is always symmetrically opposite to LHD vehicles.

BE4164
V-34-2

Parts Inspection

Headlight and Taillight System

1. INSPECT COMBINATIN SWITCH (Light Control Switch/Continuity)

Terminal (Color) Switch position	A2 (W)	A11 (W)	A13 (R)
OFF			
TAIL	○	○	
HEAD	○	○	○

(Headlight Dimmer and Turn Signal Switch/Continuity)

Headlight Dimmer Switch

Terminal (Color) Switch position	A3 (R-G)	A9 (W-B)	A12 (Ft-Y)	A14 (R-W)
Flash		○	○	○
Low beam	○	○		
High beam		○	○	

Turn Signal Switch

Terminal (Color) Switch position	A1 (G-W)	A5 (G-B)	A8 (G-Y)
Left turn	○	○	
Neutral			
Right turn	○	○	○

If continuity is not as specified, replace the switch.

2. INSPECT RELAY

(Headlight Control Relay/Continuity)

Terminal	1	2	3	4
Condition				
Constant	○	○		
Apply battery voltage to terminals 1 and 2.			○	○

BE1838 BE1840

(Taillight Control Relay/Continuity)

Terminal	1	2	3
Condition			
Constant	○	○	
Apply battery voltage to terminals 1 and 2.		○	○

BE2763 BE2505

(Headlight Dimmer Relay/Continuity)

Terminal	1	2	3	4
Condition				
Constant	○	○	○	○
Apply battery voltage to terminals 2 and 4.		○	○	○

BE1839 BE1842

If continuity is not as specified, replace the relay.

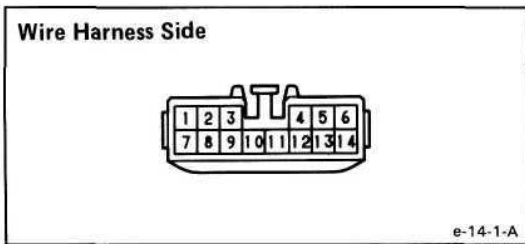

Daytime Running Light System

Inspect Daytime Running Light Relay

(Relay Circuit)

Disconnect the connector from the relay and inspect the connector on the wire harness side as shown in the chart.

Check for	Tester connection	Condition	Specified value	
Continuity	2 – Ground	Light control switch position	OFF	No continuity
			TAIL or HEAD	Continuity
	4 – Ground	Light control switch position	OFF or TAIL	No continuity
			HEAD	Continuity
	6 – Ground	Headlight dimmer switch position	Low beam or High beam	No continuity
			Flash	Continuity
7 – Ground 10 – Ground	Constant		Continuity	
13 – Ground	Headlight dimmer switch position	Low beam	No continuity	
		High beam or Flash	Continuity	
Voltage	1 – Ground	Ignition switch position	LOCK or ACC	No voltage
			ON	Battery voltage
	3 – Ground 5 – Ground	Constant		Battery voltage
	8 – Ground	Engine condition	Stop	No voltage
			Running	Battery voltage
	11 – Ground	Constant		No voltage
		Ground terminal 3		Battery voltage
	12 – Ground	Constant		Battery voltage
14 – Ground	Constant		No voltage	
	Ground terminal 5		Battery voltage	

If circuit is as specified, inspect relay operation.

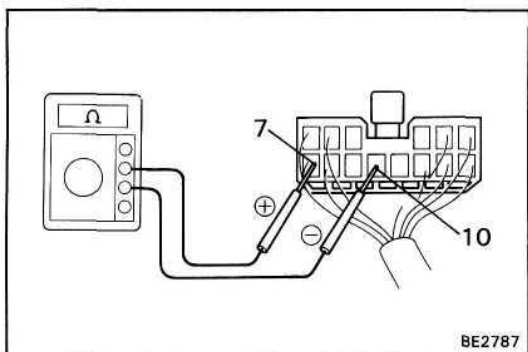

(Relay Operation)

- (a) Connect the positive (+) lead from the voltmeter to terminal 7 and negative (—) lead to terminal 10.
- (b) Check that there is battery voltage with light control switch is turned on.

If operation is not as specified, replace the relay.

Rear Fog Light System

1. INSPECT SWITCH (Continuity)

Terminal Switch position	6	7	Illumination	
			2	3
OFF				
ON				

BE5028 S-8-2

If continuity is not as specified, replace the switch.

2. INSPECT RELAY (Rear Fog Light Relay/Continuity)

Terminal	1	2	3	4
Condition				
Constant				
Apply battery voltage to terminals 1 and 3.				

BE1647 BE1840

If continuity is not as specified, replace the relay.

Turn Signal and Hazard Warning System

1. INSPECT SWITCHES (Turn Signal Switch/Continuity)

See Headlight dimmer and Turn Signal Switch on page BE-27.

(Hazard Warning Switch/Continuity)

Terminal Switch position	4	5	6	7	8	9	10	Illumination	
								2	3
OFF									
ON									

BE2415 S-10-2

If continuity is not as specified, replace the switch.

2. INSPECT TURN SIGNAL FLASHER (Operation)

- Connect the positive (+) lead from the battery to terminal 2 and the negative (-) lead to terminal 3.
- Connect the two turn signal light bulbs parallel to each other to terminals 1 and 3, check that the bulbs flash.

HINT: The turn signal lights should flash 60 to 120 times per minute.

If one of the front or rear turn signal lights has an open circuit, the number of flashers will be more than 140 per minute.

If operation is not as specified, replace the flasher.

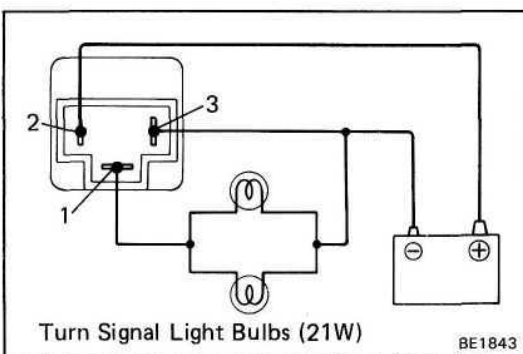

Headlight Beam Level Control System

1. INSPECT SWITCH
(Continuity)

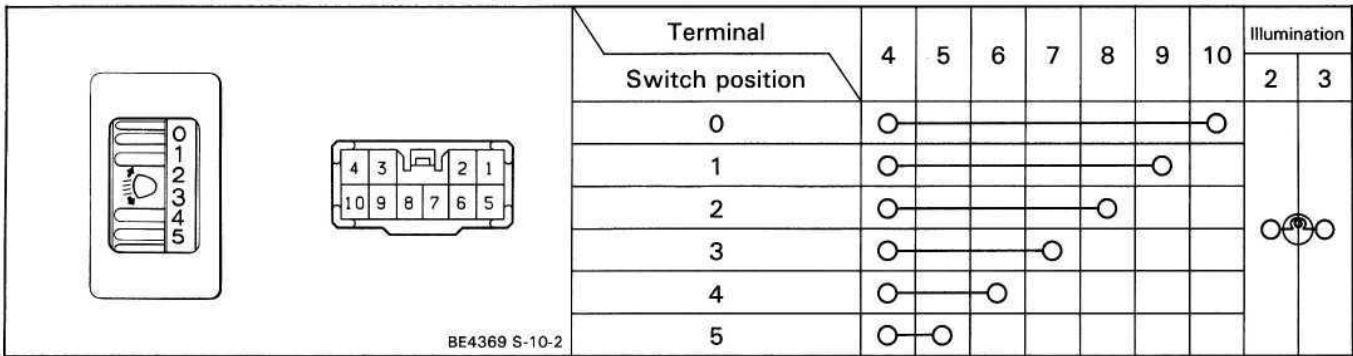

If continuity is not as specified, replace the switch.

2. INSPECT ACTUATOR

- (a) Connect the positive (+) lead from the battery to terminal 6 and the negative (—) lead to terminal 5.
- (b) Ground each terminal and check that each mode operates as shown in the chart and illustration.

Terminal	Headlight Beam Level
1 – ground	"0"
2 – ground	"1"
3 – ground	"2"
4 – ground	"3"
7 – ground	"4"
8 – ground	"5"

If operation is not as specified, replace the actuator.

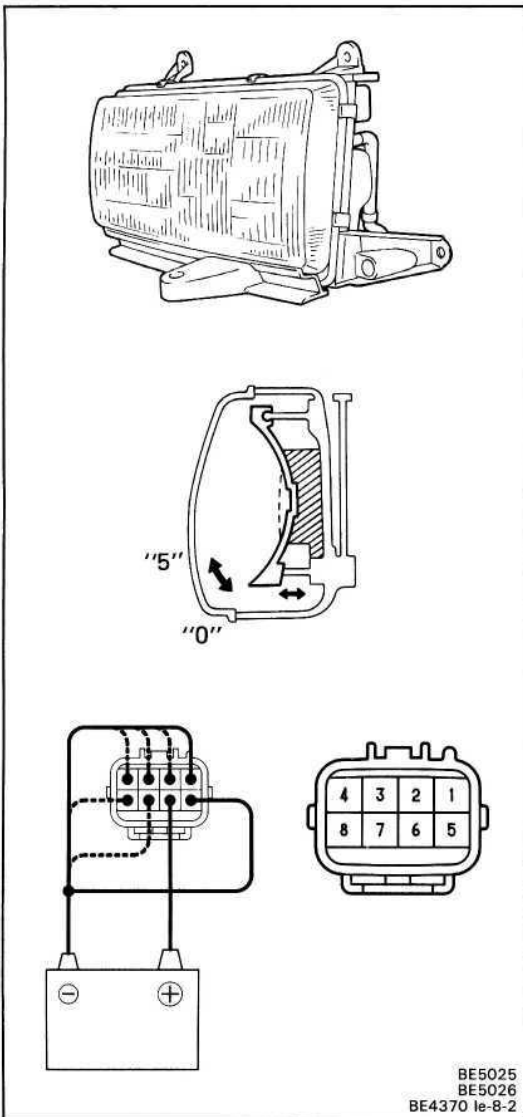

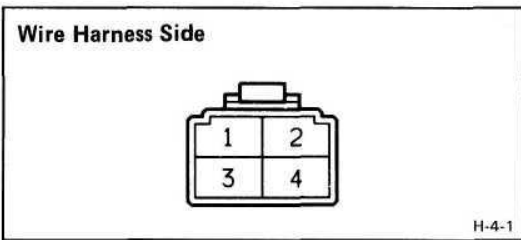
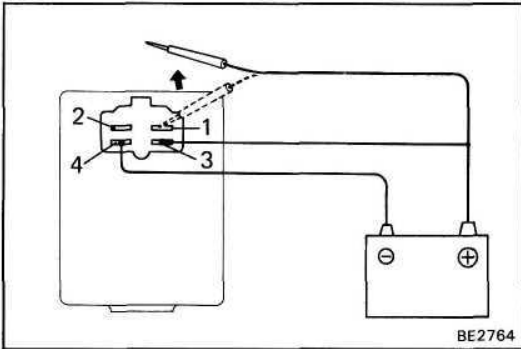
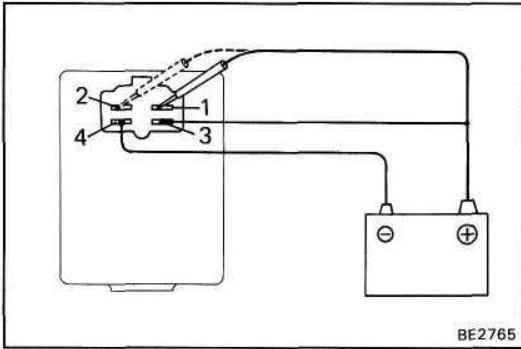

Lights-On Warning System

1. INSPECT DRIVER'S DOOR COURTESY SWITCH

See step 2 of Open Door Warning System on page BE-64.

2. INSPECT LIGHT REMINDER RELAY (Operation)

- (a) Connect the positive (+) lead from the battery to terminal 3 and the negative (-) lead to terminal 4.
- (b) Check that the buzzer does not sound when connected terminal 1 or 2 from the positive (+) lead.
- (c) Check that the buzzer sounds when disconnecting terminal 1 or 2 from the positive (+) lead.

If operation is not as specified, replace the relay.

(Relay Circuit)

Disconnect the connector from the relay and inspect the connector on the wire harness side as shown in the chart.

Check for	Tester connection	Condition		Specified value
Continuity	4 - Ground	Driver's door position	Closed (Courtesy switch OFF)	No continuity
			Opened (Courtesy switch ON)	Continuity
Voltage	1 - Ground	Ignition switch position	LOCK or ACC	No voltage
			ON	Battery voltage
	2 - Ground	Ignition switch position	LOCK	No voltage
			ACC or ON	Battery voltage
	3 - Ground	Light control Switch	OFF	No voltage
			TAIL or HEAD	Battery voltage

If circuit is as specified, replace the relay.

If circuit is not as specified, refer to BE-18 wiring diagram and inspect the circuits connected to other parts.

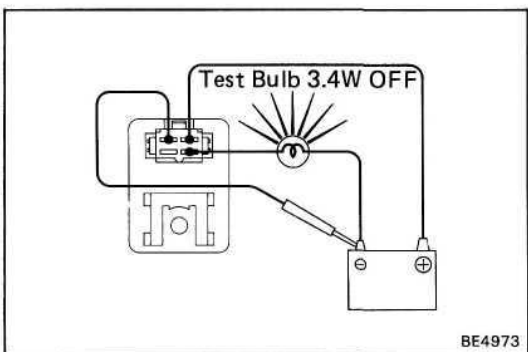
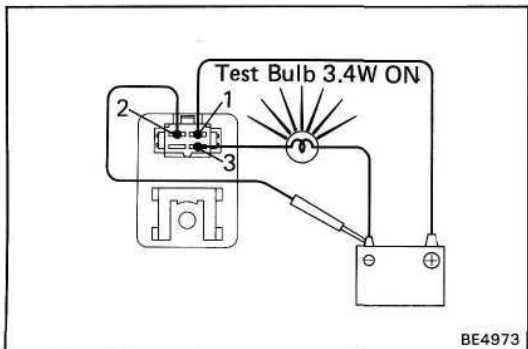

Illuminated Entry System

1. INSPECT FRONT DOOR COURTESY SWITCH

See step 2 of Open Door Warning System on page BE-64.

2. INSPECT ROOM LIGHT CONTROL RELAY (Operation)

- (a) Connect the positive (+) lead from the battery to terminal 1. Connect the negative (—) lead to terminal 2.
- (b) Connect a 3.4 W bulb between terminal 3 and the battery negative (—), and then check that the bulb lights.
- (c) Disconnect the negative (—) lead from the battery, and check that the bulb goes out approx. 5 seconds later as shown in the chart.

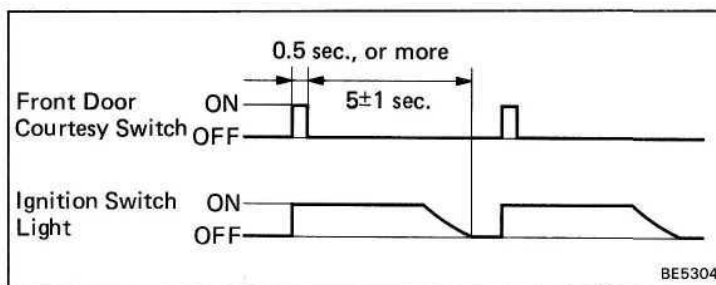

If operation is not as specified, replace the relay.

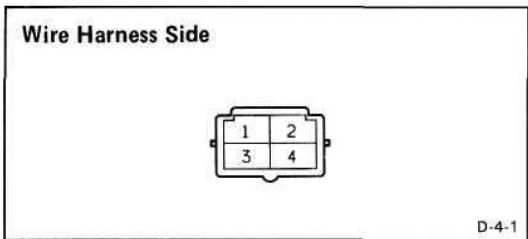

(Relay Circuit)

Disconnect the connector from the relay and inspect the connector on the wire harness side as shown in the chart.

Check for	Tester connection	Condition	Specified value	
Continuity	3 — Ground	Constant	Continuity	
	4 — Ground	Driver's door position	Closed (Courtesy switch OFF)	No continuity
			Open (Courtesy switch ON)	Continuity
Voltage	1 — Ground	Constant	Battery voltage	

If circuit is as specified, replace the relay.

If circuit is not as specified, refer to BE-19 wiring diagram and inspect the circuits to other parts.

Stop light System

**INSPECT SWITCH
(Stop Light Switch/Continuity)**

	Terminals				
	Switch position	1(1)	2	3(2)	4
	Switch pin free (Brake pedal depressed)	○		○	
Switch pin pushed in (Brake pedal released)		○		○	

() : w/o Cruise Control System

If continuity is not as specified, replace the switch.

Back-up Light System

INSPECT SWITCHES

(Neutral Start Switch)

See page AT-28.

(Back-up Light Switch)

See page MT-24.

HEADLIGHT CLEANER SYSTEM

Parts Location

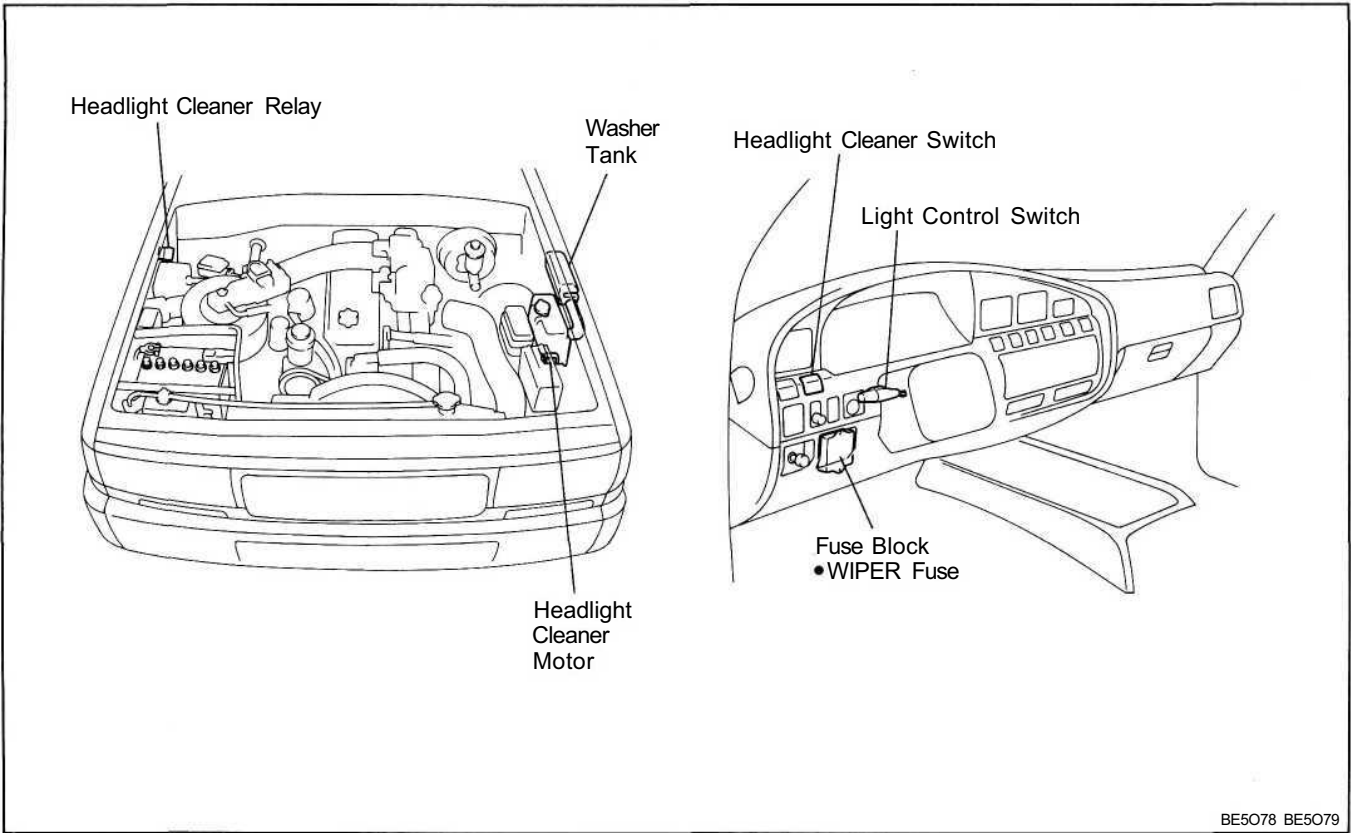

BE5078 BE5079

Wiring and Connector Diagrams

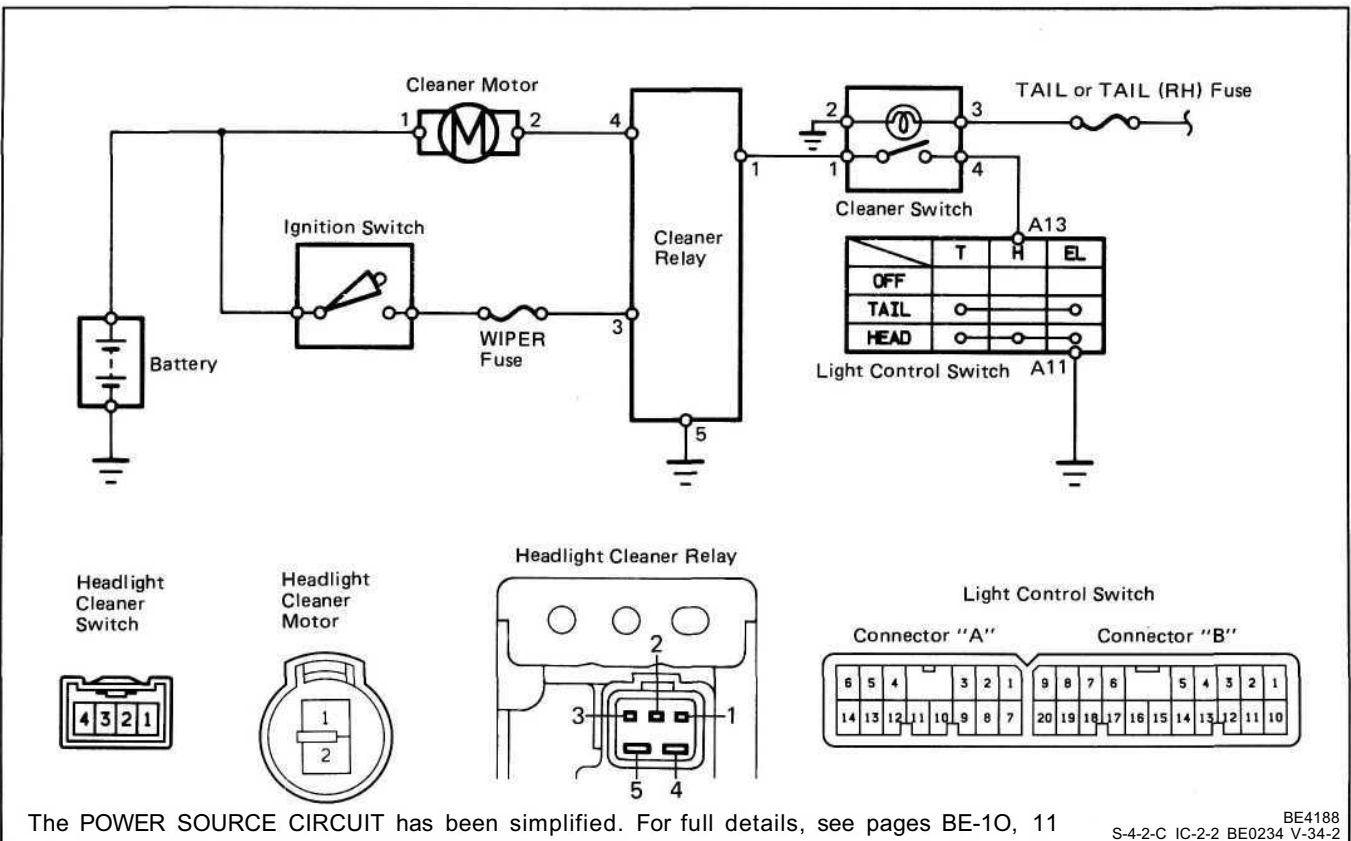

Troubleshooting

Problem	Possible cause	Remedy	Page
Headlight cleaner do not operate	WIPER fuse blown	Replace fuse and check for short	BE-4, 6
	Cleaner hose or nozzle clogged	Repair as necessary	
	Cleaner motor faulty	Check motor	BE-35
	Cleaner switch faulty	Check switch	BE-35
	Wiring or ground faulty	Repair as necessary	

Parts Inspection

1. INSPECT SWITCH (Continuity)

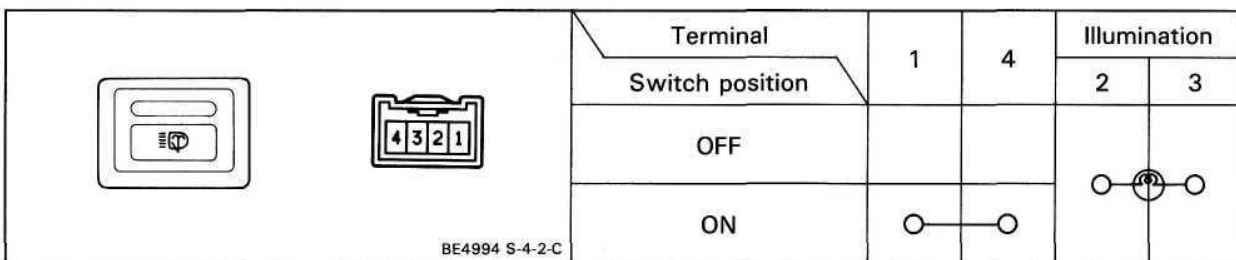

If continuity is not as specified, replace the switch.

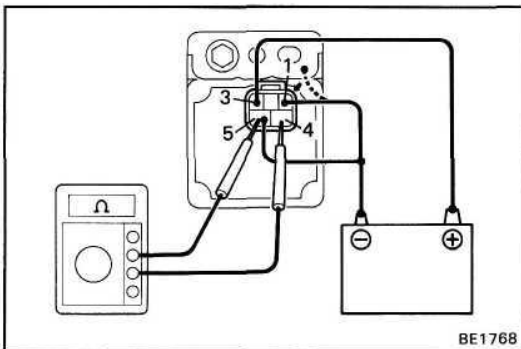

2. INSPECT HEADLIGHT CLEANER RELAY

- Check that there is no continuity between terminals 4 and 5.
- Connect the positive (+) lead from the battery to terminal 3 and the negative (-) lead to terminal 5.
- Connect the negative (-) lead from the battery to terminal 1, check that there is continuity between terminals 4 and 5 for 0.40 — 0.58 sec, then there is no continuity.

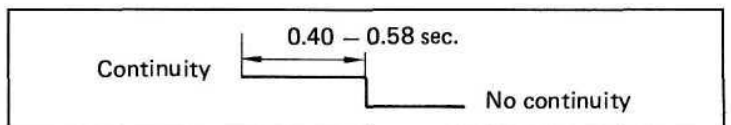

If operation is not as specified, replace the relay.

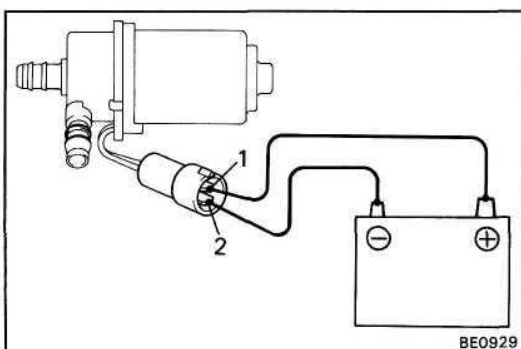

3. INSPECT HEADLIGHT CLEANER MOTOR

Connect the positive (+) lead from the battery to terminal 1 and the negative (-) lead to terminal 2, check that the motor operates.

NOTICE: These test must be performed quickly (within 3 — 5 seconds) to prevent the coil from burning out.

If operation is not as specified, replace the motor.

WIPER AND WASHER SYSTEM

Parts Location

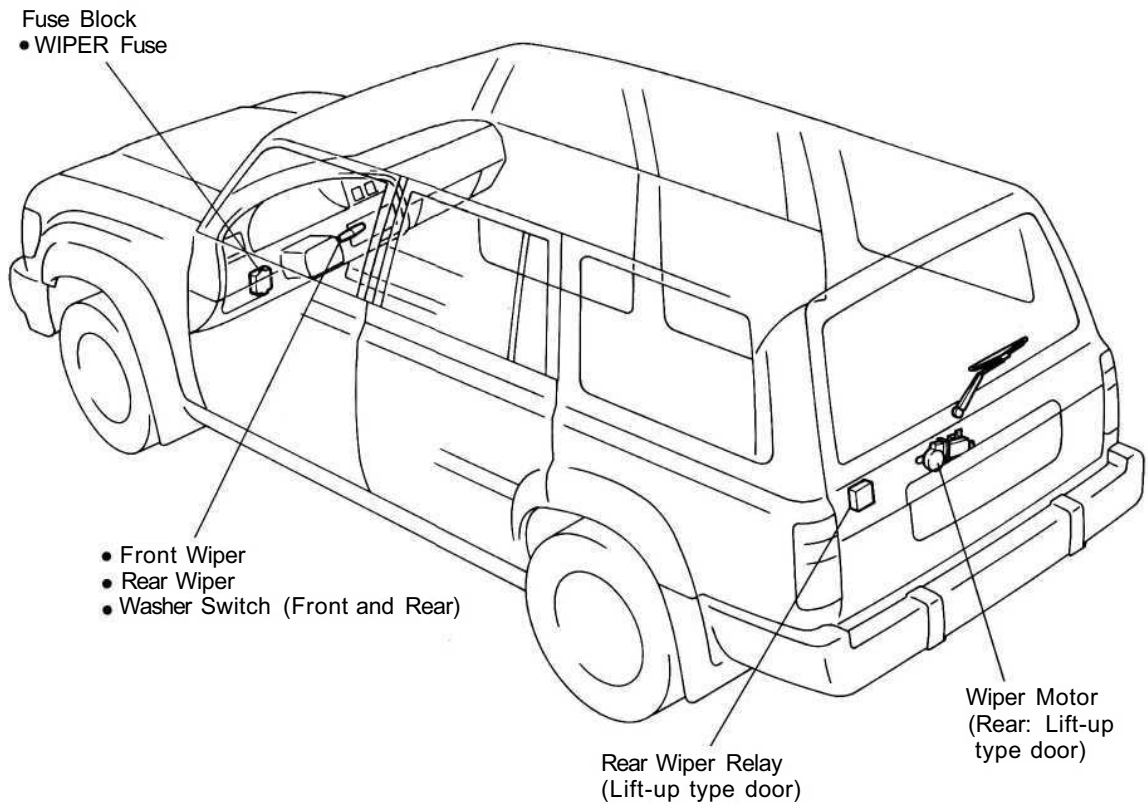
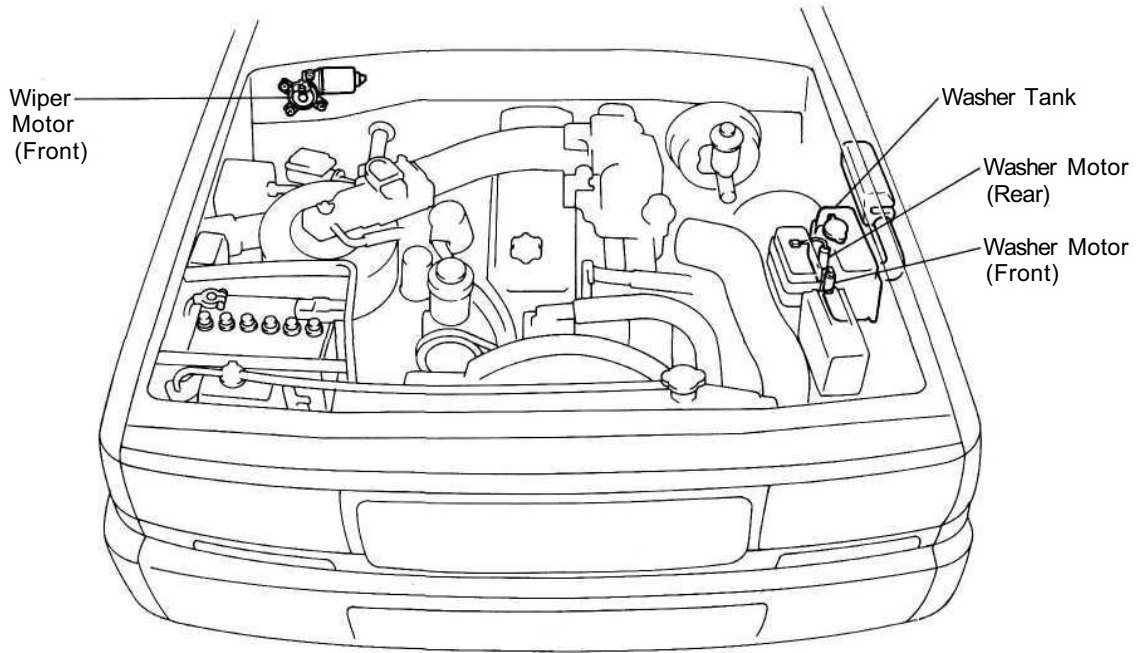

Parts Location (Cont'd)

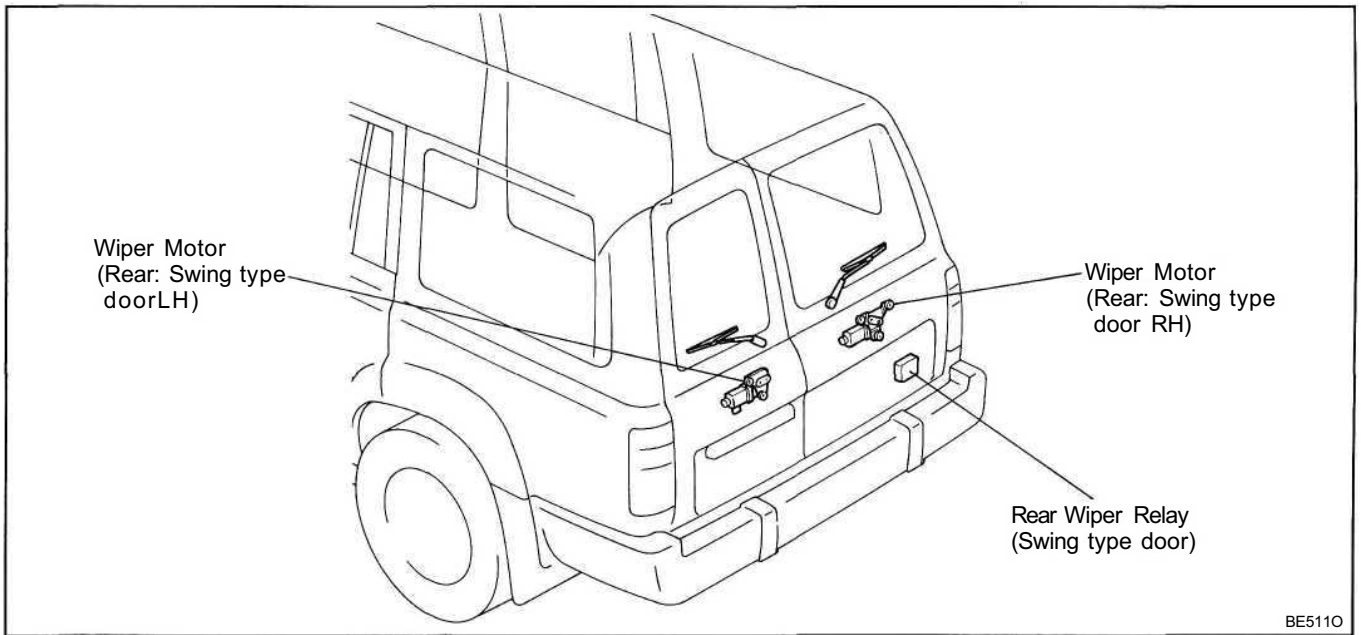

Wiring and Connector Diagrams (Front: Mist Type)

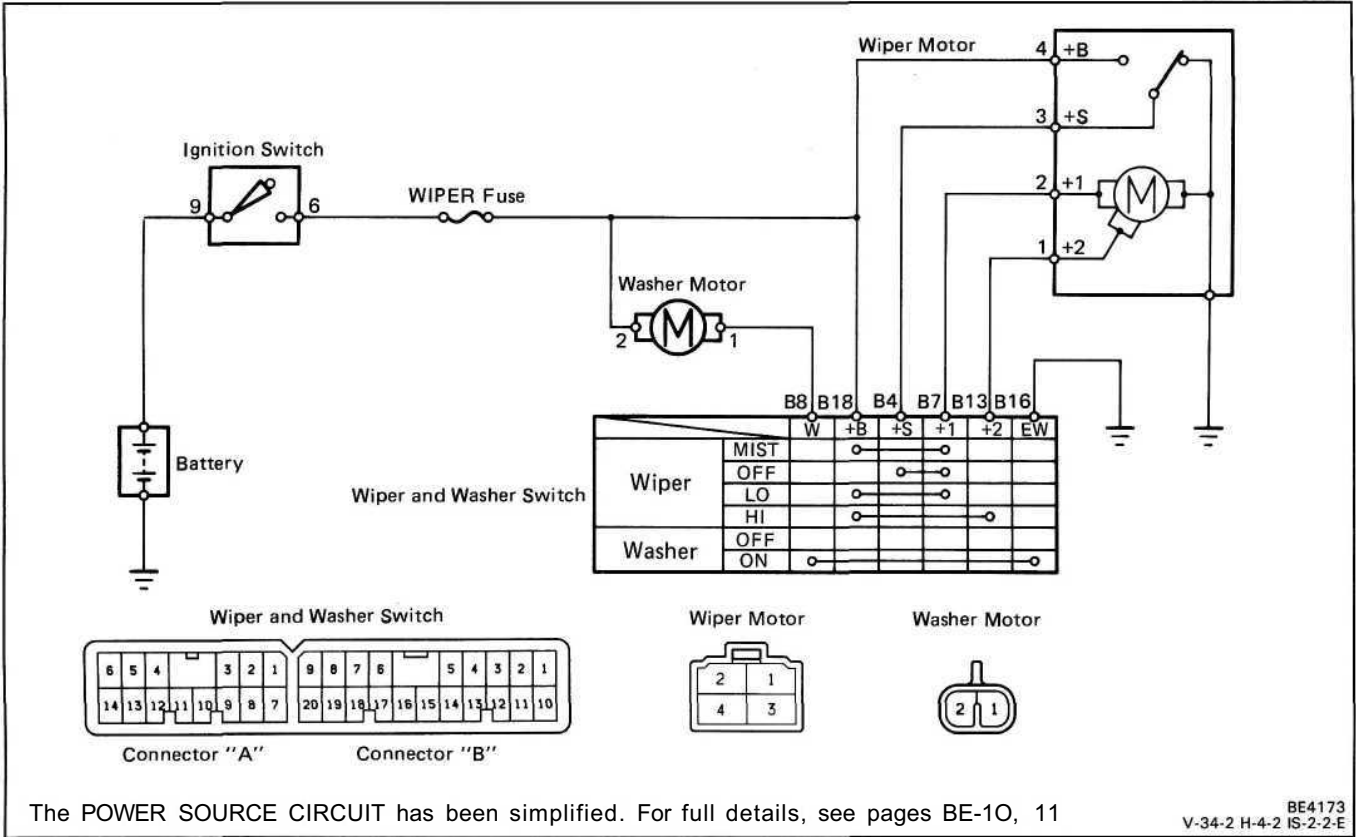

The POWER SOURCE CIRCUIT has been simplified. For full details, see pages BE-10, 11

(Front: Intermittent Type)

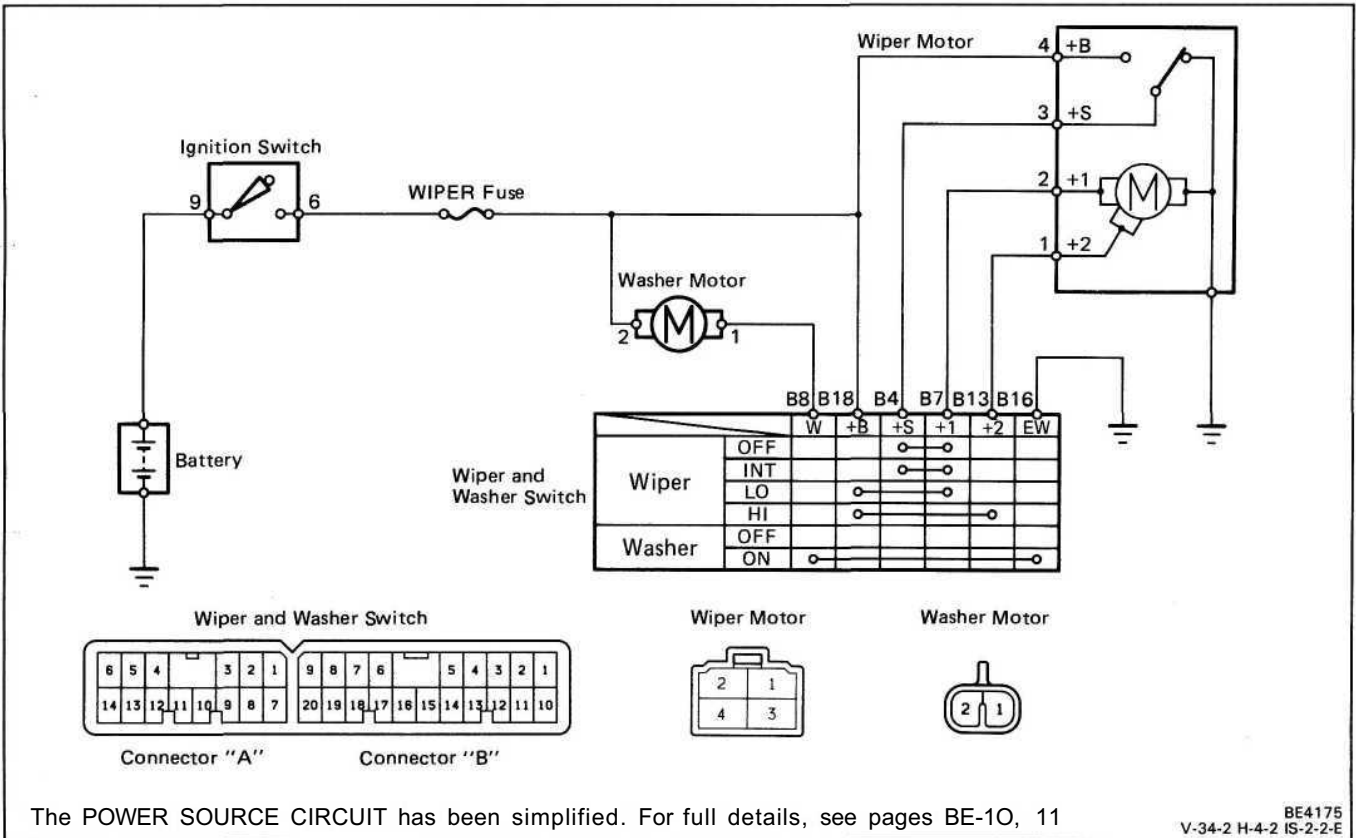

The POWER SOURCE CIRCUIT has been simplified. For full details, see pages BE-10, 11

(Rear: Lift-up type door)

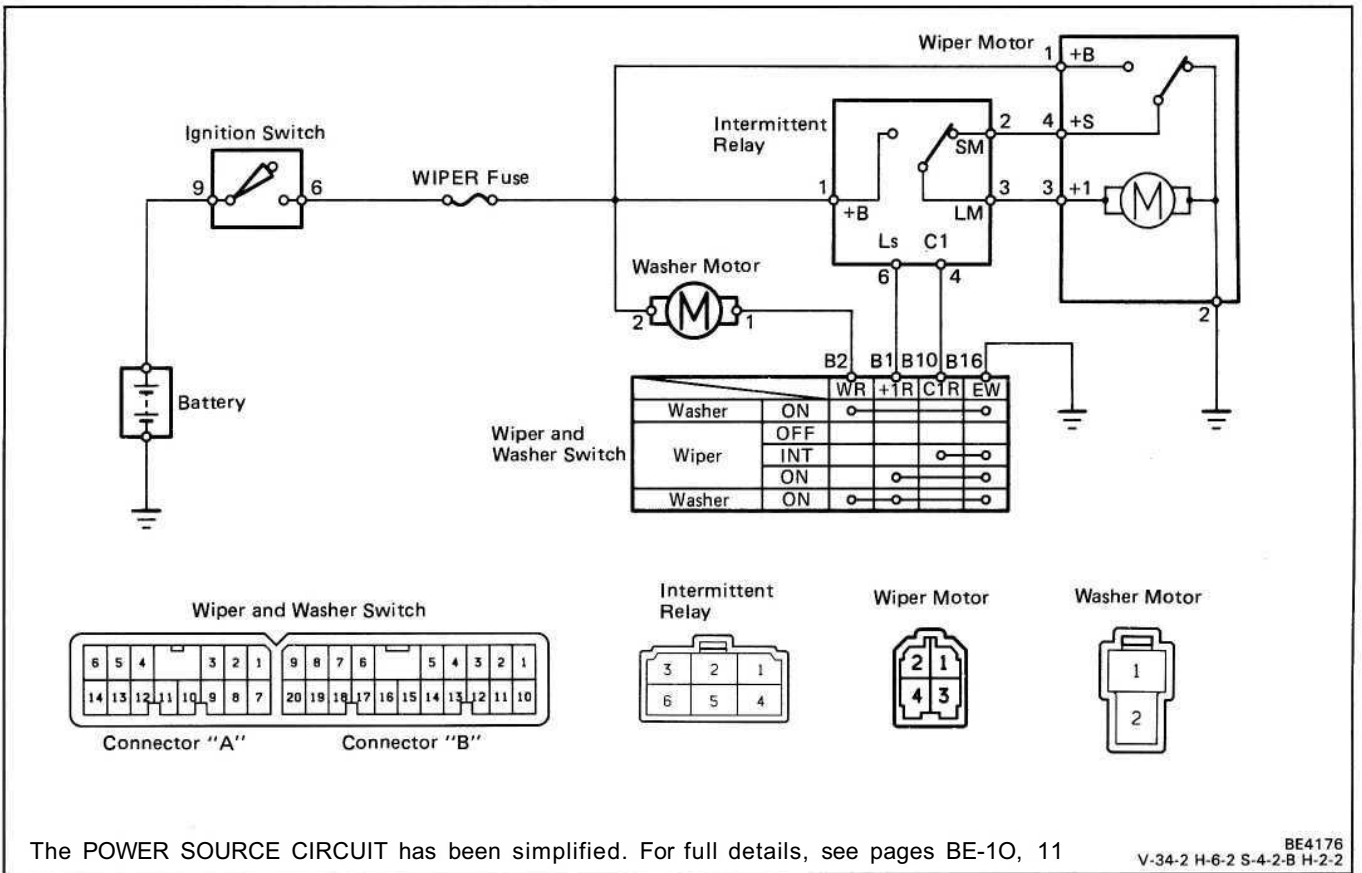

(Rear: Swing type door)

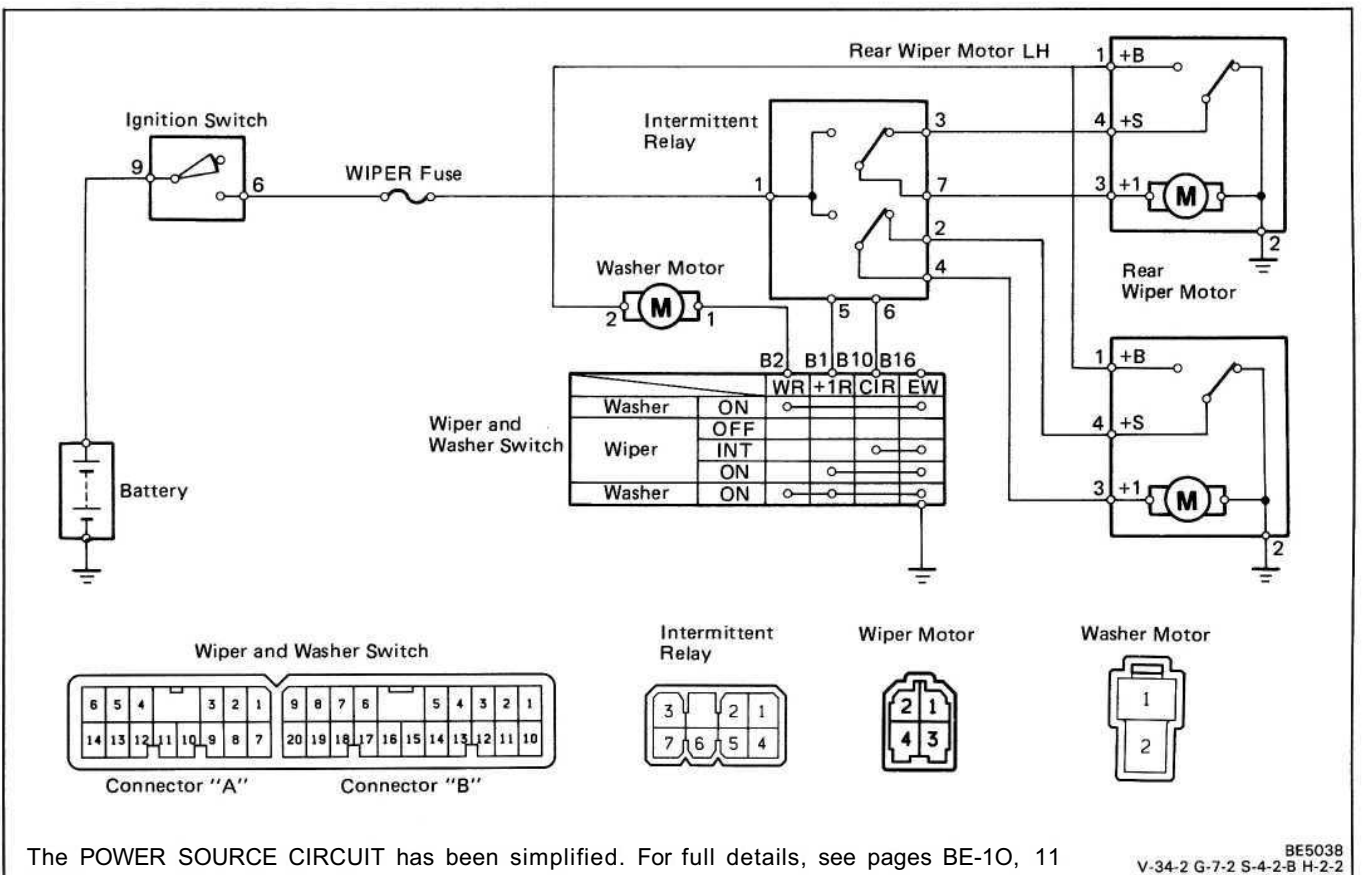

Troubleshooting

Problem	Possible cause	Remedy	Page	
			Front	Rear
Wiper do not operate or return to off position	WIPER fuse blown Wiper motor faulty Wiper switch faulty Wiring or ground faulty	Replace fuse and check for short Check motor Check switch Repair as necessary	BE-4, 6 BE-44 BE-41	BE-4, 6 BE-45,46 BE-41
Wiper do not operate in Mist position	Wiper switch faulty Wiper motor faulty Wiring or ground faulty	Check switch Check motor Repair as necessary	BE-41 BE-44	— — —
Wiper do not operate in Inter-mittent (INT) position	Wiper relay faulty Wiper switch faulty Wiper motor faulty Wiring or ground faulty	Check relay Check switch Check motor Repair as necessary	BE-42 BE-41 BE-44	BE-42,43 BE-41 BE-45,46
Washer do not operate	Washer hose or nozzle clogged Washer motor faulty Washer switch faulty Wiring or ground faulty	Repair as necessary Check motor Check switch Repair as necessary	BE-44 BE-41	BE-45,46 BE-41

Parts Replacement

See Parts Replacement of Combination Switch on page BE-25.

Reference: LHD Vehicles

Mist Wiper Switch

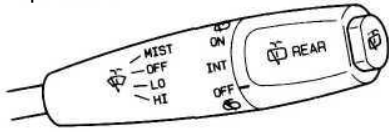

Intermittent Wiper Switch (w/o Interval Adjuster)

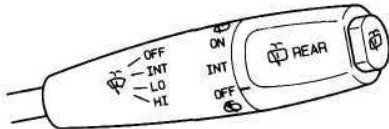

Connector "A"

Connector "B"

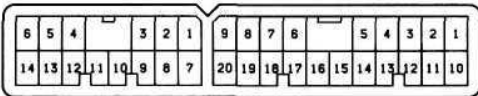

Reference: For RHD vehicles, the switches are always symmetrically opposite to those of LHD vehicles.

BE4177
BE4178
V-34-2

Parts Inspection

Wiper System

1. INSPECT SWITCHES

(Front Wiper and Washer Switch/Continuity)

(Mist Wiper)

Terminal (Color)		B4 (L-R)	B7 (L-B)	B8 (L)	B13 (L-0)	B16 (B)	B18 (L-W)
Switch position							
Wiper	OFF		○				○
	MIST	○	○				
	LO		○				○
	HI				○		○
Washer	OFF						
	ON			○		○	

(Intermittent Wiper)

Terminal (Color)		B4 (L-R)	B7 (L-B)	B8 (L)	B12 (Y-B)	13 (L-0)	B16 (B)	B18 (L-W)
Switch position								
Wiper	OFF	○	○					
	INT	○	○		○		○	
	LO		○					○
	HI					○		○
Washer	OFF							
	ON			○			○	

(Rear Wiper and Washer Switch/Continuity)

Terminal (Color)		B1 (G)	B2 (V)	B10 (0)	B16 (B)
Switch position					
Washer	ON		○		○
Wiper	OFF				
	INT			○	○
	ON	○			○
Washer	ON	○	○		○

If continuity is not as specified, replace the switch.

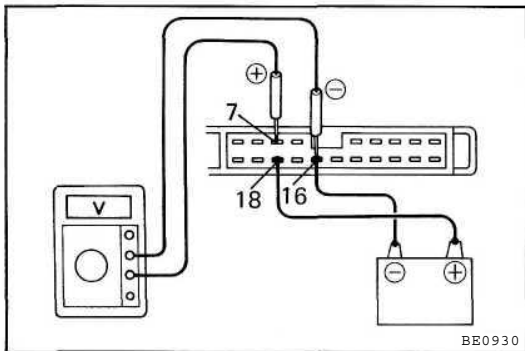
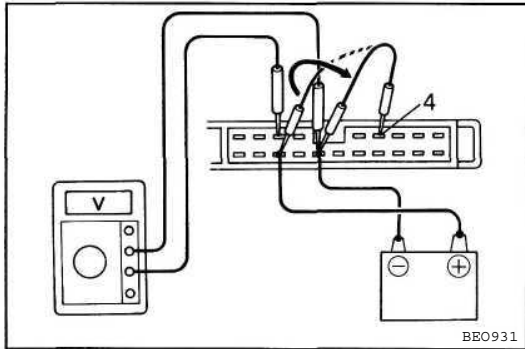
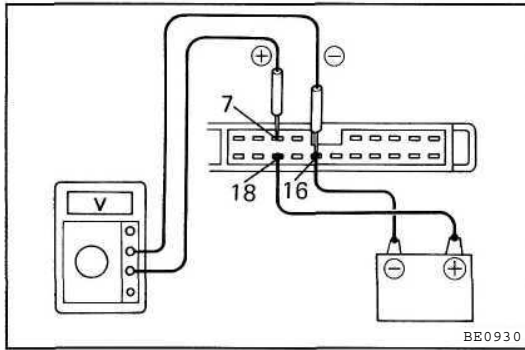

2. INSPECT FRONT WIPER RELAY
(Intermittent wiper: Front)

(Operation at Intermittent)

- (a) Turn the wiper switch to INT position.
- (b) Turn the intermittent time control switch to FAST position.
- (c) Connect the positive (+) lead from the battery to terminal B18 and the negative (-) lead to terminal B16.
- (d) Connect the positive (+) lead from the voltmeter to terminal B7 and the negative (-) lead to terminal B16, check that the meter needle indicates battery voltage.
- (e) After connecting terminal B4 to terminal B18, connect to terminal B16. Then, check that the voltage rises from 0 volt to battery voltage within the times as shown in the table.

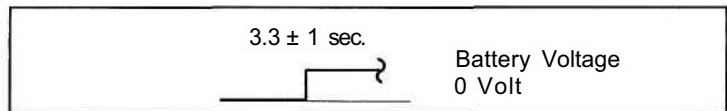

If operation is not as specified, replace the switch.

(Operation as Washer Linked)

- (a) Connect the positive (+) lead from the battery to terminal B18 and the negative (-) lead to terminal B16.
- (b) Connect the positive (+) lead from the voltmeter to terminal B7 and the negative (-) lead to terminal B16.
- (c) Push in the washer switch. Check that the voltage changes as shown in the table.

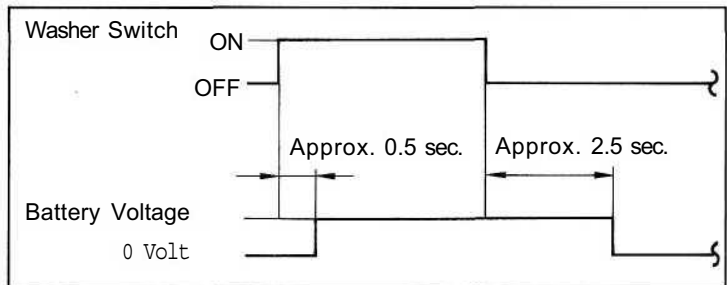

If operation is not as specified, replace the switch.

Relay Side

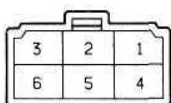

3. INSPECT REAR WIPER RELAY
(Continuity/Lift-up type door)

- (a) Check that there is no continuity between terminals 1 and 3.
- (b) Check that there is continuity between terminals 2 and 3.

If continuity is not as specified, replace the relay.

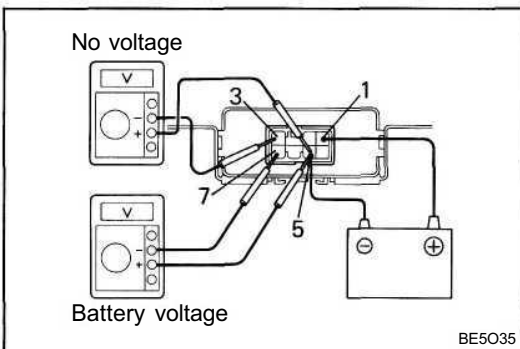
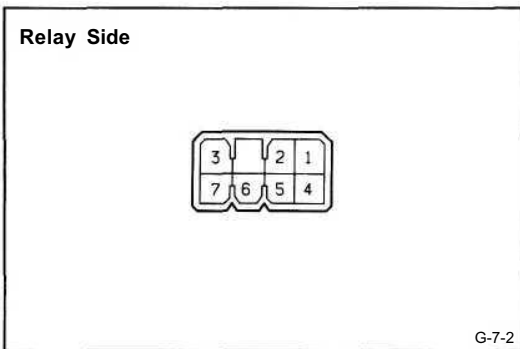
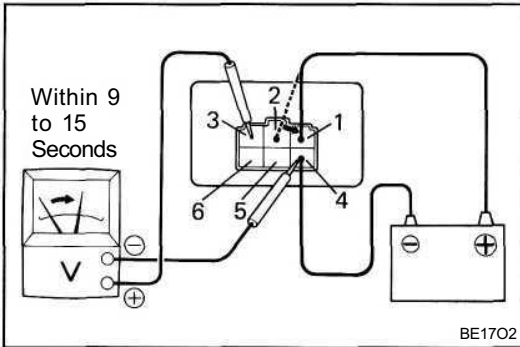
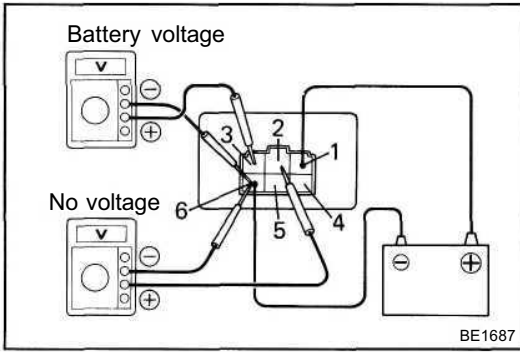

(Operation/Lift-up type door)

- (a) Connect the positive (+) lead from the battery to terminal 1 and the negative (—) lead to terminal 6.
- (b) Connect the positive (+) lead from the voltmeter to terminal 2 and the negative (—) lead to terminal 6, check that the meter needle indicates to 0 volts.
- (c) Connect the positive (+) lead from the voltmeter to terminal 3 and the negative (—) lead to terminal 6, check that the meter needle indicates to battery voltage.

If operation is not as specified, replace the relay.

(Intermittent Operation/Lift-up type door)

- (a) Connect the positive (+) lead from the battery to terminal 2 and the negative (—) lead to terminal 4.
- (b) Connect the positive (+) lead from the voltmeter to terminal 3 and the negative (—) lead to terminal 4.
- (c) After disconnecting the positive (+) lead from terminal 2, connect it to terminal 1, and then, check that the meter needle rises from 0 volts to battery voltage within 9 to 15 seconds.

If operation is not as specified, replace the relay.

(Continuity/Swing type door)

- (a) Check that there is no continuity between terminals 1 and 3 (for left side wiper motor).
- (b) Check that there is continuity between terminals 3 and 7 (for left side wiper motor).
- (c) Check that there is no continuity between terminals 1 and 4 (for right side wiper motor).
- (d) Check that there is continuity between terminals 4 and 2 (for right side wiper motor).

If continuity is not as specified, replace the relay.

(Operation/Swing type door)

(for left side wiper motor)

- (a) Connect the positive (+) lead from the battery to terminal 1 and the negative (—) lead to terminal 5.
- (b) Connect the positive (+) lead from the voltmeter to terminal 3 and the negative (—) lead to terminal 5, check that the meter needle indicates to 0 volts.
- (c) Connect the positive (+) lead from the voltmeter to terminal 7 and the negative (—) lead to terminal 5, check that the meter needle indicates to battery voltage.

If operation is not as specified, replace the relay.

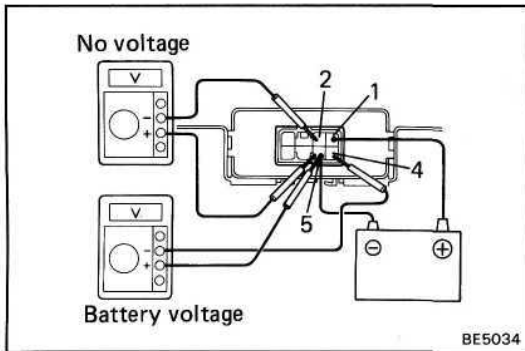

(for right side wiper motor)

- Connect the positive (+) lead from the battery to terminal 1 and the negative (—) lead to terminal 5.
- Connect the positive (+) lead from the voltmeter to terminal 2 and the negative (—) lead to terminal 5, check that the meter needle indicates to 0 volts.
- Connect the positive (+) lead from the voltmeter to terminal 4 and the negative (—) lead to terminal 5, check that the meter needle indicates to battery voltage.

If operation is not as specified, replace the relay.

(Intermittent Operation/Swing type door)

(for left side wiper motor)

- Connect the positive (+) lead from the battery to terminal 1 and the negative (—) lead to terminal 6.
- Connect the positive (+) lead from the voltmeter to terminal 7 and the negative (—) lead to terminal 6.
- After disconnecting the positive (+) lead from terminal 3, connect it to terminal 1, and then, check that the meter needle rises from 0 volts to battery voltage within 6 to 10 seconds.

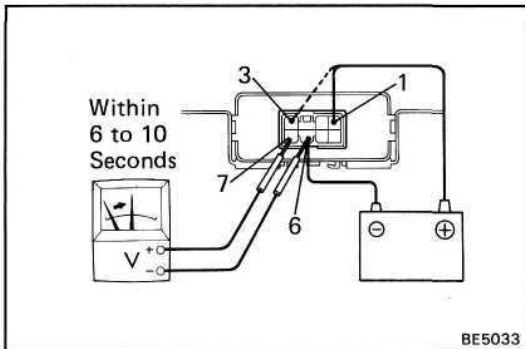

If operation is not as specified, replace the relay,

(for right side wiper motor)

- Connect the positive (+) lead from the battery to terminal 1 and the negative (—) lead to terminal 6.
- Connect the positive (+) lead from the voltmeter to terminal 4 and the negative (—) lead to terminal 6.
- After disconnecting the positive (+) lead from terminal 1, connect it to terminal 2, and then, check that the meter needle rises from 0 volts to battery voltage within 6 to 10 seconds.

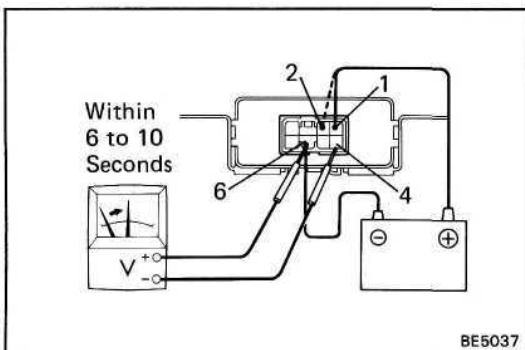

If operation is not as specified, replace the relay.

4. INSPECT FRONT WIPER MOTOR (Operation at Low Speed)

Connect the positive (+) lead from the battery to terminal 2 and the negative (—) lead to the motor body, check that the motor operates as low speed.

If operation is not as specified, replace the motor.

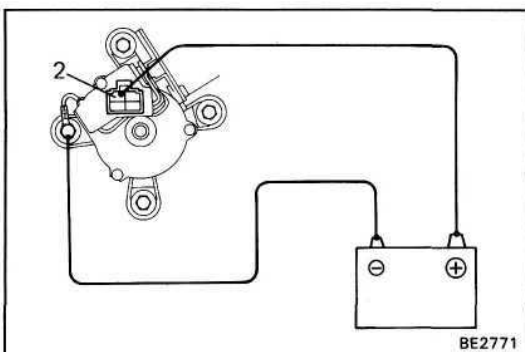

(Operation at High Speed)

Connect the positive (+) lead from the battery to terminal 1 and the negative (—) lead to the motor body, check that the motor operation at high speed.

If operation is not as specified, replace the motor.

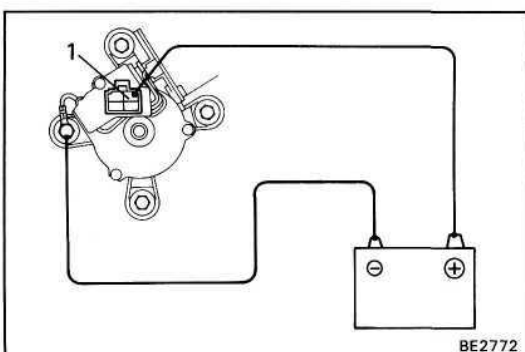

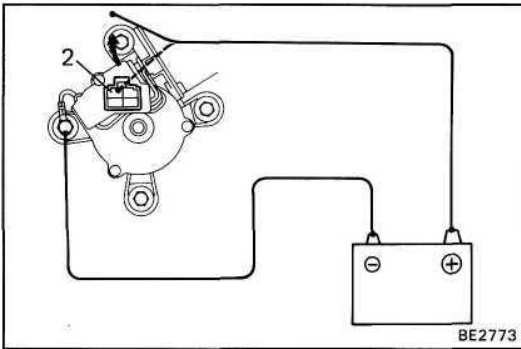

(Operation, Stopping at Stop Position)

- (a) Operate the motor at low speed and stop the motor operation anywhere except at the stop position by disconnecting positive (+) lead from terminal 2.

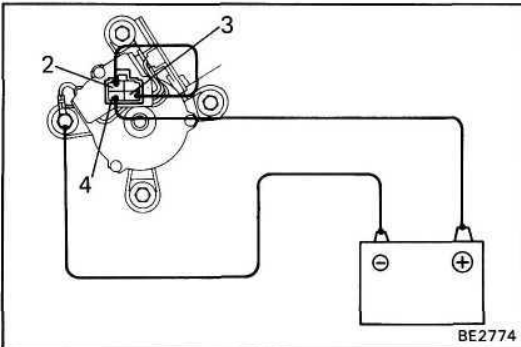

- (b) Connect terminals 2 and 3.

- (c) Connect the positive (+) lead from the battery to terminal 4 and the negative (-) lead to the motor body, check that the motor stops running at the stop position after the motor operates again.

If operation is not as specified, replace the motor.

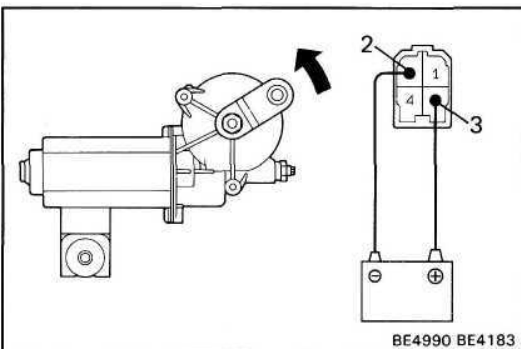

5. INSPECT REAR WIPER MOTOR

(Lift-up type door/Operation at Low Speed)

Connect the positive (+) lead from the battery to terminal 3 and the negative (-) lead to terminal 2, check that the motor operates at low speed.

If operation is not at specified, replace the motor.

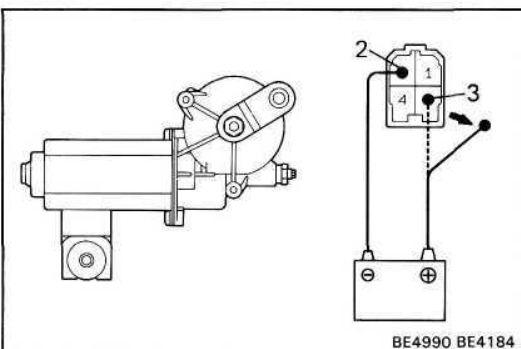

(Lift-up type door/Operation, Stopping at Stop Position)

- (a) Operate the motor at low speed and stop the motor operation anywhere except at the stop position by disconnecting positive (+) lead from terminal 3.

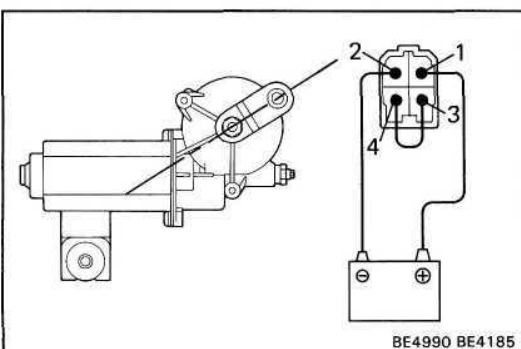

- (b) Connect terminals 3 and 4.

- (c) Connect the positive (+) lead from the battery to terminal 1 and the negative (-) lead to terminal 2, check that the motor stops running at the stop position after the motor operates again.

If operation is not as specified, replace the motor.

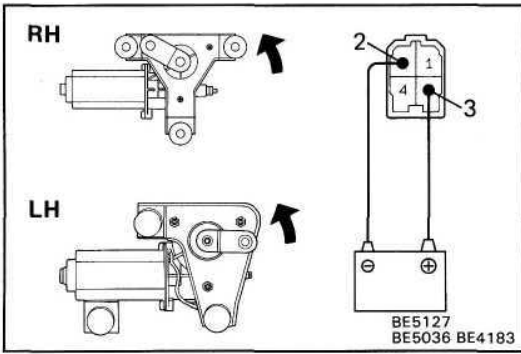

(Swing type door/Operation at Low Speed)

Connect the positive (+) lead from the battery to terminal 3 and the negative (—) lead to terminal 2, check that the motor operates as low speed.

If operation is not as specified, replace the motor.

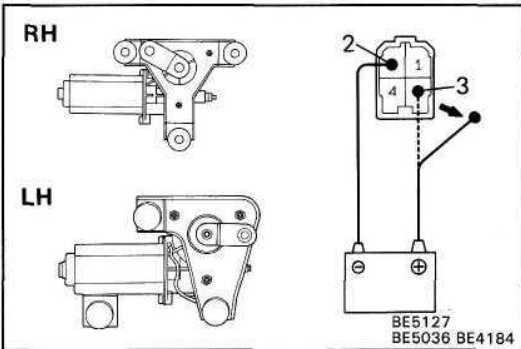

(Swing type door/Operation, Stopping at Stop Position)

(a) Operate the motor at low speed and stop the motor operation anywhere except at the stop position by disconnecting positive (+) lead from terminal 3.

(b) Connect terminals 3 and 4.

(c) Connect the positive (+) lead from the battery to terminal 1 and the negative (—) lead to terminal 2, check that the motor stops running at the stop position after the motor operates again.

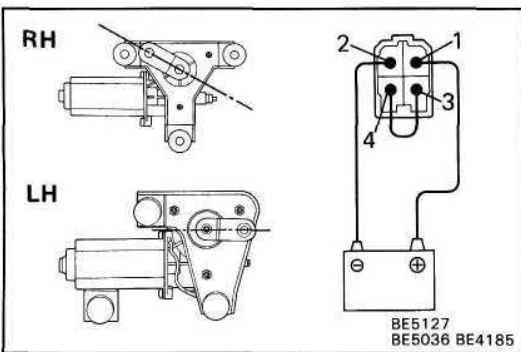

If operation is not as specified, replace the motor.

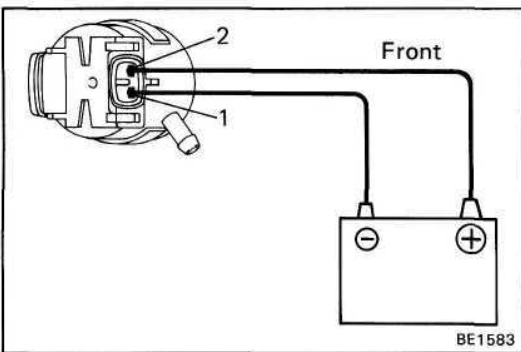

Washer System

1. INSPECT WASHER SWITCH (Washer Switch)

See Wiper and Washer Switch on page BE-41.

2. INSPECT WASHER MOTOR

Connect the positive (+) lead from the battery to terminal 2 and the negative (—) lead to terminal 1, check that the motor operates.

NOTICE: These tests must be performed quickly (within 20 seconds) to prevent the coil from burning out.

If operation is not as specified, replace the motor.

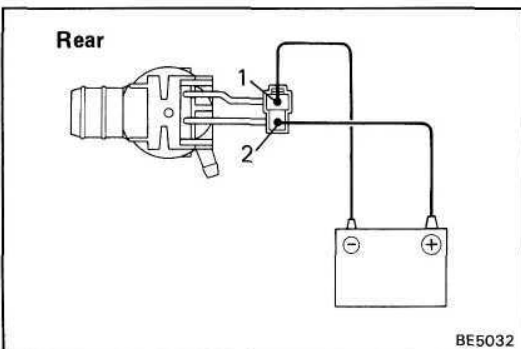

COMBINATION METER

Parts Location

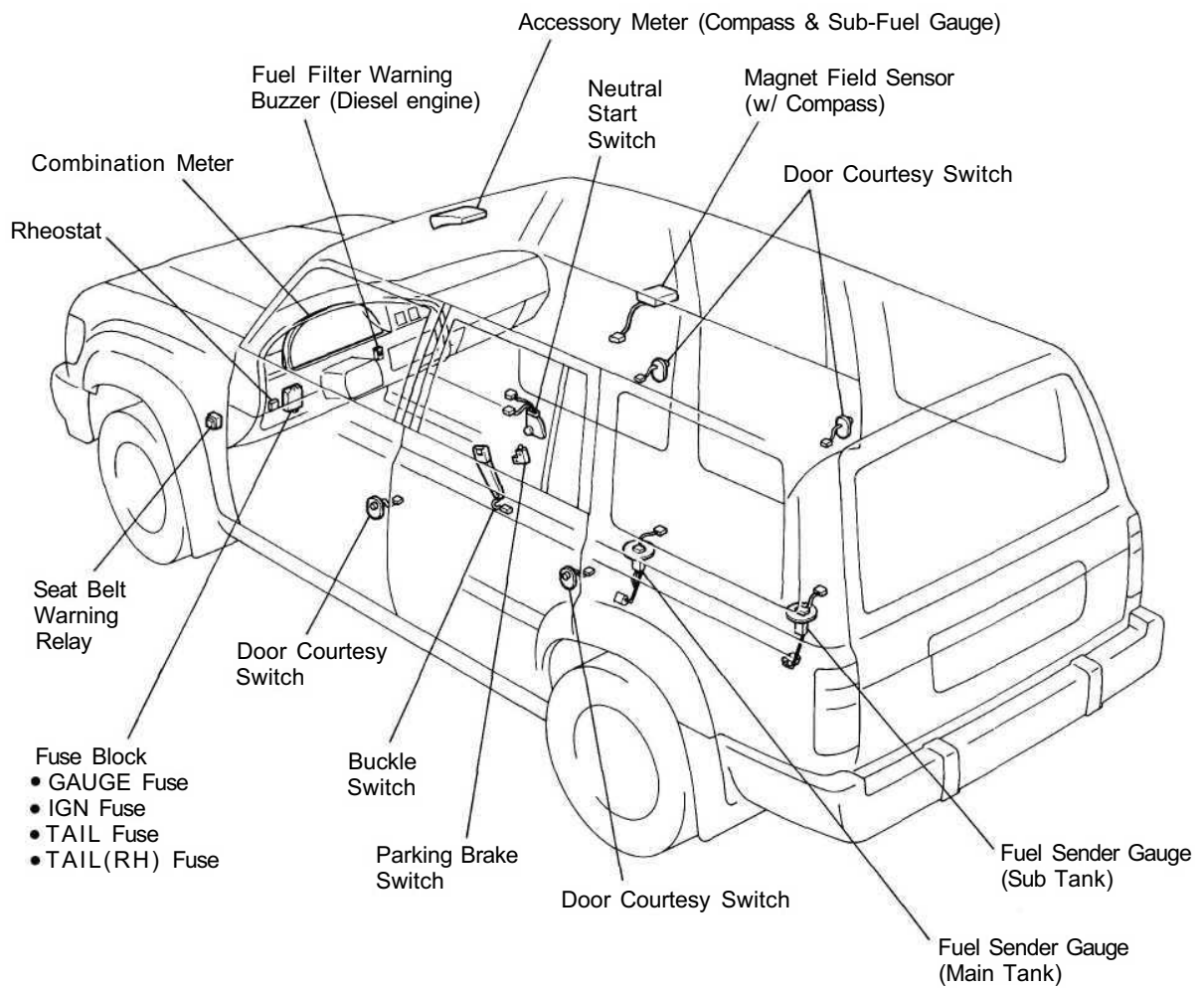

Parts Location (Cont'd)

3F-E, 3F Engine

- Low Oil Pressure Warning Switch
- Oil Pressure Sender Gauge

Air Filter Warning Switch

Brake Fluid Level Warning Switch

- Relay Block No. 2
- DOME Fuse

Water Temperature Sender Gauge

1HD-T, 1HZ Engine

Water Temperature Sender Gauge

- Low Oil Pressure Warning Switch
- Oil Pressure Sender Gauge

Brake Fluid Level Warning Switch

Turbo Indicator Pressure Switch (1HD-T engine)

Vacuum Switch (Brake Warning)

- Relay Block No. 2
- DOME Fuse

Air Cleaner Warning Switch

Fuel Filter Warning Switch

Tacho Pick Sensor (w/ Tachometer)

Meter Circuit

(w/o Tachometer: Except G.C.C.)

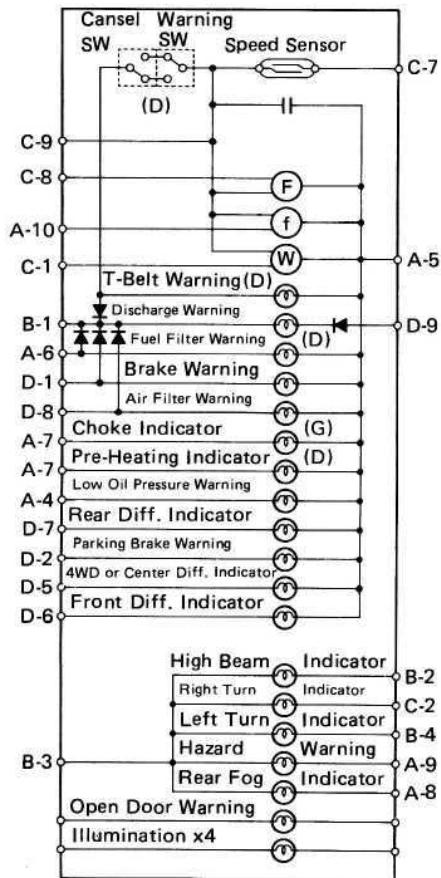
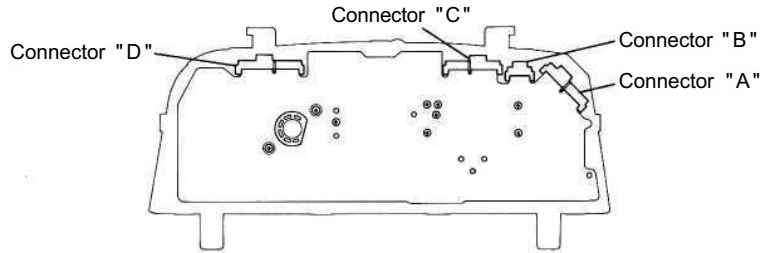
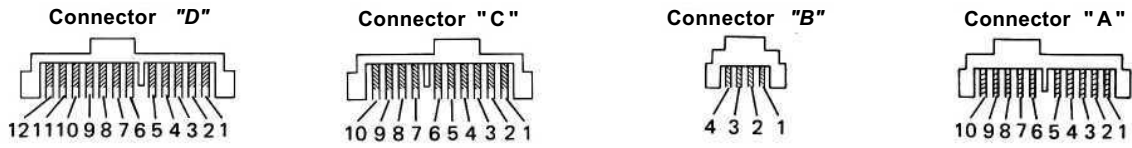

- (F) : Fuel Gauge
- (f) : Fuel Gauge (for Sub-Tank)
- (W) : Water Temperature Gauge
- (D) : Diesel engine
- (G) : Gasoline engine

BE1266 BE1270 BE5017 BE2576
BE5117

No.	Wiring connector side
A	4 Low oil pressure warning switch
	5 GAUGE fuse
	6 Fuel filter warning switch and buzzer (Diesel engine)
	7 Choke switch (Gasoline engine) or glow timer relay (Diesel engine)
	8 Rear fog light switch (Europe)
B	9 Hazard warning light switch (Europe)
	10 Fuel sender gauge (Sub-Tank)
	1 CHARGE fuse (w/o IC ALT) or charge light relay (w/ IC ALT)
	2 Headlight Lo-beam
C	3 Ground
	4 Turn signal light switch (Left)
	1 Water temperature sender gauge
	2 Turn signal light switch (Right)
D	3 TAIL fuse or TAIL (RH) fuse
	7 Speed control unit
	8 Fuel sender gauge (Main-Tank)
	9 Ground
	10 Ground of rheostat
	1 Brake fluid level warning switch (Europe) and vacuum warning switch (Diesel)
	2 Parking brake switch (Europe)
	5 4WD indicator switch
	6 Front diff. lock indicator switch
	7 Rear diff. lock indicator switch
	8 Air Filter warning switch
	9 IGN fuse
11 DOME fuse	
12 Door courtesy switch	

(w/ Tachometer)

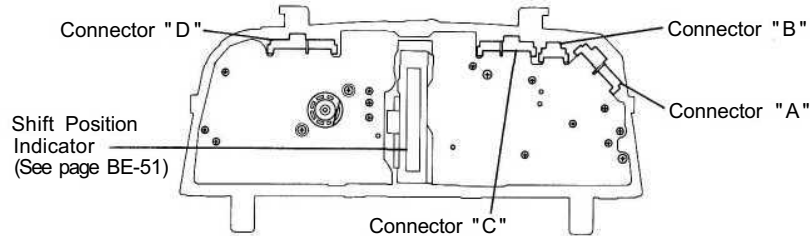
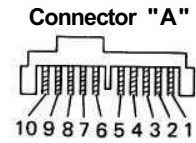
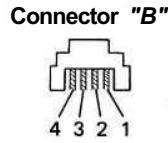
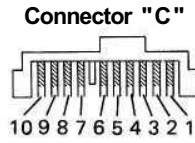
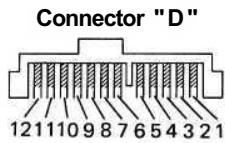

BE1266 BE1270 BE5017 BE2576
BE5005

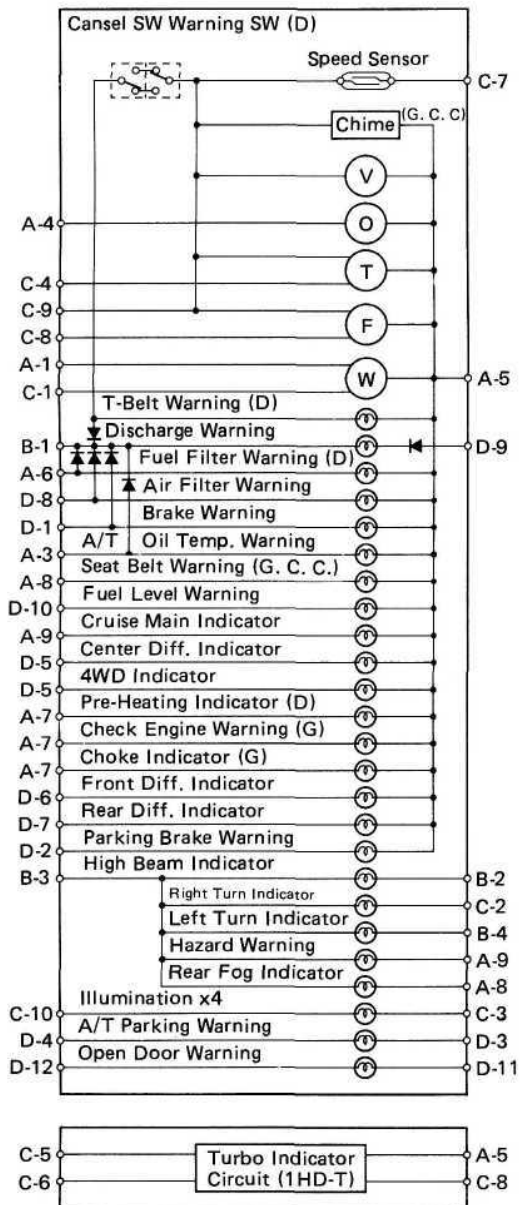

- Ⓥ : Voltmeter
- Ⓞ : Oil Pressure Gauge
- Ⓣ : Tachometer
- Ⓜ : Water Temperature Gauge
- (D) : Diesel engine
- (G) : Gasoline engine

No.	Wiring connector side
A	1 Ground
	3 A/T fluid temperature sensor (A/T)
	4 Oil pressure sender gauge
	5 GAUGE fuse
	6 Fuel filter warning switch and buzzer (Diesel engine)
	7 Glow timer relay (Diesel engine) EFI ECU (3F-E engine) Choke switch (3F engine)
	8 Rear fog light switch (Europe) or seat belt warning relay (G.C.C.)
	9 Hazard warning light switch (Europe) or cruise control ECU (w/ Cruise Control System)
	B
2 Headlight Hi-Beam	
3 Ground	
4 Turn signal light switch (Left)	
C	1 Water temperature sender gauge
	2 Turn signal light switch (Right)
	3 TAIL or TAIL (RH) fuse
	4 Tacho pick sensor (Diesel engine) or Igniter (Gasoline engine)
	5 High pressure switch (1HD-T engine)
	6 Low pressure switch (1HD-T engine)
	7 Speed control unit
	8 Fuel sender gauge
	9 Ground
	10 Rheostat or ground
D	1 Brake fluid level warning SW (Europe) and vacuum warning switch (Diesel) or brake fluid level warning SW and parking brake SW (Except. Europe) and vacuum warning switch (Diesel)
	2 Parking brake SW (Europe)
	3 Neutral start switch (A/T)
	4 Neutral position switch (A/T)
	5 4WD indicator switch
	6 Front diff. lock indicator switch
	7 Rear diff. lock indicator switch
	8 Air filter warning switch
	9 IGN fuse
	10 Fuel sender gauge
	11 DOME fuse
	12 Door courtesy switch

(w/o Tachometer: G.C.C.)

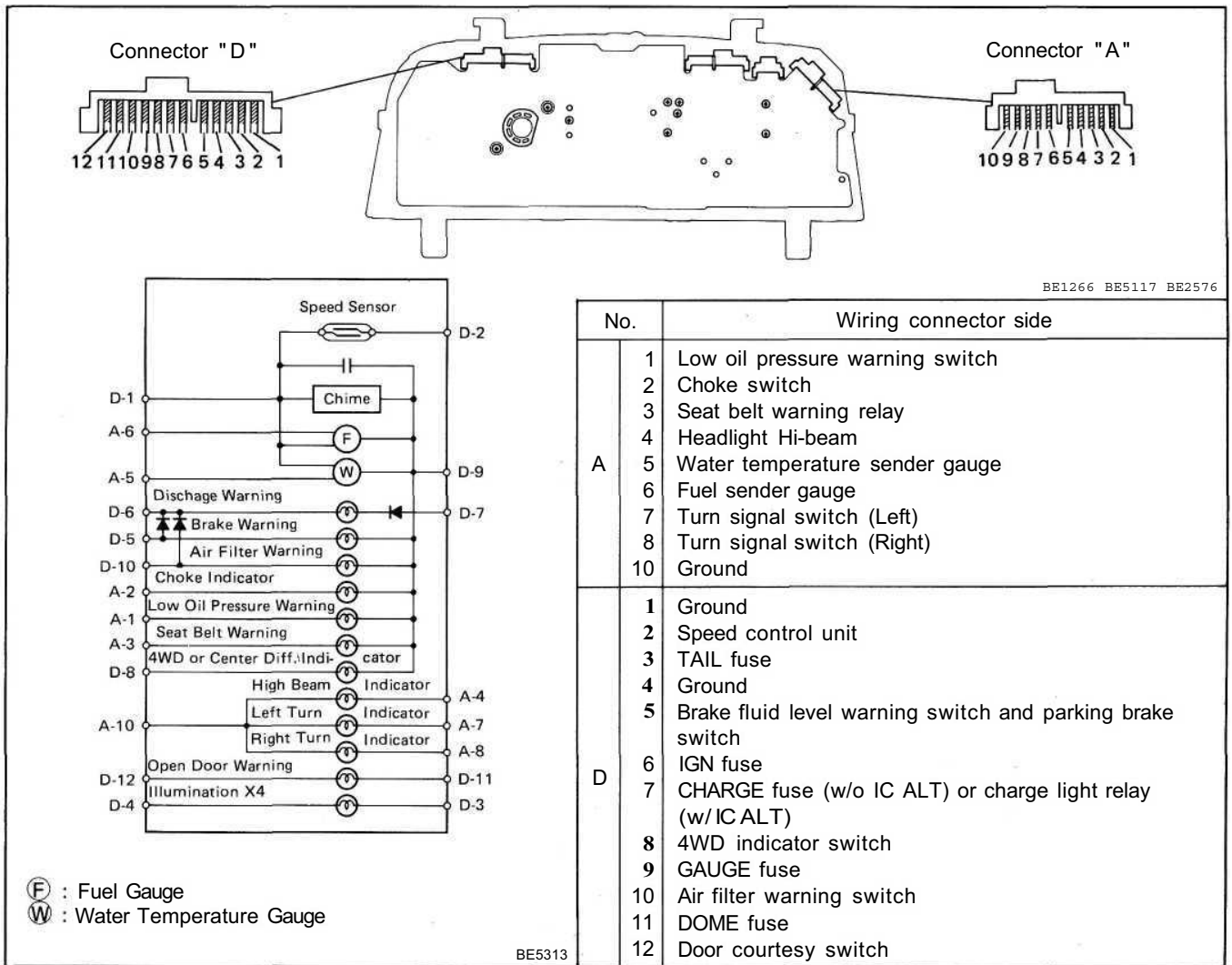

(Shift Position Indicator)

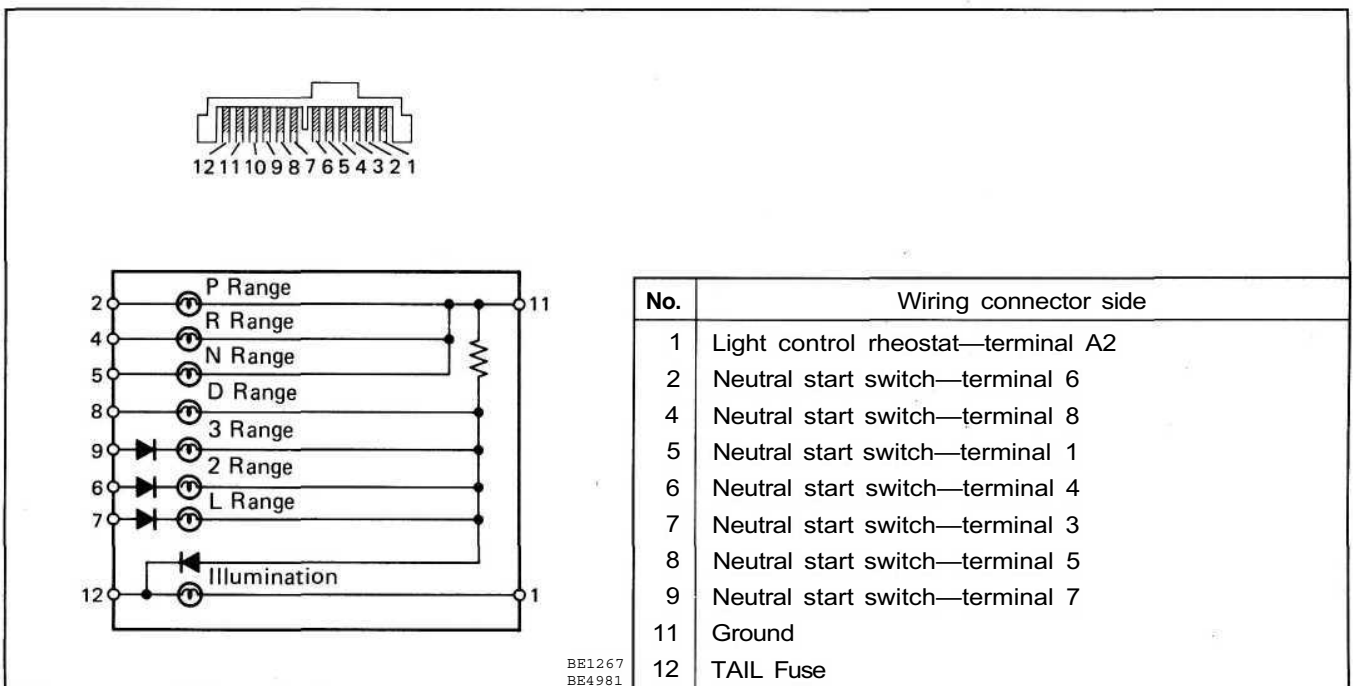

(Accessory Meter/Over Head Console)

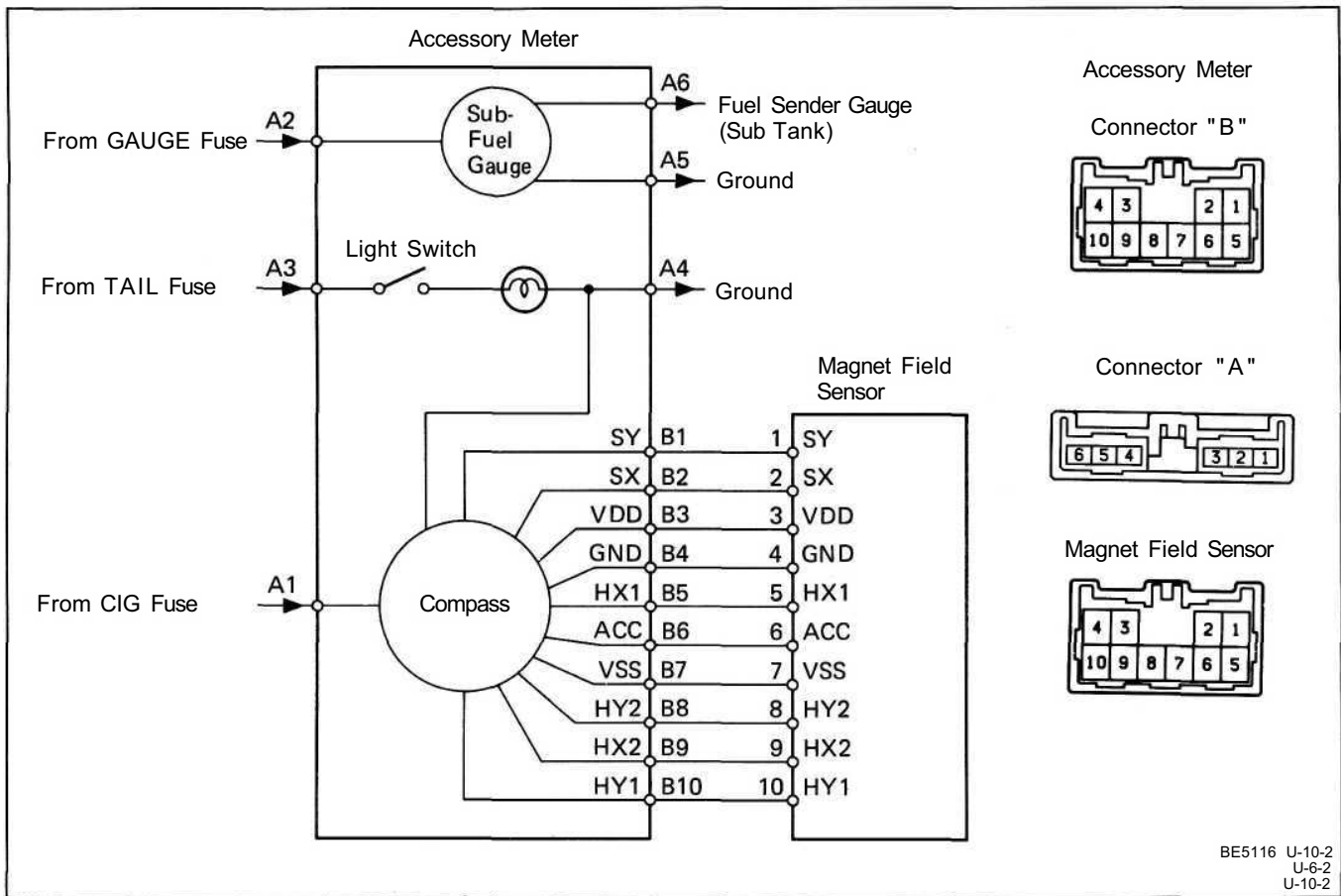

BE5116 U-10-2
U-6-2
U-10-2

Troubleshooting

Problem	Possible cause	Remedy	Page
Combination meter does not operate	GAUGE fuse blown Wiring or ground faulty	Replace fuse and check for short Repair as necessary	BE-4,6
Speedometer does not operate	Speedometer cable faulty Speedometer faulty	Check cable Check speedometer	BE-55
Speed warning chime does not sound	Speed warning chime faulty Speed warning switch faulty Wiring or ground faulty	Check speed warning chime Check speed warning switch Repair as necessary	BE-56 BE-55
Tachometer does not operate	Tachometer faulty Pick-up sensor faulty Wiring or ground faulty	Check tachometer Check pick-up sensor Repair as necessary	BE-56 BE-56
Fuel gauge does not operate (Main)	Receiver gauge faulty Sender gauge faulty Wiring or ground faulty	Check gauge Check gauge Repair as necessary	BE-57 BE-57
Fuel level warning light does not light up	Bulb burned out Warning switch faulty Wiring or ground faulty	Replace or check bulb Check switch Repair as necessary	BE-5 BE-59
Fuel filter warning light does not light, warning buzzer does not sound	Bulb burned out Warning switch faulty Warning buzzer faulty Wiring or ground faulty	Replace or check bulb Check switch Check buzzer Repair as necessary	BE-5 BE-60 BE-60
Water temperature gauge does not operate	Receiver gauge faulty Sender gauge faulty Wiring or ground faulty	Check gauge Check gauge Repair as necessary	BE-60 BE-60
Low oil pressure warning light does not light up	Bulb burned out Warning switch faulty Wiring or ground faulty	Replace or check bulb Check switch Repair as necessary	BE-5 BE-61
Park warning light does not light up	Bulb burned out Parking brake switch faulty Wiring or ground faulty	Replace or check bulb Check switch Repair as necessary	BE-5 BE-63

Troubleshooting (Cont'd)

Problem	Possible cause	Remedy	Page
Breake warning light does not light up	Bulb burned out Level Warning switch faulty Vacuum switch faulty Parking brake switch faulty Wiring or ground faulty	Replace or check bulb Check switch Check switch Check switch Repair as necessary	BE-5 BE-64 BE-64 BE-63
Seat belt warning light does not light up	Bulb burned out Warning switch faulty Warning relay faulty Wiring or ground faulty	Replace or check bulb Check switch Check relay Repair as necessary	BE-5 BE-65 BE-66
Open door warning light does not light up	Bulb burned out Courtesy switch faulty Wiring or ground faulty	Replace or check bulb Check switch Repair as necessary	BE-5 BE-64
Timing belt warning light does not light up	Bulb burned out Warning switch faulty Wiring or ground faulty	Replace or check bulb Check switch Repair as necessary	BE-5 BE-66
Fuel gauge does not operate (Sub)	Receiver gauge faulty Sender gauge faulty Wiring or ground faulty	Check gauge Check gauge Repair as necessary	BE-58 BE-59
Voltmeter does not operate	Battery faulty Receiver gauge faulty Wiring or ground faulty	Check battery Check gauge Repair as necessary	BE-62
Oil pressure gauge does not operate	Receiver gauge faulty Sender gauge faulty Wiring or ground faulty	Check gauge Check gauge Repair as necessary	BE-62 BE-62
Meter illumination control system does not operate	Bulb burned out Rheostat faulty Wiring or ground faulty	Replace or check bulb Check rheostat Repair as necessary	BE-5 BE-67
Shift position indicator light does not light up (A/T)	Bulb burned out Switch faulty Wiring or ground faulty	Replace or check bulb Check switch Repair as necessary	BE-5 AT-28
Airfilter warning light does not light	Bulb burned out Warning switch faulty Wiring or ground faulty	Replace or check bulb Check switch Repair as necessary	BE-5 BE-67
Turbo indicator does not operate	Drive circuit faulty Pressure switch faulty Wiring or ground faulty	Check drive circuit Check switch Repair as necessary	BE-68 BE-67
Compass does not operate	Accessory meter faulty Magnet field sensor faulty Wiring or ground faulty	Check meter Check sensor Repair as necessary	BE-69 BE-70

Parts Adjustment

(Diesel Engine)

Adjustment of Interval Switch for Timing Belt Warning System

NOTICE: Work carefully so that components are not damaged in any way.

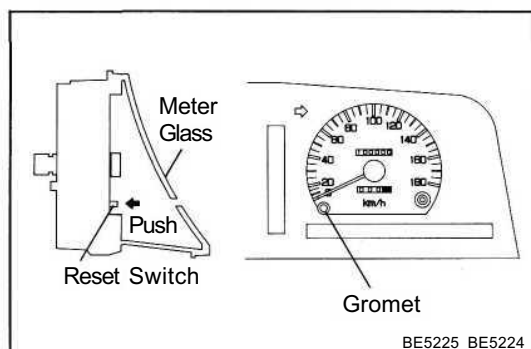

RESET CANCEL SWITCH

- (a) Remove the gromet from the meter glass.
- (b) Push the reset switch.

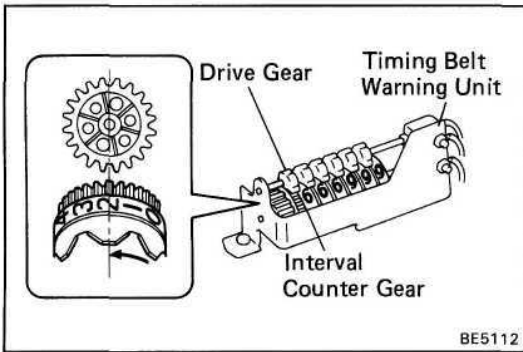

IF REPLACING TIMING BELT BEFORE WARNING LIGHT LIGHT UP

- (a) Remove the timing belt warning unit from the speedometer.
- (b) When installing the timing belt warning unit to the speedometer, rotate the interval counter gear in the direction of the arrow so that the tooth at number "2" on the interval counter gear engages with the drive gear on the speedometer side.

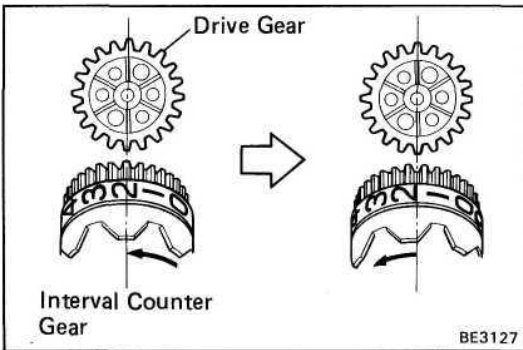

HINT: If the tooth at number "2" on the interval counter gear does not engage with the drive gear, move the tooth at number "2" slightly in the direction of the arrow until the tooth engage.

- (c) Install the timing belt warning unit to the speedometer.

HINT: If turn on the timing belt warning light, reset the cancel switch.

Old odometer reading value (b)	(c) Adjustment number for interval counter gear	
	km display	MPH display
10000	1	7
20000	0	6
30000	9	5
40000	8	4
50000	7	3
60000	6	2
70000	5	1
80000	4	0
90000	3	A
100000	2	B
110000	1	9
120000	0	8
130000	9	7
140000	8	6
150000	7	5
•	•	•
•	•	•
•	•	•

IF REPLACING SPEEDOMETER

- (a) Remove the timing belt warning unit from the speedometer.
- (b) Read the value in tens of thousands from the old odometer (taken to the next highest figure when the thousands column shows on thousand or more).
- (c) Find the value from (b) in the table on the left, then find the corresponding number from adjustment of the interval counter gear.

Example: When the old odometer shows.

013251 km
 |
 (b) = 020000
 |
 (c) = "0" for the interval counter gear number.

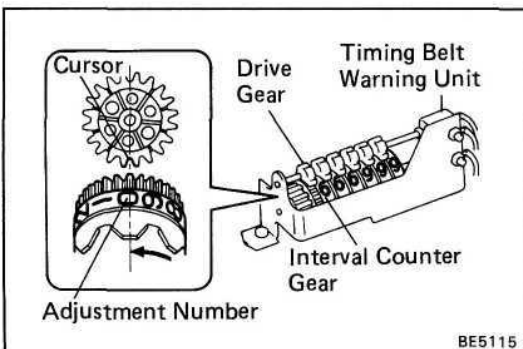

- (d) When installing the timing belt warning unit to the speedometer, rotate the interval counter gear in the direction of the arrow so that the number (c) on the interval counter gear aligns with the cursor on the drive gear on the speedometer side.

HINT: Check that the tooth beside to number on the counter gear engages the gap on the cursor port on the drive gear.

- (e) Install the timing belt warning unit to the speedometer.

Parts Inspection

Speedometer System

(mph)

Standard indication	Allowable range
20	21 – 23.5
40	41.5 – 44
60	62.5 – 66
80	83 – 87
100	104 – 108.5

(km/h)

Standard indication	Allowable range	
	Australia	Ex. Australia
20	17.5 – 21.5	21 – 25
40	38 – 42	41.5 – 46
60	58 – 63	62.5 – 67
80	78 – 84	83 – 88
100	99 – 104.5	104 – 109
120	119.5 – 125.5	125 – 130.5
140	139.5 – 146.5	145.5 – 151.5
160	159.5 – 167.5	166 – 173

1. INSPECT SPEEDOMETER (ON-VEHICLE)

- (a) Using a speedometer tester, inspect the speedometer for allowable indication error and check the operation of the odometer.

HINT: Tire wear and tire over or under inflation will increase the indication error.

- (b) Check the speedometer for pointer vibration and abnormal noise.

HINT: Pointer vibration can be caused by a loose speedometer cable.

2. INSPECT SPEED SENSOR

Check that there is continuity between terminals A and B four times per each revolution of the speedometer shaft.

If operation is not as specified, replace the speedometer.

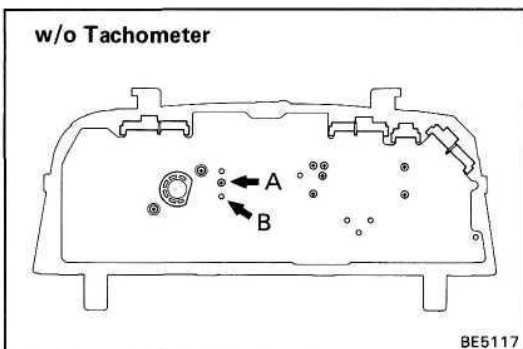
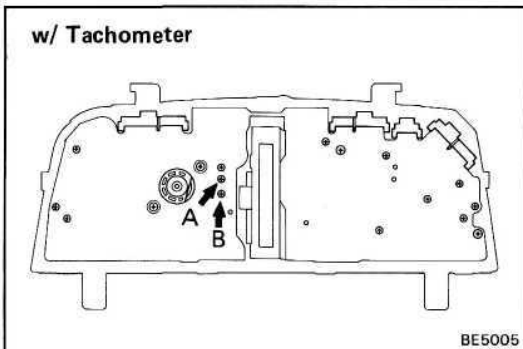

3. INSPECT SPEED WARNING CHIME SWITCH

- (a) Press down on the tabs and remove the combination meter glass from the combination meter case.

NOTICE: Be careful not to dirty or damage the speedometer panel.

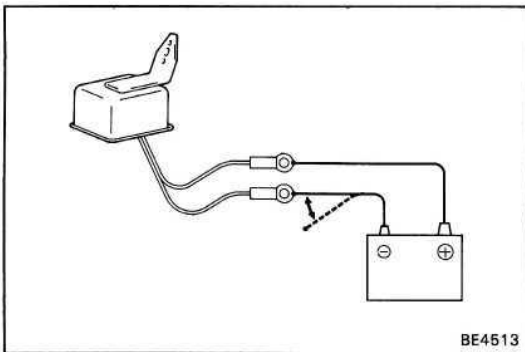
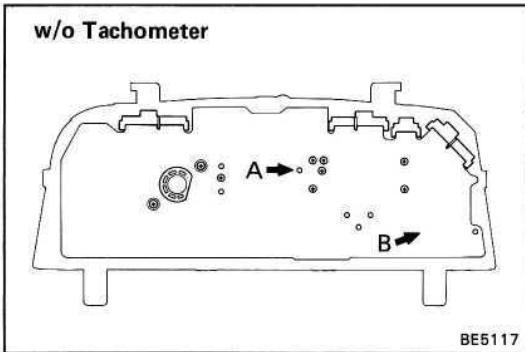
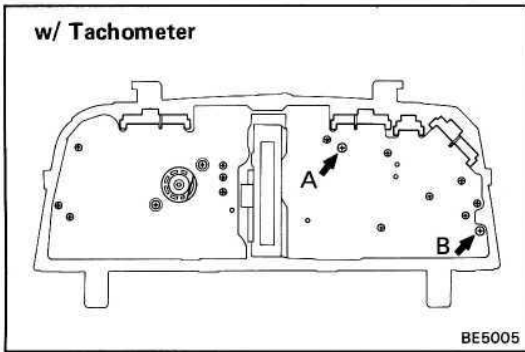

- (b) Move the speedometer needle to the 124 km/h or 77 mph mark and fix it there.
- (c) Keep on turning the speedometer shaft, check that the continuity between terminals A and B repeatedly fluctuates.

If operation is not as specified, replace the speedometer.

4. INSPECT SPEED WARNING CHIME

Apply battery voltage intermittently between terminals of the chime, check that the chime sounds.

HINT: The sound will be distorted if the chime is tilted. If operation is not as specified, replace the chime.

DC 13.5 V 20°C (68°F)		rpm
Standard indication	Allowable range	
700	610 – 750	
1,000	900 – 1,100	
2,000	1,875 – 2,125	
3,000	2,850 – 3,150	
4,000	3,850 – 4,150	
5,000	4,850 – 5,150	

Tachometer System

1. INSPECT TACHOMETER (ON-VEHICLE)

- (a) Connect a tune-up test tachometer, and start the engine.

NOTICE:

- Reversing the connection of the tachometer will damage the transistors and diodes inside.
- When removing or installing the tachometer, be careful not to drop or subject it to heavy shocks.

- (b) Compare the tester and tachometer indications. If error is excessive, replace the tachometer.

2. (Diesel Engine) INSPECT PICK-UP SENSOR

Measure the resistance between terminals 1 and 2.

Resistance: approx. 730 Ω

If resistance value is not as specified, replace the sensor.

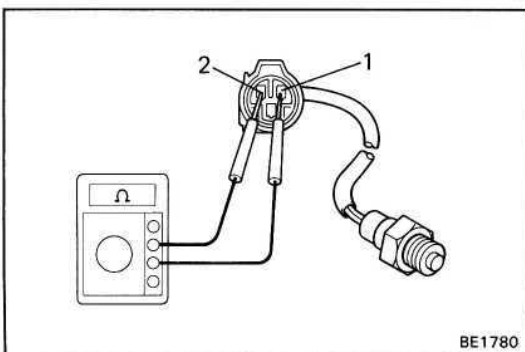

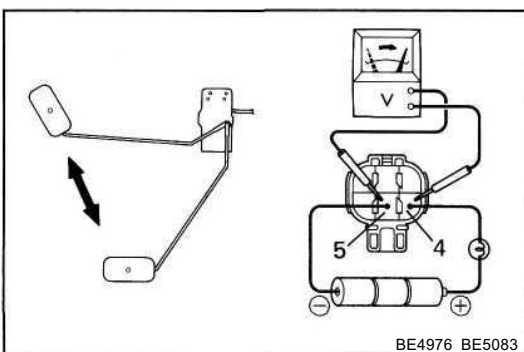
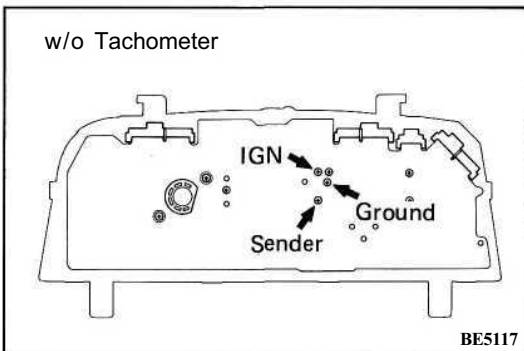
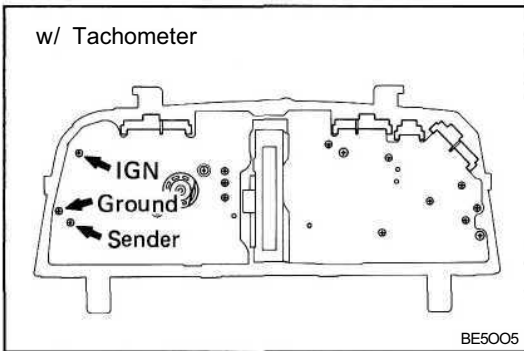
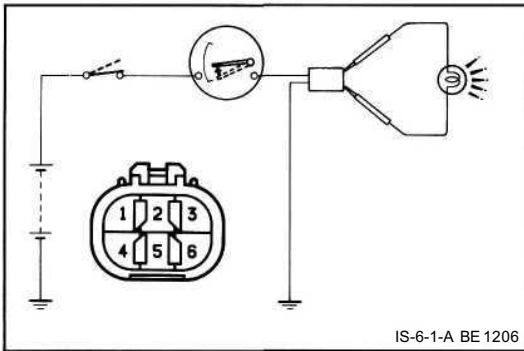
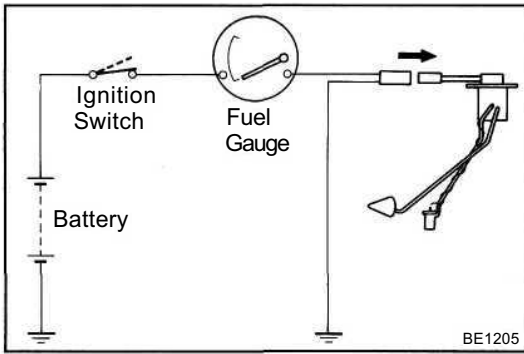

Fuel Gauge System (Main)

1. INSPECT RECEIVER GAUGE (Operation)

- (a) Disconnect the connector from the sender gauge.
- (b) Turn the ignition switch ON, check that the receiver gauge needle indicates EMPTY.
- (c) Connect terminals 4 and 5 on the wire harness side connector through a 3.4 watts test bulb.
- (d) Turn the ignition switch ON, check that the bulb lights up and the receiver gauge needle moves towards the full side.

HINT: Because of the silicon oil in the gauge, it will take a short time for needle to stabilize.

If operation is not as specified, inspect the receiver gauge resistance.

(Resistance)

Measure the resistance between terminals,

(w/ Tachometer)

Between terminals	Resistance (Ω)
IGN - Sender	85.5 - 105.5
IGN — Ground	126 - 150
Sender — Ground	*90 - 110

*: Include voltmeter resistance.

(w/o Tachometer)

Between terminals	Resistance (Ω)
IGN — Sender	49 - 61
IGN - Ground	99 - 121
Sender — Ground	148 - 182

If resistance value is not as specified, replace the receiver gauge.

2. INSPECT SENDER GAUGE (Operation)

(Operation)

- (a) Connect a series of three 1.5 volts dry cell batteries.
- (b) Connect the positive (+) lead from the dry cell batteries to terminal 4 through a 3.4 watts test bulb and the negative (—) lead to terminal 5.
- (c) Connect the positive (+) lead from the voltmeter to terminal 5 and the negative (—) lead to terminal 4.
- (d) Check that the voltage rises as the float is moved from the full to empty position.

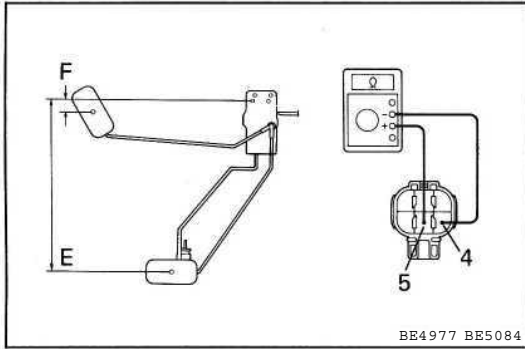

(Resistance)

Measure the resistance between terminals 4 and 5.

Float position	mm (in.)	Resistance (fi)
F	approx. 15 (0.59)	approx. 3
E	approx. 200 (7.87)	approx. 110

If resistance value is not as specified, replace the sender gauge.

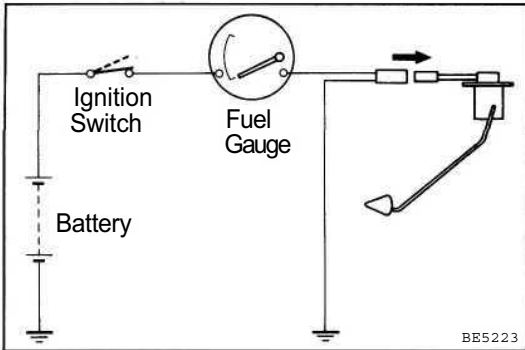

Fuel Gauge System (Sub)

1. INSPECT RECEIVER GAUGE

(Operation)

- (a) Disconnect the connector from the sender gauge.
- (b) Turn the ignition switch ON, check that the receiver gauge needle indicates EMPTY.

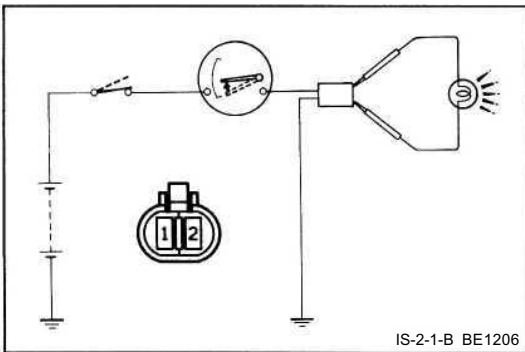

- (c) Connect terminals 1 and 2 on the wire harness side connector through a 3.4 watts test bulb.

- (d) Turn the ignition switch ON, check that the bulb lights up and the receiver gauge needle moves towards the full side.

HINT: Because of the silicon oil in the gauge, it will take a short time for needle to stabilize.

If operation is not as specified, inspect the receiver gauge resistance.

(Resistance)

Measure the resistance between terminals,

(w/ Tachometer)

Between terminals	Resistance (fi)
IGN - Sender	approx. 86
IGN — Ground	approx. 241
Sender — Ground	approx. 155

(w/o Tachometer)

Between terminals	Resistance (0)
IGN - Sender	approx. 123
IGN - Ground	approx. 260
Sender — Ground	approx. 137

If resistance value is not as specified, replace the receiver gauge.

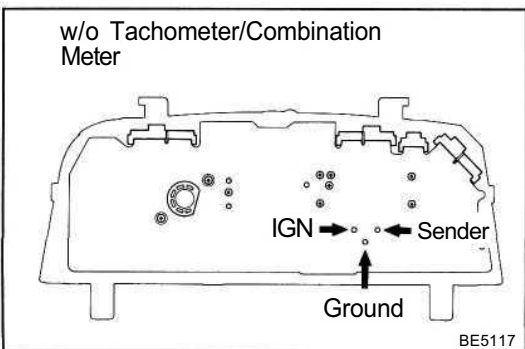
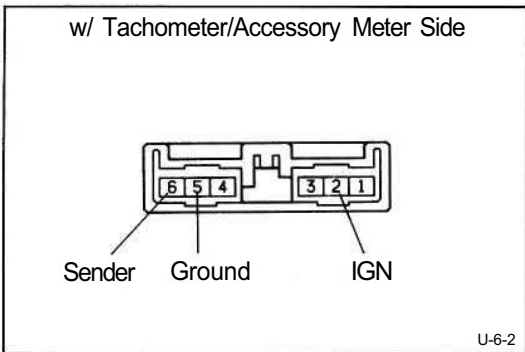

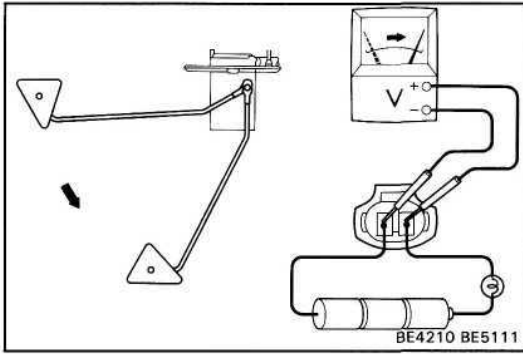

2. INSPECT SENDER GAUGE

(Operation)

- (a) Connect a series of three 1.5 volts dry cell batteries.
- (b) Connect the positive (+) lead from the dry cell batteries to terminal 1 through a 3.4 watts test bulb and the negative (—) lead to terminal 2.
- (c) Connect the positive (+) lead from the voltmeter to terminal 1 and the negative (—) lead to terminal 2.
- (d) Check that the voltage rises as the float is moved from the full to empty position.

(Resistance)

Measure the resistance between terminals 1 and 2.

Float position	mm (in.)	Resistance (fl)
F approx.	53 (2.09)	approx. 3
E approx.	156 (6.14)	approx. 110

If resistance value is not as specified, replace the sender gauge.

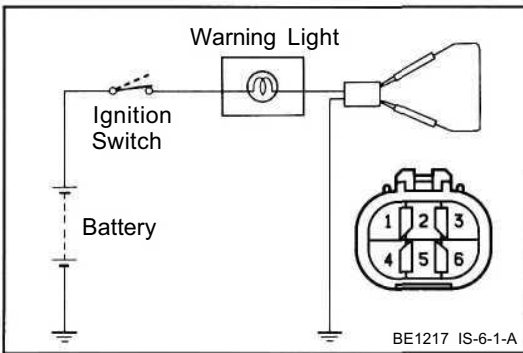
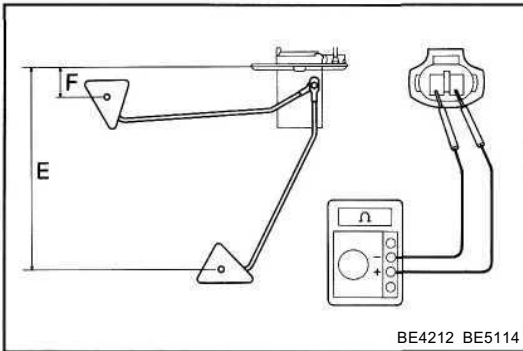

Fuel Level Warning System

1. INSPECT WARNING LIGHT

- (a) Disconnect the connector from the sender gauge.
- (b) Connect terminals 1 and 5 on the wire harness side connector.
- (c) Turn the ignition switch ON, check that the warning light lights up.

If the warning light does not light up, test the bulb.

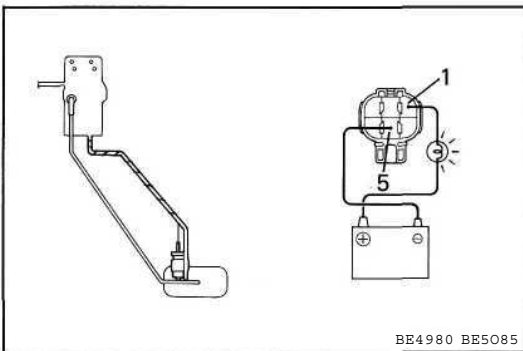

2. INSPECT WARNING SWITCH

- (a) Apply battery voltage between terminals 1 and 5 through a 3.4 watts test bulb, check that the bulb lights up.

HINT: It will take a short time for the bulb to light up.

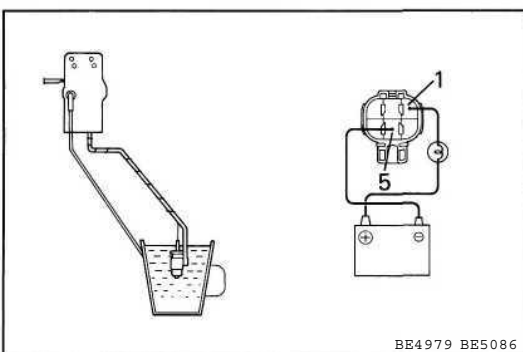

- (b) Submerge the switch in fuel, check that the bulb goes out.

If operation is not as specified, replace the sender gauge.

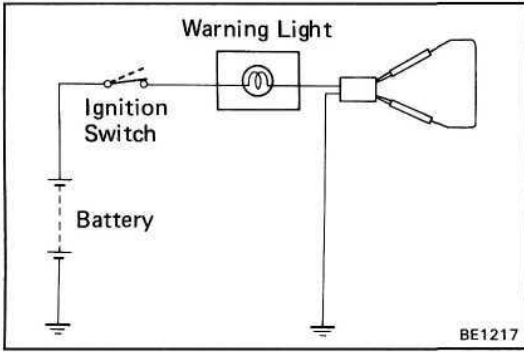

Fuel Filter Warning System

1. INSPECT WARNING LIGHT

- (a) Disconnect the connector from the warning switch and connect terminals on the wire harness side connector.
- (b) Remove the CHARGE fuse and turn the ignition switch ON.
- (c) Check that the warning light lights up and the warning buzzer sounds.

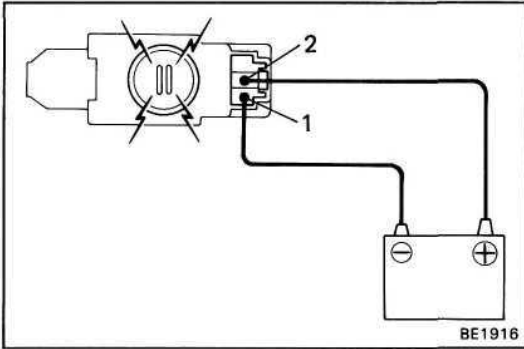

2. INSPECT WARNING BUZZER

Connect the positive (+) lead from the battery to terminal 2 and the negative (-) lead to terminal 1, check that the buzzer sounds.

If buzzer does not sound, replace the buzzer.

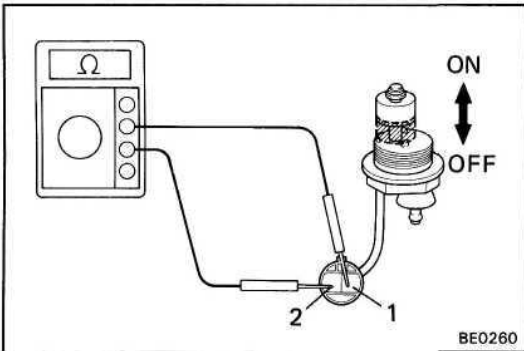

3. INSPECT WARNING SWITCH

- (a) Check that there is no continuity between terminals with the warning switch OFF (float down).
- (b) Check that there is continuity between terminals with the warning switch ON (float up).

If operation is not as specified, replace the switch.

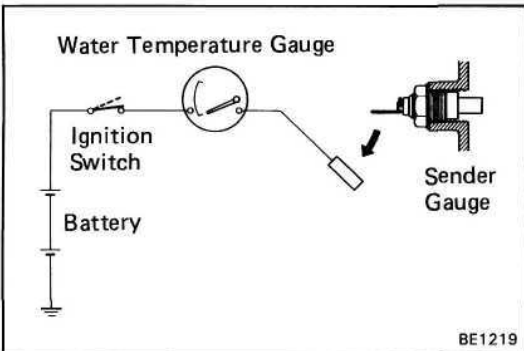

Water Temperature Gauge System

INSPECT RECEIVER GAUGE

(Operation)

- (a) Disconnect the connector from the sender gauge.
- (b) Turn the ignition switch ON, check that the receiver gauge needle indicates COOL.

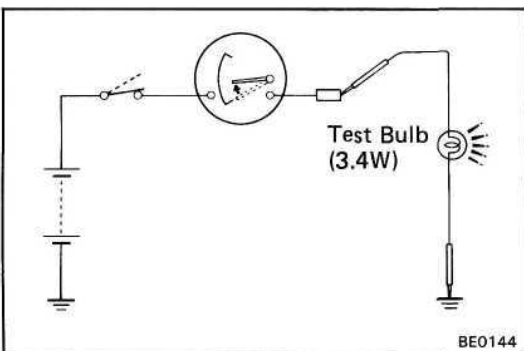

- (c) Ground terminal on the wire harness side connector through a 3.4 watts test bulb.
- (d) Turn the ignition switch ON, check that the bulb lights up and the receiver gauge needle moves to the hot side.

If operation is as specified, replace the sender gauge. Then, recheck system.

If operation is not as specified, measure the receiver gauge resistance.

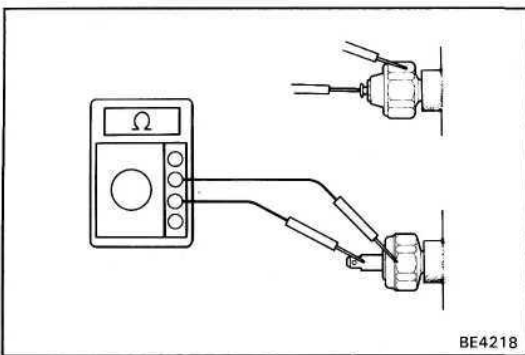
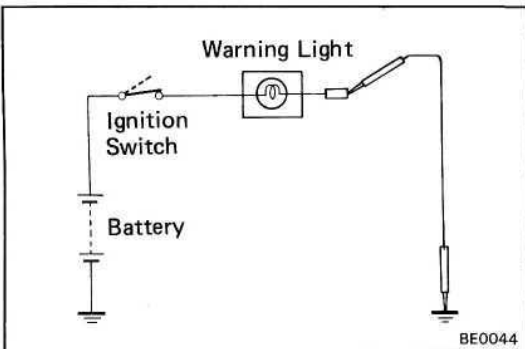
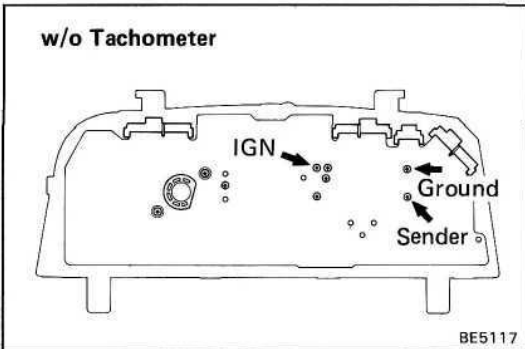
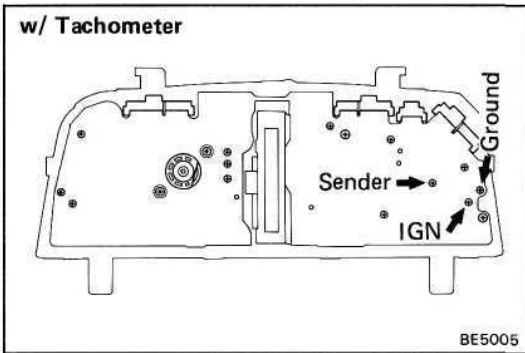

(Resistance)

Measure the resistance between terminals,
(w/ Tachometer)

Between terminals	Resistance (Ω)
IGN – Sender	71 – 79
IGN – Ground	117 – 141
Ground – Sender	185 – 215

(w/o Tachometer)

Between terminals	Resistance (Ω)
IGN – Sender	22 – 28
IGN – Ground	121 – 149
Ground – Sender	22 – 28

HINT: Connect the test leads so that the current from the ohmmeter can flow according to the above order. This circuit include the diode.

If resistance value is not as specified, replace the receiver gauge.

Low Oil Pressure Warning System

1. INSPECT WARNING LIGHT

- (a) Disconnect the connector from the warning switch and ground terminal on the wire harness side connector.
- (b) Turn the ignition switch ON, check that the warning light lights up.

If the warning light does not light up, test the bulb.

2. INSPECT WARNING SWITCH

- (a) Disconnect the connector from the switch.
- (b) Check that there is continuity between terminal and ground with the engine stopped.
- (c) Check that there is no continuity between terminal and ground with the engine running.

HINT: Oil pressure should be over 0.5 kg/cm² (7.1 psi 49 kPa)

If operation is not as specified, replace the switch.

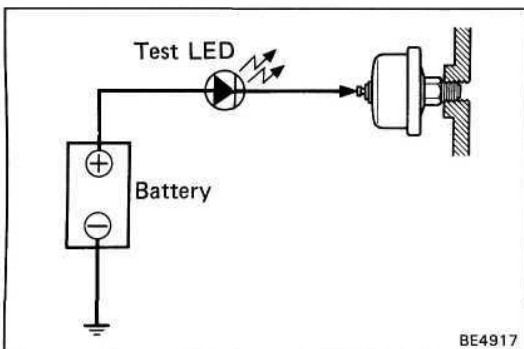
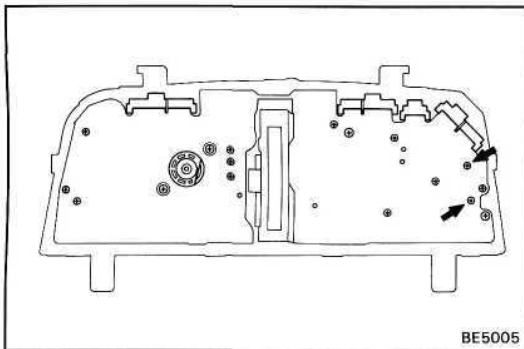
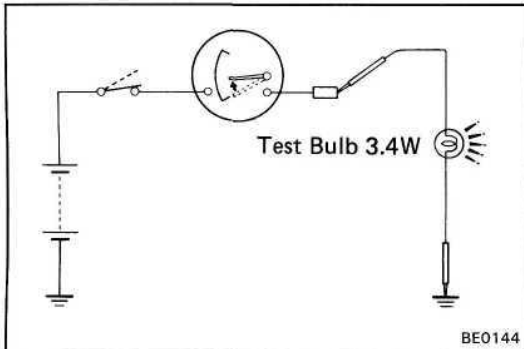
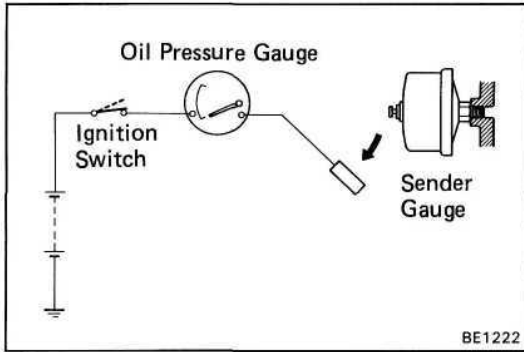

Oil Pressure Gauge System

1. INSPECT RECEIVER GAUGE (Operation)

- Disconnect the connector from the sender gauge.
- Turn the ignition switch ON, check that the receiver gauge needle indicates to the low.

(c) Ground the terminal on the wire harness side through a 3.4 W test bulb.

(d) Turn the ignition switch ON, check that the bulb lights and the receiver gauge needle, moves to the high side.

If operation is not as specified, measure the receiver gauge resistance.

(Resistance)

Measure the receiver gauge resistance between terminals.

Resistance: 22 - 28 Ω

If resistance value is not as specified, replace the receiver gauge.

2. INSPECT SENDER GAUGE

- Disconnect the connector from the sender gauge.
- Apply battery voltage to the sender gauge terminal through a test LED.
- Check that the bulb does not light when the engine is stopped.
- Check that the LED flashes when the engine is running. The number of flashes should vary with engine speed.

If operation is not as specified, replace the sender gauge.

Voltmeter System

INSPECT VOLTMETER

(ON-VEHICLE)

Compare the tester and voltmeter indications.

If error is excessive, replace the voltmeter.

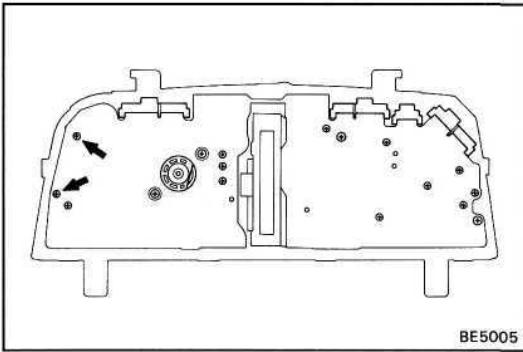

(Resistance)

Measure the resistance between terminals.

Resistance: 90 — 110 Q

If resistance value is not as specified, replace the voltmeter.

HINT: This resistance include fuel receiver gauge resistance.

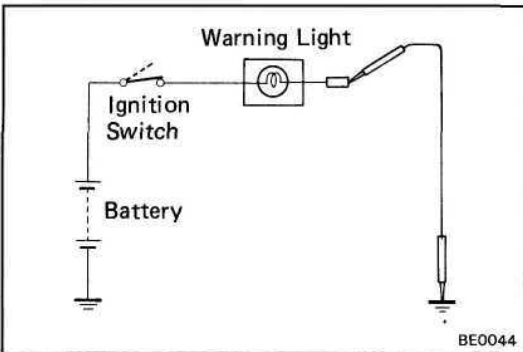

Park Brake Warning System

1. INSPECT WARNING LIGHT

- (a) Disconnect the connector from the parking brake switch and ground terminal on the wire harness side connector.
- (b) Turn the ignition switch ON, check that the warning light lights up.

If the warning light does not light up, test the bulb.

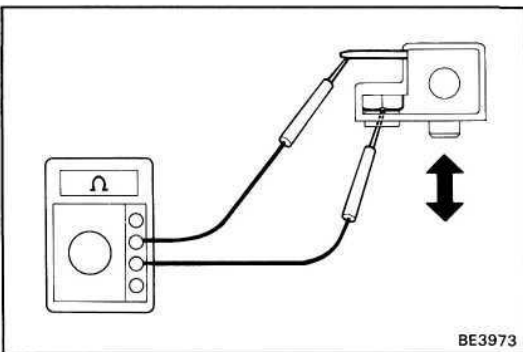

2. INSPECT SWITCHES

- (a) Check that there is continuity between terminal and the switch set nut with switch pin released, (parking brake lever pulled up)
- (b) Check that there is no continuity between terminal and the switch set nut with switch pin pushed in. (parking brake lever released)

If operation is not as specified, replace the switch.

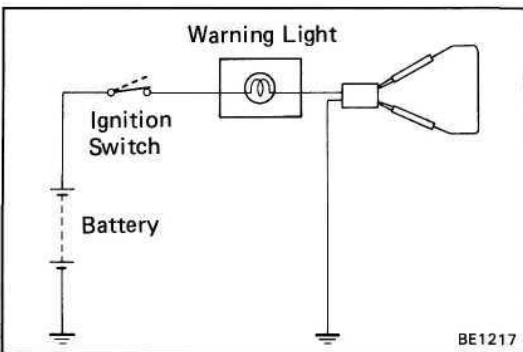

Brake Warning System

1. INSPECT WARNING LIGHT

- (a) (w/o Park Brake Warning System)
Disconnect the connectors from the level warning switch, parking brake switch and (Diesel Engine) vacuum warning switch.
- (w/Park Brake Warning System)
Disconnect the connectors from the level warning switch and (Diesel Engine) vacuum warning switch.
- (b) Connect terminals on the wire harness side connector of the level warning switch connector.
- (c) Turn the ignition switch ON, check that the warning light lights up.

If the warning light does not light up, test the bulb.

2. INSPECT SWITCHES

(Parking Brake Switch: w/o Park Brake Warning System)

See step 2 on page BE-63.

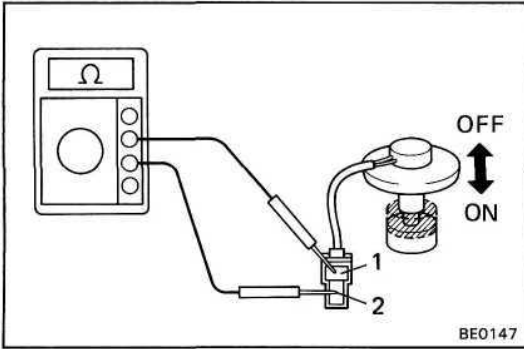

(Brake Fluid Level Warning Switch)

- (a) Check that there is no continuity between terminals with the switch OFF (float up).
- (b) Check that there is continuity between terminals with the switch ON (float down).

If operation is not as specified, replace the switch.

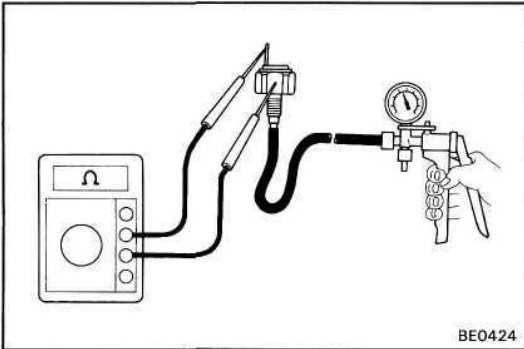

(Vacuum Warning Switch: Diesel Engine)

- (a) Check that there is continuity between terminal and the switch body with a no vacuum.
- (b) Apply 200 ± 40 mmHg (7.87 ± 1.57 in.Hg, 26.7 ± 5.3 kPa) of pressure.
- (c) Check that there is no continuity between terminal and the switch body.

If operation is not as specified, replace the switch.

3. INSPECT RELAY

(Bulb Check Relay: Australia/Continuity)

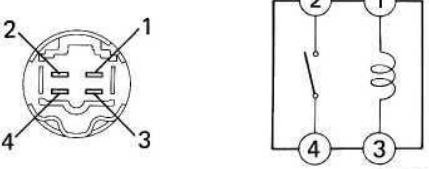

Terminal Condition	1	2	3	4
Constant	○	—(coil)—	○	
Apply battery voltage to terminals 1 and 3.		○		○

If continuity is not as specified, replace the relay.

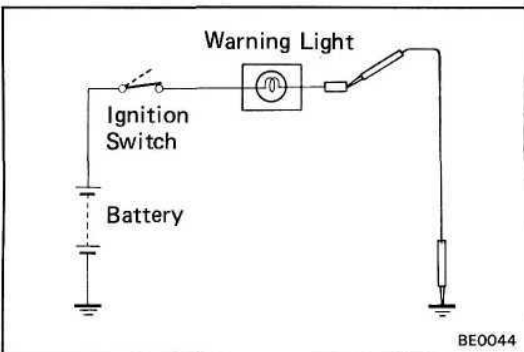

Open Door Warning System

1. INSPECT WARNING LIGHT

- (a) Disconnect the connector from the door courtesy switch and ground terminal on the wire harness side connector.
- (b) Turn the ignition switch ON, check that the warning light lights up.

If the warning light does not light up, test the bulb.

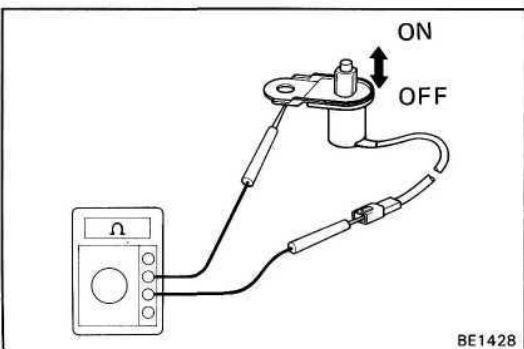

2. INSPECT COURTESY SWITCH

- (a) Check that there is continuity between terminal and the switch body with the ON (switch pin released: opened door).
- (b) Check that there is no continuity between terminal and the switch body with the OFF (switch pin pushed in: closed door).

If operation is not as specified, replace the switch.

Seat Belt Warning System

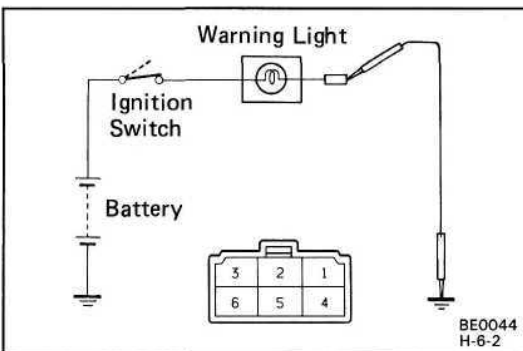
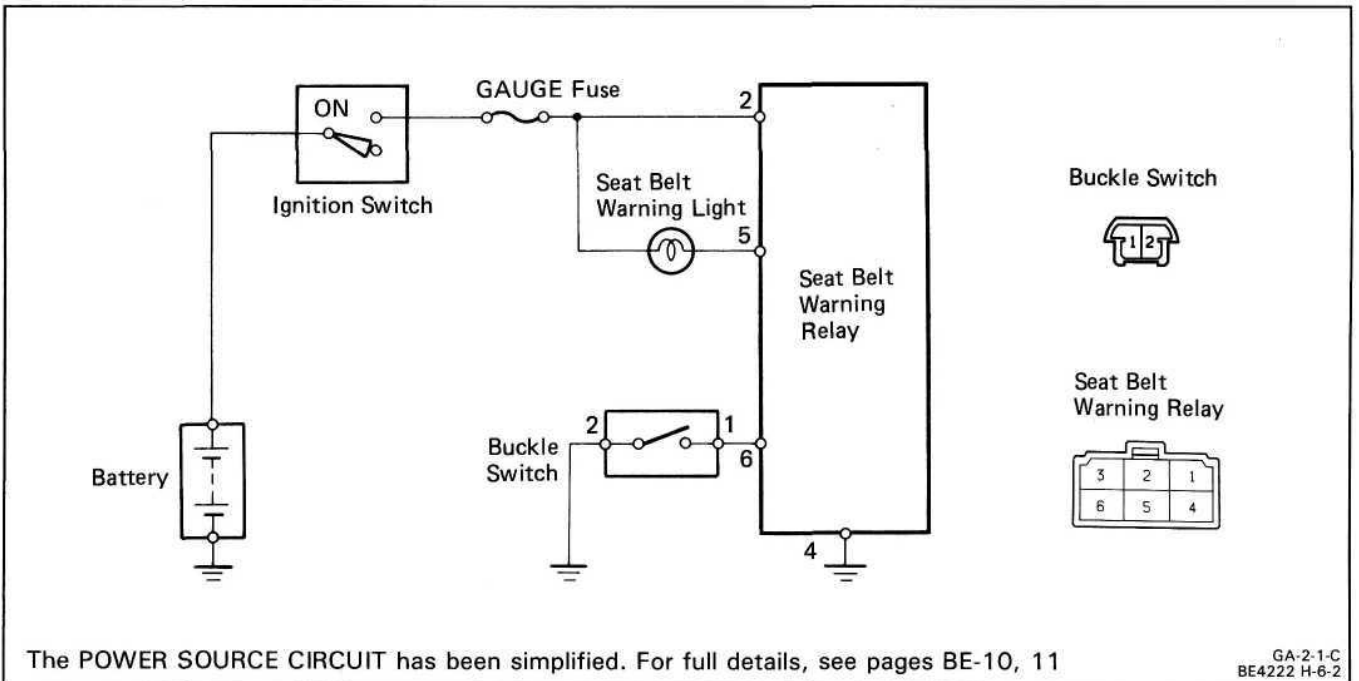

1. INSPECT WARNING LIGHT

- (a) Disconnect the connector from the seat belt warning relay.
- (b) Ground terminal 5 on the wire harness side connector.
- (c) Turn the ignition switch ON, check that the warning light lights up.

If the warning light does not light, test the bulb.

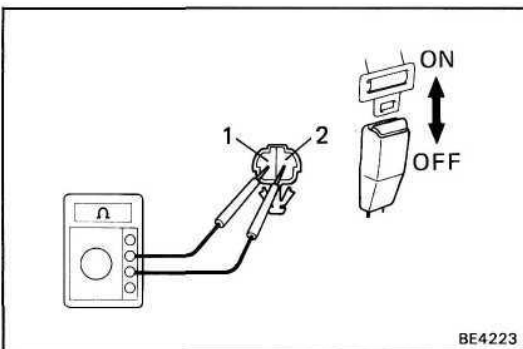

2. INSPECT SWITCHES (Buckle Switch)

- (a) Check that there is no continuity between terminals with the switch ON (belt unfastened).
- (b) Check that there is continuity between terminals with the switch OFF (belt fastened).

If operation is not as specified, replace the seat belt inner.

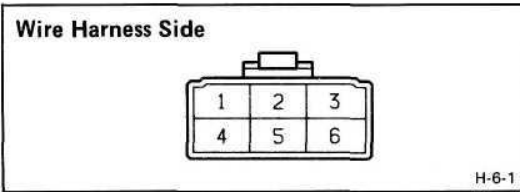

3. INSPECT SEAT BELT RELAY (Relay Circuit)

Disconnect the connector from the relay and inspect the connector on the wire harness side as shown in the chart.

Check for	Tester connection	Condition		Specified value
Continuity	4 - Ground	Constant		Continuity
	6 - Ground	Buckle switch position	ON (Belt fastened)	No continuity
OFF (Belt unfastened)			Continuity	
Voltage	2 - Ground	Ignition switch position	LOCK or ACC	No voltage
			ON	Battery voltage
	5 - Ground	Ignition switch position	LOCK or ACC	No voltage
			ON	Battery voltage

If circuit is as specified, replace the relay.

If circuit is not as specified, refer to BE-65 wiring diagram and inspect the circuits connected to other parts.

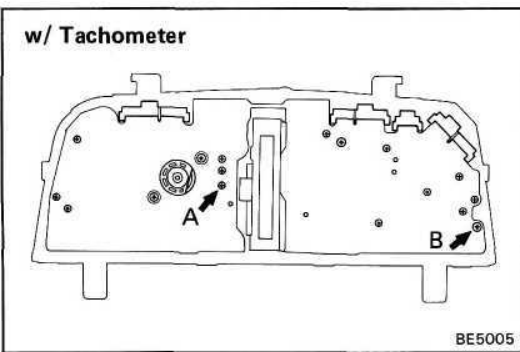

Timing Belt Warning System

1. INSPECT WARNING LIGHT

- (a) Remove the combination meter with connectors connected.
- (b) Connect terminals A and B.
- (c) Remove CHARGE fuse and turn the ignition switch ON, check that the warning light lights up.

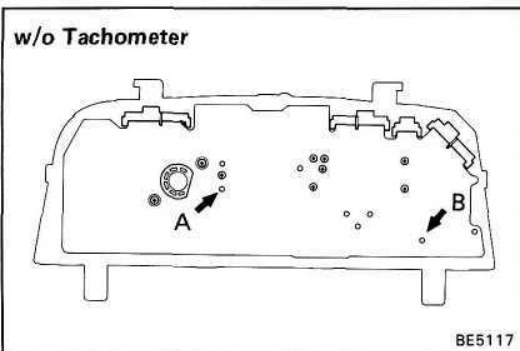

If the warning light does not light up, test the bulb.

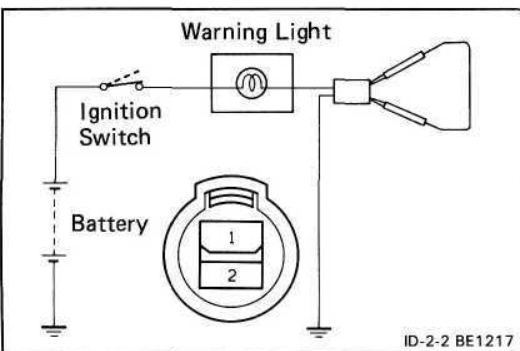

Air Cleaner Warning System

1. **INSPECT CHARGE LIGHT** to verify the bulb is functional.

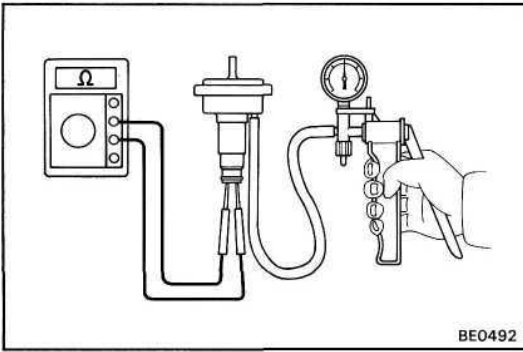

2. INSPECT VACUUM SWITCH

- (a) With a vacuum of 29.4 ± 3.7 mmHg (1.157 ± 0.146 in.Hg, 3.9 ± 0.5 kPa) or above, check that there is continuity between terminals.
- (b) Check that there is no continuity between terminals with no vacuum.

If operation is not as specified, replace the switch.

Meter Illumination Control System

INSPECT LIGHT CONTROL RHEOSTAT

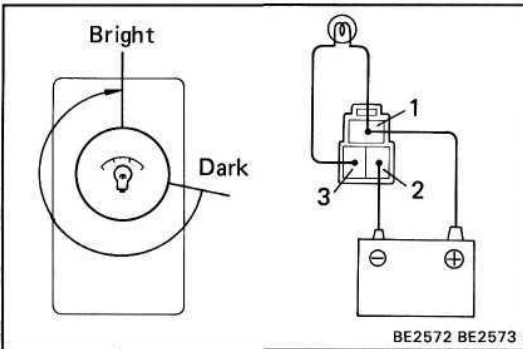

- (a) Connect terminals 1 and 3 through a 3.4 watts test bulb.
- (b) Connect the positive (+) lead from the battery to terminal 1 and the negative (-) lead to terminal 2.
- (c) Gradually turn the rheostat knob to clockwise, check that the test bulb brightness changes from dark to bright.

If operation is not as specified, replace the rheostat.

Turbo Indicator and Warning System

1. INSPECT INDICATOR AND WARNING LIGHT OPERATION (Refer to EM Section of ENGINE Repair Manual)

2. INSPECT PRESSURE SWITCH OPERATION

- (a) At the 3-way union, disconnect the pressure hose from the compressor elbow and connect a turbocharger pressure gauge (SST).

SST 09992-00241

- (b) Check that the low and high pressure switch are continuity between terminals as shown in the chart.

(High Pressure Switch)

Terminal Condition	1	2	3
No pressure	○	○	
Apply 0.84 kg/cm^2 (11.9 psi, 82.4 kPa) of pressure			

(Low Pressure Switch)

Terminal Condition	1	2	3
No pressure		○	○
Apply 0.14 kg/cm^2 (2.0 psi, 13.7 kPa) of pressure			

If operation is not as specified, replace the switch.

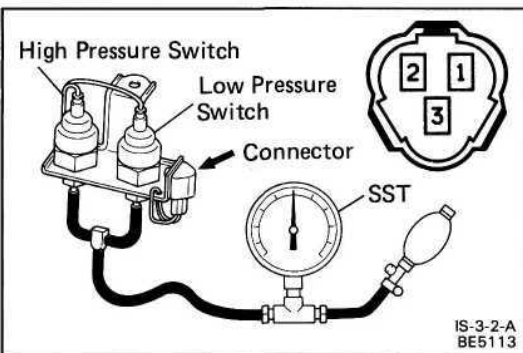

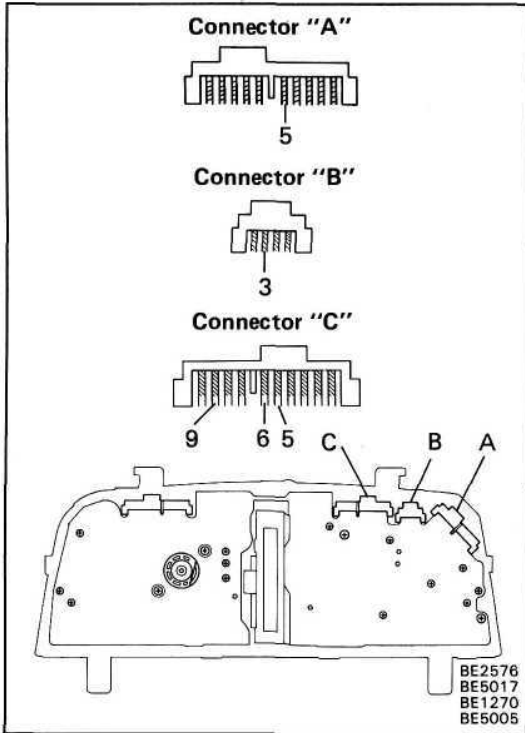

3. INSPECT TURBO INDICATOR AND WARNING LIGHT DRIVE CIRCUIT

- (a) Remove the Combination Meter.
- (b) Connect the positive (+) lead and negative (—) lead from the battery to combination meter terminals as shown in the chart and check that the LED operation.

Condition	Positive (+) Combination meter terminal	Negative (—) Combination meter terminal	LED condition	
			Green	Ammbber
1	(A5)	(B3, C5, C6, C9)	OFF	OFF
2	(A5)	(B3, C5, C9)	ON	OFF
3	(A5)	(B3, C9)	OFF	ON
4	(A5)	(B3, C6, C9)	OFF	ON
5	(A5)	(B1, B3, C9)	ON	ON

If operation is not as specified, replace the combination meter.

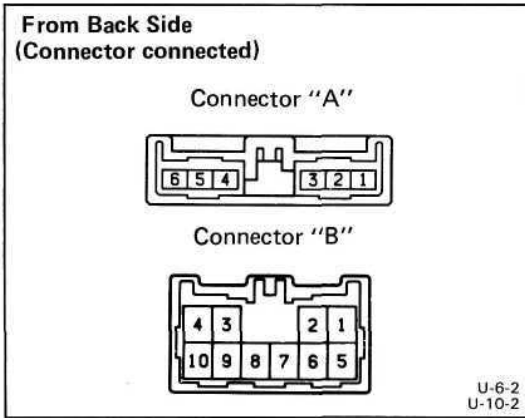

Compass System

1. INSPECT ACCESSORY METER (Circuit)

Connect connector "A" and "B" to accessory meter and inspect connectors from the back side as shown in the chart.

NOTICE: Perform the inspection in a place free from magnetic influence.

Terminal Name	Check for	Tester connection	Condition	Specified value	
ACC	Voltage	A1 – A4	Ignition switch turned to ACC or ON	10 – 14 V	
TAIL		A3 – A4	Light control switch turned to TAIL or HEAD	10 – 14 V	
GROUND	Continuity	A4 – Ground	Constant	Continuity	
GND		B4 – Ground	Constant	Continuity	
ACC	Voltage	B6 – B4	Ignition switch turned to ACC or ON	10 – 14 V	
HX1		B5 – B4	Knob "N" position	Turned fully counter clockwise	6.2 – 6.8 V
				Neutral	3.7 – 4.3 V
				Turned full clockwise	1.2 – 1.8 V
			Knob "E" turned to clockwise and knob "N" turned to neutral position		3.7 – 4.3 V
HY2		B8 – B4	Knob "N" position	Turned fully counter clockwise	0.54 – 0.56 V
				Neutral	0.53 – 0.55 V
				Turned fully clockwise	0.49 – 0.50 V
			Knob "E" turned to clockwise and knob "N" turned to neutral position		0.53 – 0.55 V
HX2		B9 – B4	Knob "N" position	Turned fully counter clockwise	0.54 – 0.56 V
				Neutral	0.53 – 0.55 V
				Turned fully clockwise	0.49 – 0.51 V
	Knob "E" turned to clockwise and knob "N" turned to neutral position		0.53 – 0.55 V		
HY1	B10 – B4	Knob "N" position	Turned fully counter clockwise	6.2 – 6.8 V	
			Neutral	3.7 – 4.3 V	
			Turned fully clockwise	1.2 – 1.8 V	
		Knob "E" turned to clockwise and knob "N" turned to neutral position		3.7 – 4.3 V	

If the circuit is not as specified, refer to BE-51 wiring diagram and inspect the circuits connected to other parts or wire harness.

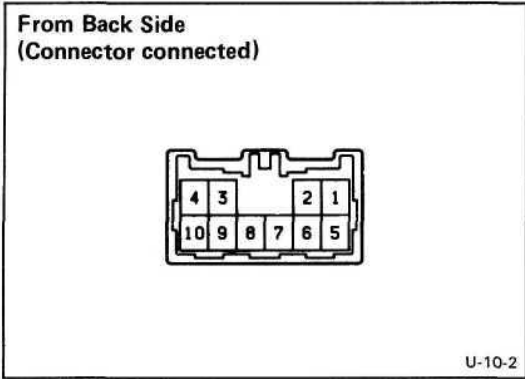
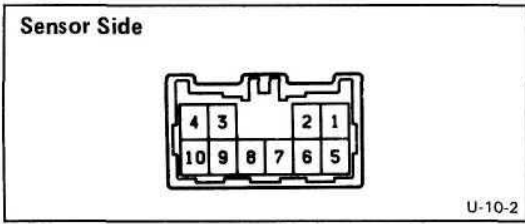

2. INSPECT MAGNET FIELD SENSOR (Resistance)

Measure the resistance between terminals B5 and B9.

Resistance: 81 — 111 Q

If resistance value is not as specified, replace the sender gauge.

(Circuit)

Connect connector to sensor and inspect connector from the back side as shown in the chart.

Terminal Name	Check for	Tester connection	Condition	Specified value	
SX	Voltage	1 — 4	Face the car north, then turn the car in a circle.	Facing North	Approx. 4.2 V
				Facing East	Approx. 4.0 V
				Facing South	Approx. 3.8 V
				Facing West	Approx. 4.0 V
SY		2 — 4	Face the car north, then turn the car in a circle.	Facing North	Approx. 4.0 V
				Facing East	Approx. 3.8 V
				Facing South	Approx. 4.0 V
				Facing West	Approx. 4.2 V
VDD		3 — 4	Ignition switch turned to ACC	Approx. 8.0 V	
ACC		6 — 4	Ignition switch turned to ACC	10 — 14 V	
VSS		7 — 4	Ignition switch turned to ACC	Approx. 4.0 V	
GND	Continuity	4 — Ground	Constant	Continuity	

If circuit is not as specified, refer to BE-51 wiring diagram and inspect the circuits connected to other parts or wire harness.

DEFOGGER SYSTEM

Parts Location

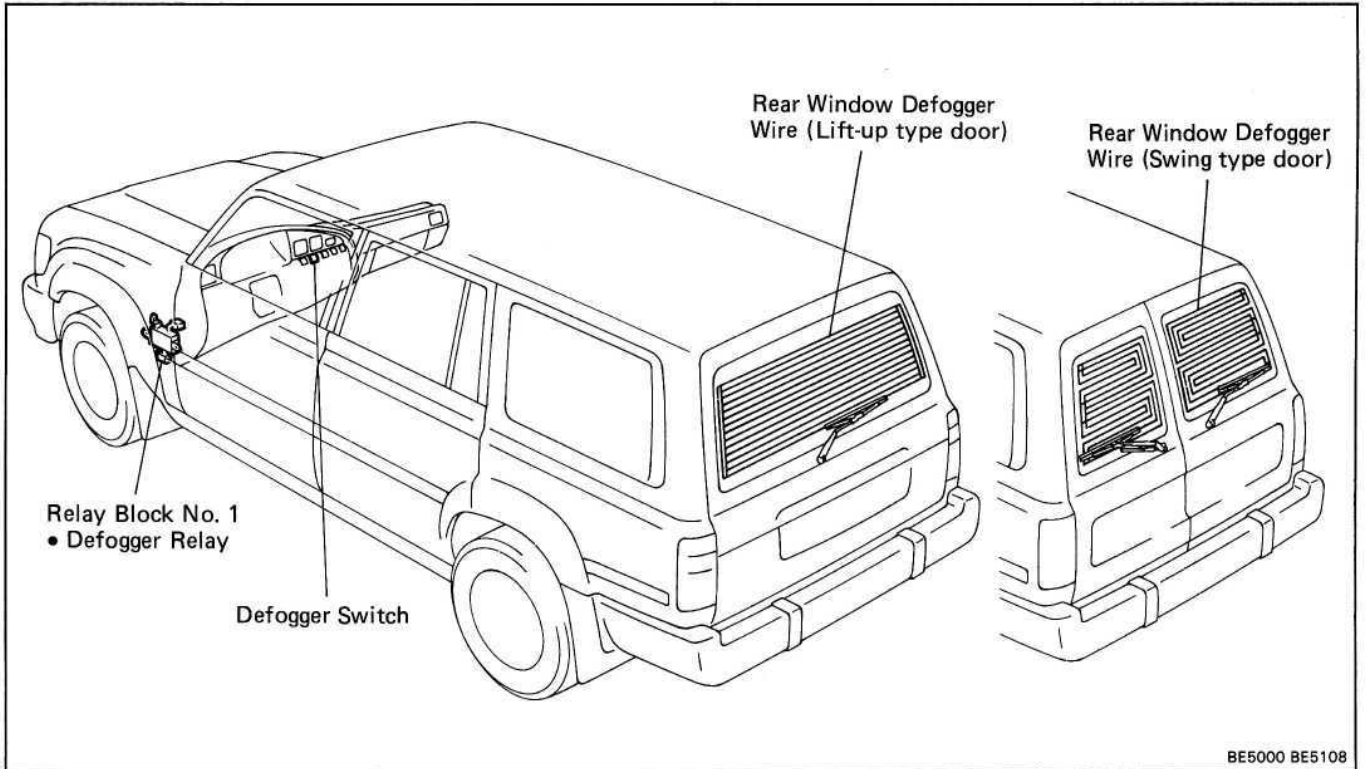

BE5000 BE5108

Wiring and Connector Diagrams

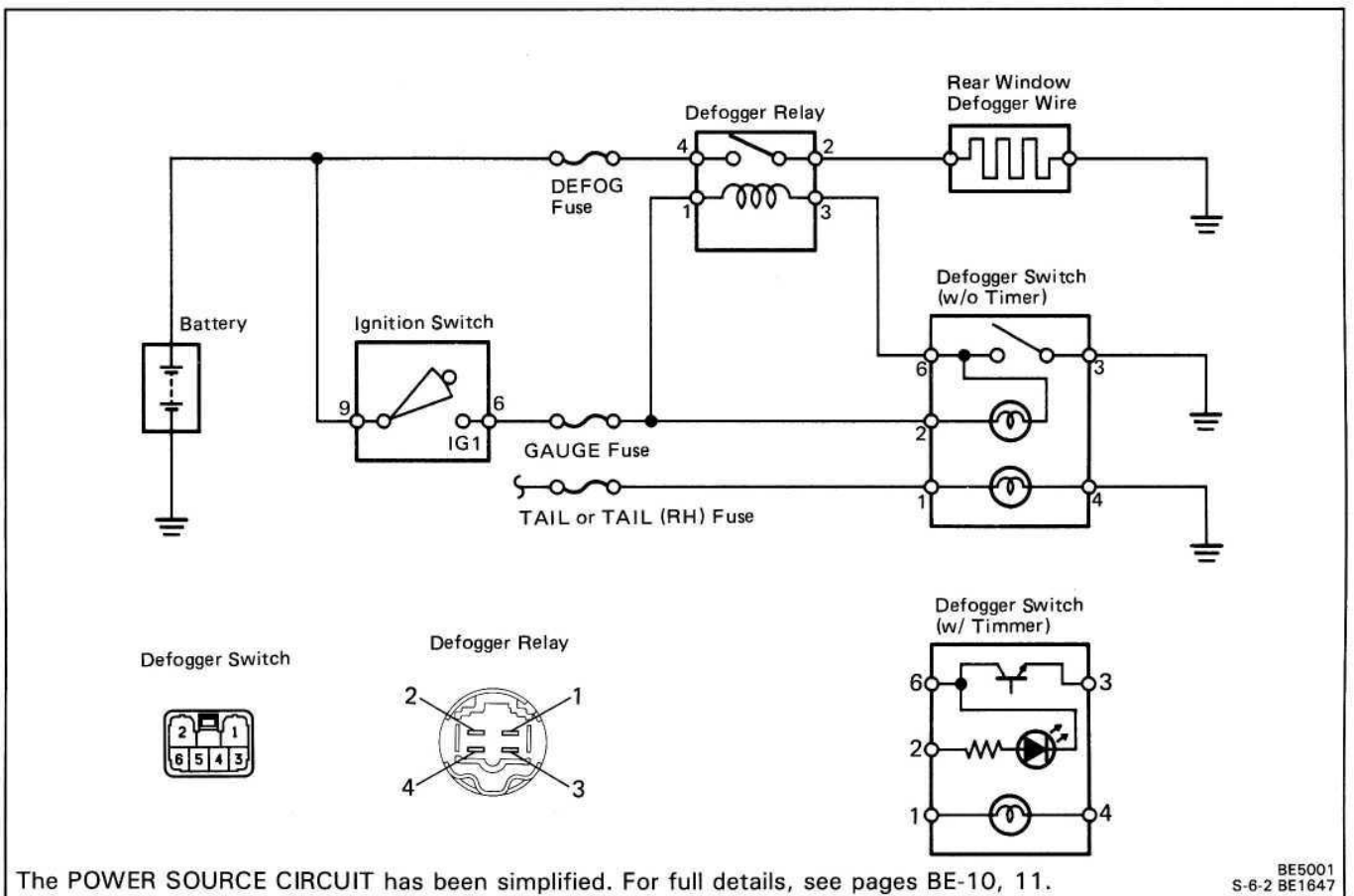

The POWER SOURCE CIRCUIT has been simplified. For full details, see pages BE-10, 11.





BE5001
S-6-2 BE1647

Troubleshooting

Problem	Possible cause	Remedy	Page
Rear window defogger system do not operate	DEFOG fuse blown	Replace fuse and check for short	BE-4, 6
	GAUGE fuse blown	Replace fuse and check for short	BE-4, 6
	Defogger switch faulty	Check switch	BE-72
	Defogger relay faulty	Check relay	BE-73
	Defogger wire broken	Check wires	BE-73
	Wiring or ground faulty	Repair as necessary	

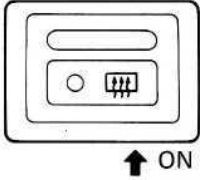
Parts Inspection

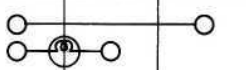
1-1. (w/o Timer) INSPECT DEFOGGER SWITCH (Continuity)

  <small>BE4995 S-6-2</small>	Terminal	2	3	6	Illumination	
	Switch position				1	4
	OFF					
ON						

If continuity is not as specified, check the bulb or replace the switch.

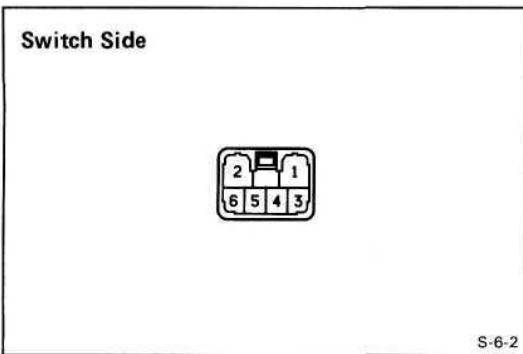

1-2. (w/ Timer) INSPECT DEFOGGER SWITCH (Illumination Light/Continuity)

Check that there is continuity between terminals 1 and 4.
If continuity is not as specified, check the bulb.

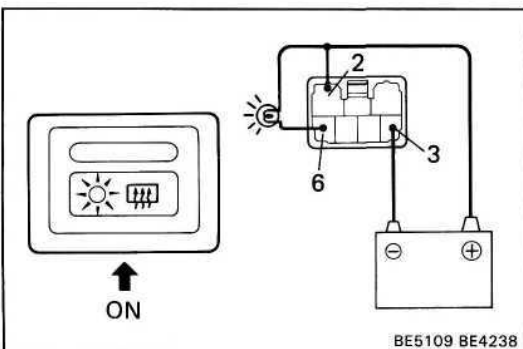

(Timer Operation)

- Connect the positive (+) lead from the battery to terminals 2 and the negative (—) lead to terminal 3.
 - Connect the positive (+) lead from the battery to terminals 6 through a 3.4 watts test bulb.
 - Push the defogger switch ON, check that the indicator light and test bulb lights up for 12 to 18 minutes, then the indicator light and test bulb lights goes out.
- If operation is not as specified, replace the switch.

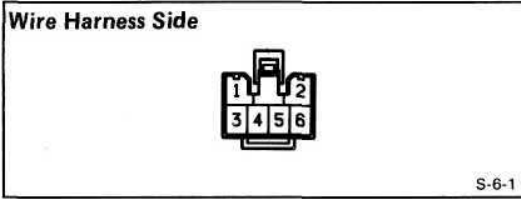

(Timer Circuit)

Disconnect the connector from the switch and inspect the connector on the wire harness side as shown in the chart.

Check for	Tester connection	Condition		Specified value
Continuity	3 – Ground	Constant		Continuity
Voltage	2 – Ground	Ignition switch position	LOCK or ACC	No voltage
			ON	Battery voltage
	6 – Ground	Ignition switch position	LOCK or ACC	No voltage
			ON	Battery voltage
Operation	—	Connect the terminals 6 and 3		Defogger system operation is normal

If the circuit is as specified, replace the switch.

2. INSPECT DEFOGGER RELAY (Continuity)

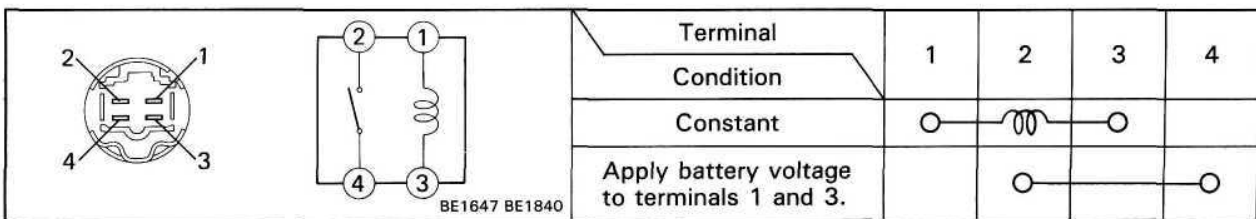

If continuity is not as specified, replace the relay.

3. INSPECT DEFOGGER WIRES

NOTICE:

- When cleaning the glass, use a soft, dry cloth, and wipe the glass in the direction of the wire. Take care not to damage the wires.
- Do not use detergents or glass cleaners with abrasive ingredients.
- When measuring voltage, wind a piece of tin foil around the top of the negative (—) probe and press the foil against the wire with your finger as shown.

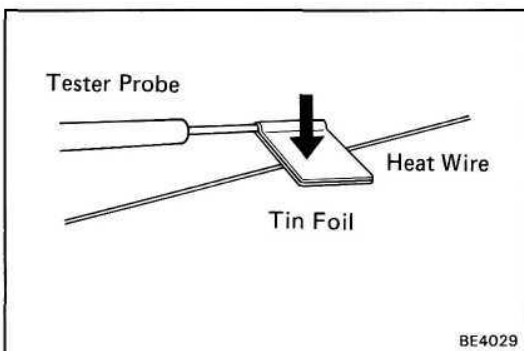

(Wire Breakage)

- Turn the ignition switch ON.
- Push in the defogger switch.
- Inspect the voltage at the center of each heat wire as shown.

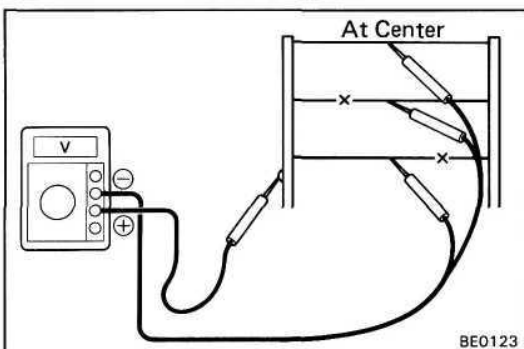

Voltage	Criteria
approx. 5 V	Okey (No break in wire)
approx. 10 V or 0 V	Broken wire

HINT: If there is 10 V, the wire is broken between the center of the wire and positive (+) end. If there is no voltage, the wire is broken between the center of the wire and ground.

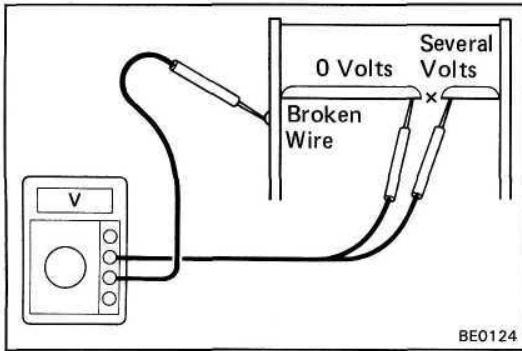
**(Wire Breakage Point)**

- Place the boltmeter positive (+) lead against the defogger positive (+) terminal.
- Place the boltmeter negative (-) lead with the foil strip against the heat wire at the positive (+) terminal end and slide it toward the negative (-) terminal end.
- The point where the voltmeter deflects from zero to several volts is the place where the heat wire is broken.

HINT: If the heat wire is not broken, the voltmeter indicates 0 volts at the positive (+) end of the heat wire but gradually increases to about 12 volts as the meter probe is moved to the other end.

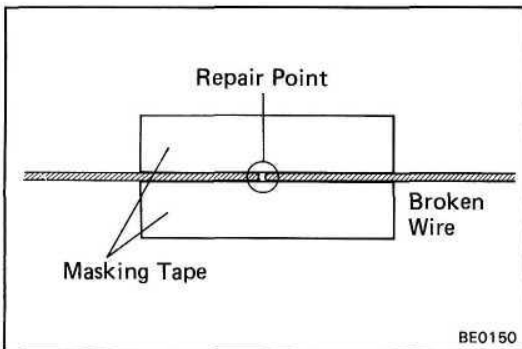
**4. REPAIR DEFOGGER WIRES**

- Clean the broken wire tips with a grease, wax and silicone remover.
- Place the masking tape along both sides of the wire to be repaired.

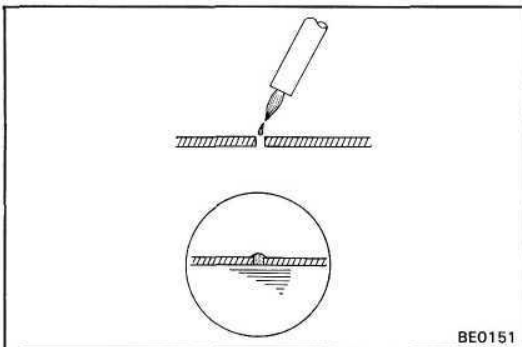

- Thoroughly mix the repair agent (Dupont paste No.4817 or equivalent).
- Using a fine tip brush, apply a small amount to the wire.
- After a few minutes, remove the masking tape.
- Allow the repair to stand at least 24 hours.

POWER WINDOW CONTROL SYSTEM

Parts Location

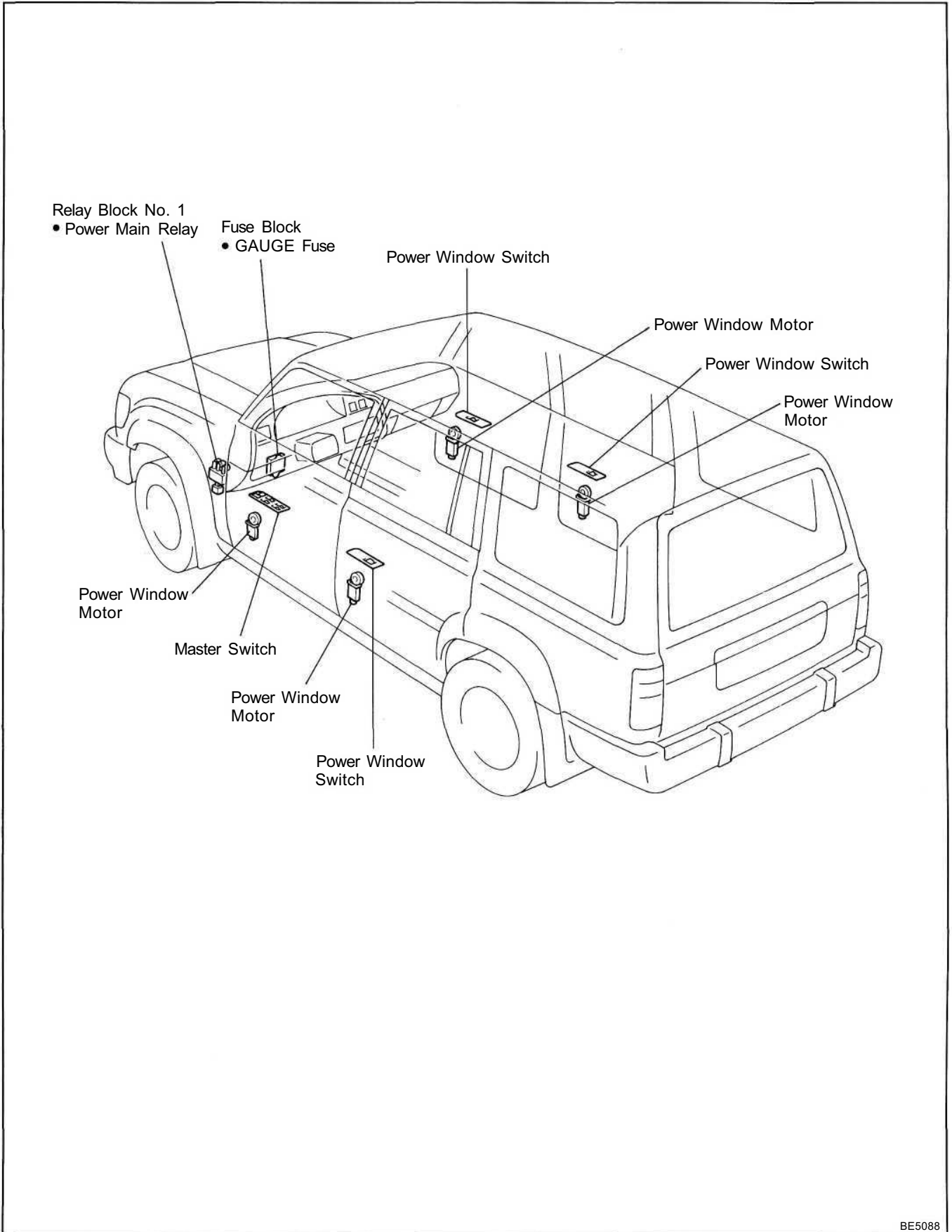

Wiring and Connector Diagrams

HINT: The numbers in () mean for RHD vehicles.

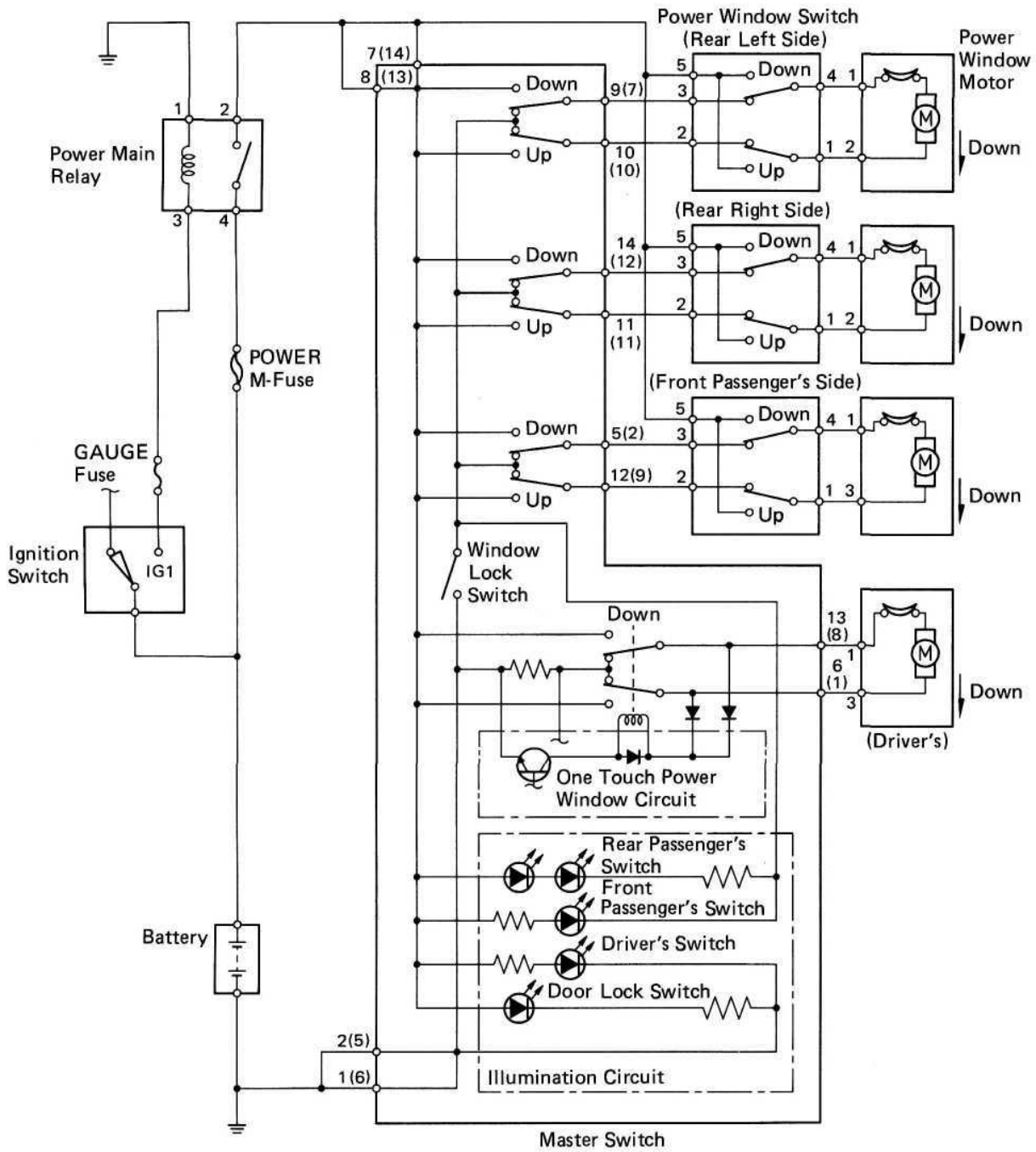

Master Switch

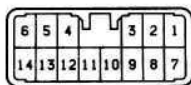

Power Window Switch



Power Window Motor
(Front) (Rear)

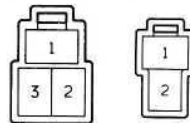

Power Main Relay

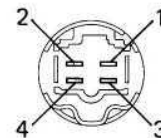

The POWER SOURCE CIRCUIT has been simplified. For full details, see pages BE-10, 11.

Troubleshooting

Problem	Possible cause	Remedy	Page
Power window does not operate at all	GAUGE fuse blown POWER fuse blown Power main relay faulty Wiring or ground faulty	Replace fuse and check for short Replace fuse and check for short Check relay Repair as necessary	BE-4,6 BE-4,6 BE-82
One-touch power window does not operate	Power window master switch faulty	Check switch	BE-77
Only one window does not operate	Power window master switch faulty Power window switch faulty Power window motor faulty Wiring or ground faulty	Check switch Check switch Check motor Repair as necessary	BE-77 BE-80 BE-80

Parts Inspection

1. INSPECT SWITCHES (Master Switch/Continuity)

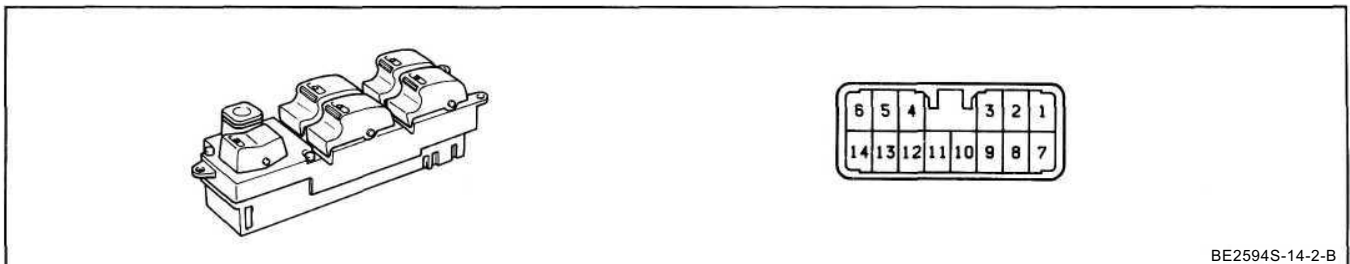

BE2594S-14-2-B

Window operation		Front								Rear							
		Driver's				Passenger's				Left				Right			
Terminal	LHD	1 or 2	6	7 or 8	13	1 or 2	5	7 or 8	12	1 or 2	7 or 8	9	10	1 or 2	7 or 8	11	14
Switch position	RHD	5 or 6	1	13 or 14	8	5 or 6	2	13 or 14	9	5 or 6	13 or 14	7	10	5 or 6	13 or 14	11	12
Window unlock	UP	○	○	○	○	○	○	○	○	○	○	○	○	○	○	○	○
	OFF	○	○	○	○	○	○	○	○	○	○	○	○	○	○	○	○
	DOWN	○	○	○	○	○	○	○	○	○	○	○	○	○	○	○	○
Window lock	UP	○	○	○	○	○	○	○	○	○	○	○	○	○	○	○	○
	OFF	○	○	○	○	○	○	○	○	○	○	○	○	○	○	○	○
	DOWN	○	○	○	○	○	○	○	○	○	○	○	○	○	○	○	○

If continuity is not as specified, replace the master switch.

(Master Switch: Illumination/Operation)

LHD:

- Set the window lock switch to the unlock position.
- Connect the positive (+) lead from the battery to terminal 7 and the negative (-) lead to terminal 1, check that all the illuminations light up.

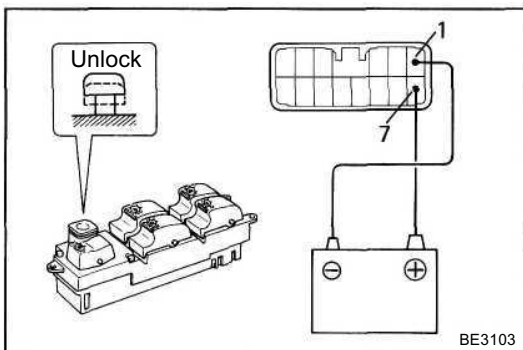

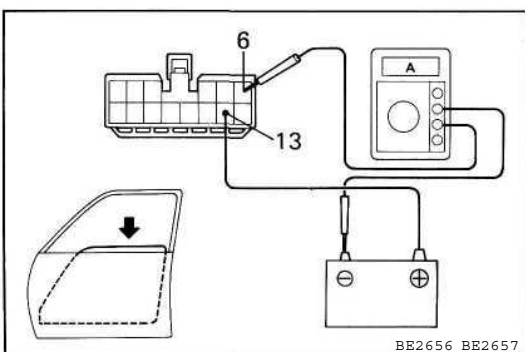
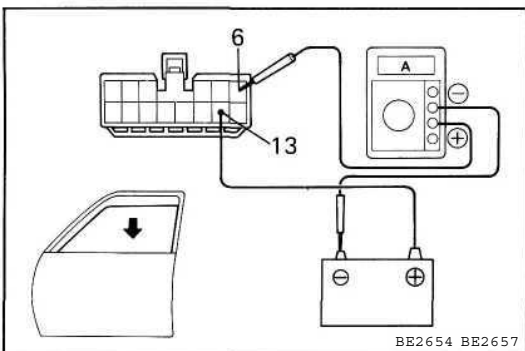
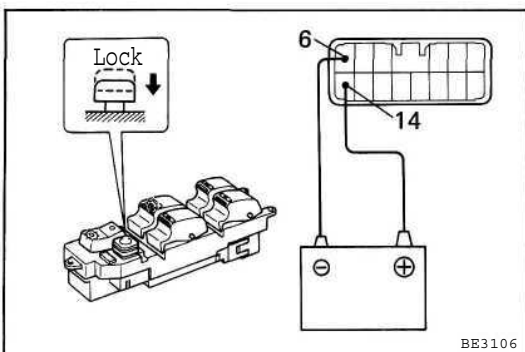
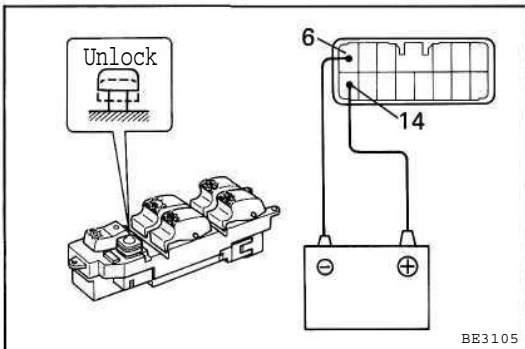
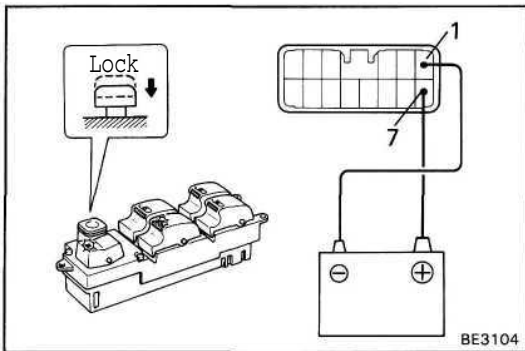

- (c) Set the window lock switch to the lock position, check that the passenger's illumination go out.

If operation is not as specified, replace the master switch.

RHD:

- (a) Set the window lock switch to the unlock position.
 (b) Connect the positive (+) lead from the battery to terminal 14 and the negative (-) lead to terminal 6, check that all the illuminations light up.

- (c) Set the window lock switch to the lock position, check that all the passenger's illuminations go out.

If operation is not as specified, replace the master switch.

(Master Switch: One Touch Power Window System/ Current of Circuit)

LHD:

Inspection using an ammeter

- (a) Disconnect the connector from the master switch.
 (b) Connect the positive (+) lead from the ammeter to terminal 6 on the wire harness side connector and the negative (-) lead to negative (-) terminal of the battery.
 (c) Connect the positive (+) lead from the battery to terminal 13 on the wire harness side.
 (d) As the window goes down, check that the current flows approximately 7 amperes.
 (e) Check that the current increases approximately 14.5 amperes or more when the window stops going down.

HINT: The circuit breaker opens some 4 — 40 seconds after the window stops going down, so that check must be made before the circuit breaker operates.

If the operation is as specified, replace the master switch.

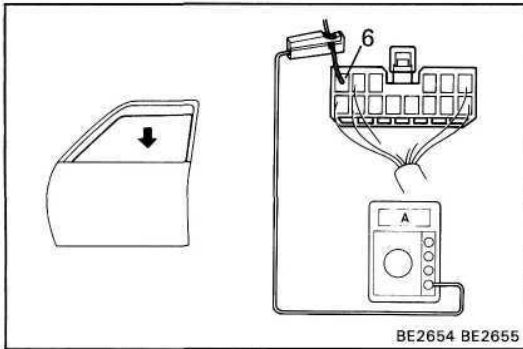

Inspection using an ammeter with a current-measuring probe.

- (a) Remove the master switch with connector connected.
- (b) Attach a current-measuring probe to terminal 6 of the wire harness.
- (c) Turn the ignition switch ON and set the power window switch in the down position.
- (d) As the window goes down, check that the current flows approximately 7 amperes.

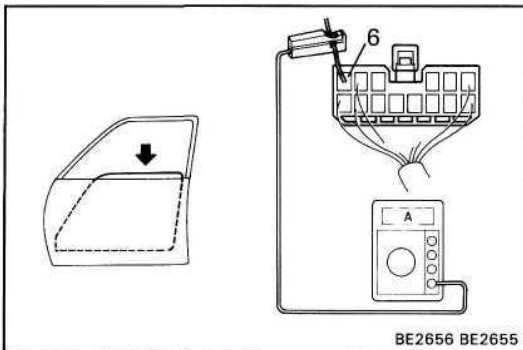

- (e) Check that the current increases approximately 14.5 amperes or more when the window stops going down.

HINT: The circuit breaker opens some 4 — 40 seconds after the window stops going down, so that check must be made before the circuit breaker operates.

If operation is as specified, replace the master switch.

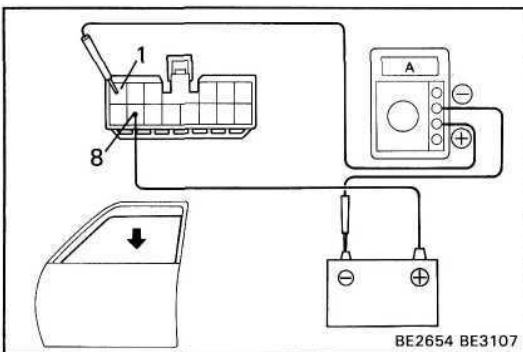

RHD:

Inspection using an ammeter

- (a) Disconnect the connector from the master switch.
- (b) Connect the positive (+) lead from the ammeter to terminal 1 on the wire harness side connector and the negative (—) lead to negative (—) terminal of the battery.
- (c) Connect the positive (+) lead from the battery to terminal 8 on the wire harness side.
- (d) As the window goes down, check that the current flows approximately 7 amperes.
- (e) Check that the current increases approximately 14.5 amperes or more when the window stops going down.

HINT: The circuit breaker opens some 4 — 40 seconds after the window stops going down, so that check must be made before the circuit breaker operates.

If operation is as specified, replace the master switch.

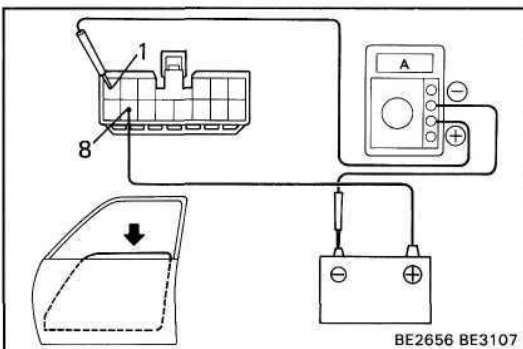

Inspection using an ammeter with a current-measuring probe.

- (a) Remove the master switch with connector connected.
- (b) Attach a current-measuring probe to terminal 1 of the wire harness.
- (c) Turn the ignition switch ON and set the power window switch in the down position.
- (d) As the window goes down, check that the current flows approximately 7 amperes.

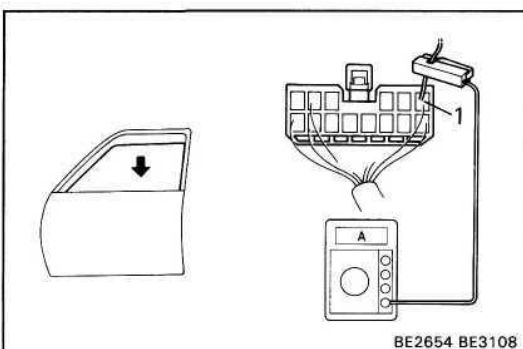

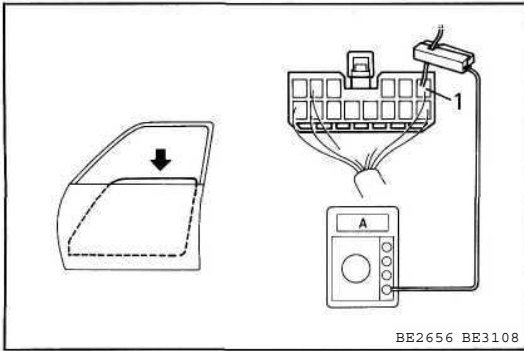

(e) Check that the current increases approximately 14.5 amperes or more when the window stops going down.

HINT: The circuit breaker opens some 4 — 40 seconds after the window stops going down, so that check must be made before the circuit breaker operates.

If operation is as specified, replace the master switch.

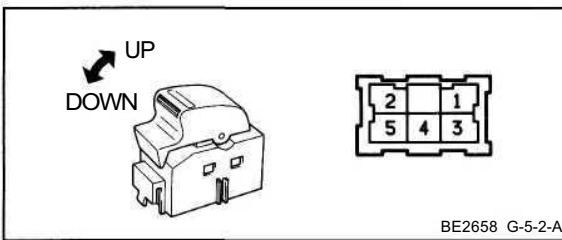

Terminal	1	2	3	4	5
Switch position (Power Window Switch/Continuity)					
UP	○		○	○	○
OFF	○	○	○	○	
DOWN	○	○		○	○

If continuity is not as specified, replace the switch.

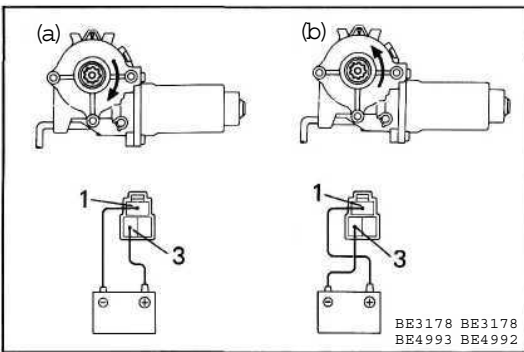

2. INSPECT POWER WINDOW MOTOR (Left Side Door Motor/Motor Operation)

Front Door:

- (a) Connect the positive (+) lead from the battery to terminal 3 and the negative (—) lead to terminal 1, check that the motor turns clockwise.
- (b) Reverse the polarity, check that the motor turns counterclockwise.

If operation is not as specified, replace the motor.

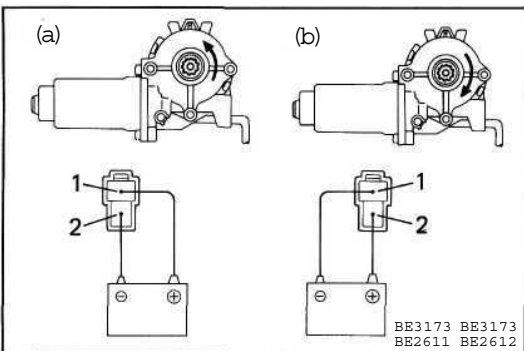

Rear Door:

- (a) Connect the positive (+) lead from the battery to terminal 1 and the negative (—) lead to terminal 2, check that the motor turns counterclockwise.
- (b) Reverse the polarity, check that the motor turns clockwise.

If operation is not as specified, replace the motor.

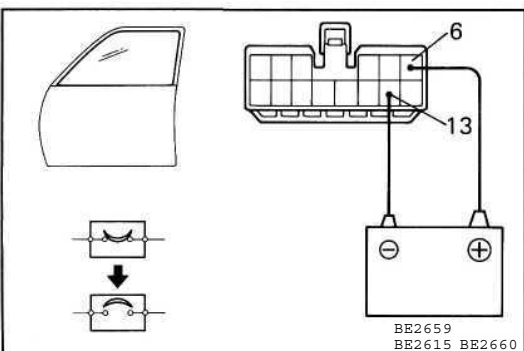

(Left Side Door Motor/Circuit Breaker Operation)

Driver's Door:

- (a) Disconnect the connector from the master switch.
- (b) Connect the positive (+) lead from the battery to terminal 6 and the negative (—) lead to terminal 13 on the wire harness side connector and raise the window to full closed position.
- (c) Continue to apply voltage, check that there is a circuit breaker operation noise within approximately 4 to 40 seconds.

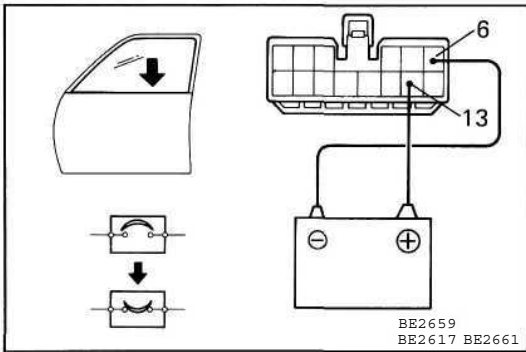

- (d) Reverse the polarity, check that the window begins to descend within approximately 60 seconds. If operation is not as specified, replace the motor.

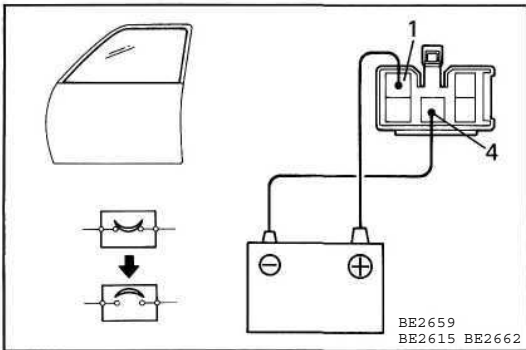

Passenger's Door:

- (a) Disconnect the connector from the power window switch.
- (b) Connect the positive (+) lead from the battery to terminal 1 and the negative (—) lead to terminal 4 on the wire harness side connector, and raise the window to full closed position.
- (c) Continue to apply voltage, check that there is a circuit breaker operation noise within approximately 4 to 40 seconds.

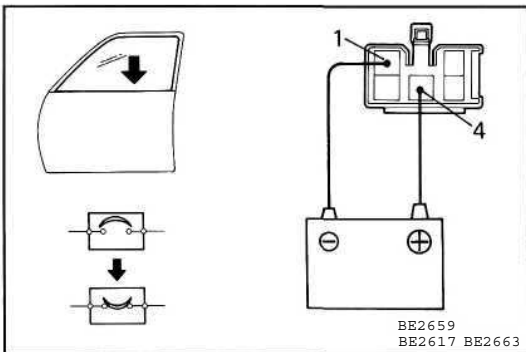

- (d) Reverse the polarity, check that the window begins to descend within approximately 60 seconds. If operation is not as specified, replace the motor.

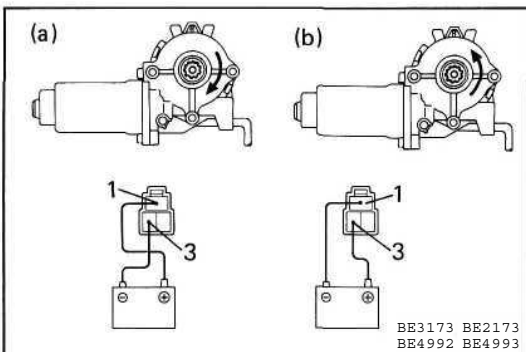

(Right Side Door Motor/Motor Operation)

Front Door:

- (a) Connect the positive (+) lead from the battery to terminal 1 and the negative (—) lead to terminal 3, check that the motor turns clockwise.
 - (b) Reverse the polarity, check that the motor turns counterclockwise.
- If operation is not as specified, replace the motor.

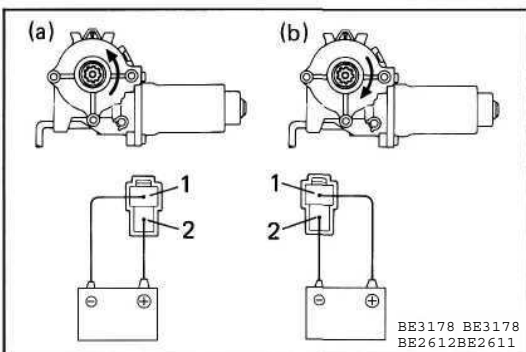

Rear Door:

- (a) Connect the positive (+) lead from the battery to terminal 2 and the negative (—) lead to terminal 1, check that the motor turns counterclockwise.
 - (b) Reverse the polarity, check that the motor turns clockwise.
- If operation is not as specified, replace the motor.

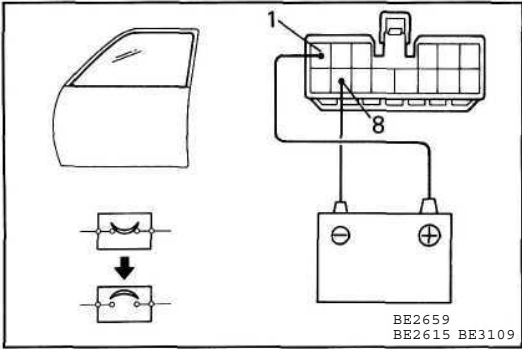

(Right Side Door Motor/Circuit Breaker Operation)

Driver's Door:

- (a) Disconnect the connector from the master switch.
- (b) Connect the positive (+) lead from the battery to terminal 1 and the negative (-) lead to terminal 8 on the wire harness side connector, and raise the window to full closed position.
- (c) Continue to apply voltage, check that there is a circuit breaker operation noise within approximately 4 to 40 seconds.
- (d) Reverse the polarity, check that the window begins to descend within approximately 60 seconds.

If operation is not as specified, replace the motor.

Passenger's Door:

See Left Side Door Motor on page BE-80.

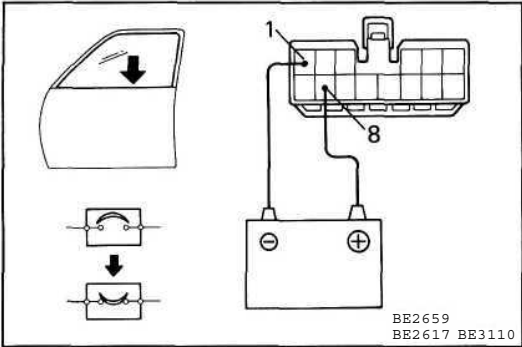

3. INSPECT POWER MAIN RELAY

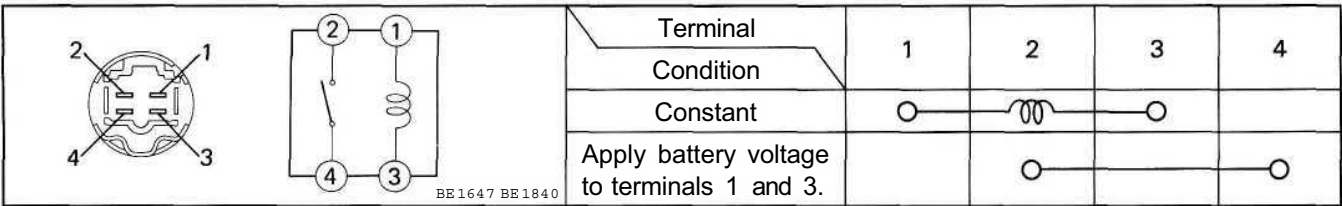

If continuity is not as specified, replace the relay.

POWER DOOR LOCK CONTROL SYSTEM

Parts Location

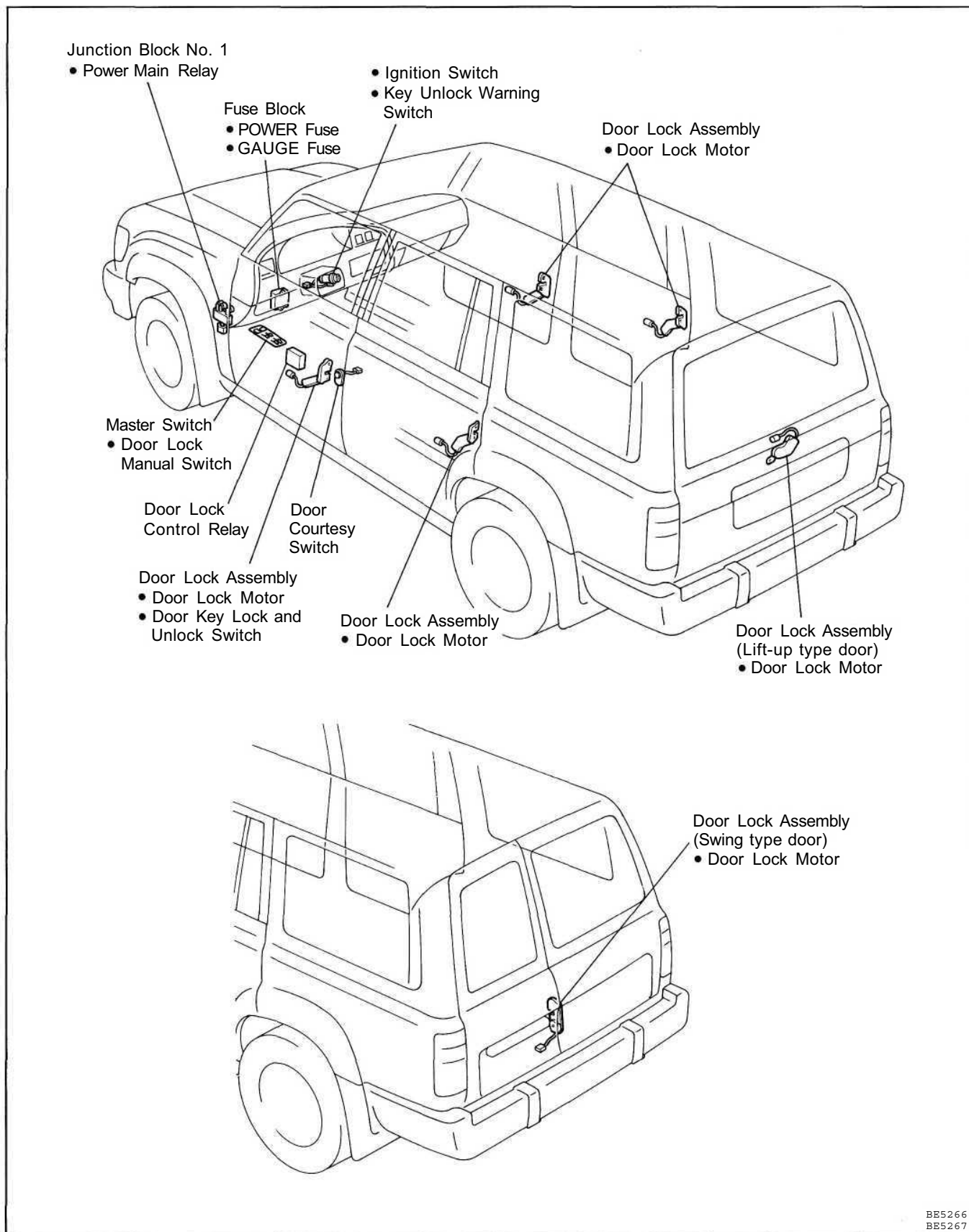

Wiring and Connector Diagrams

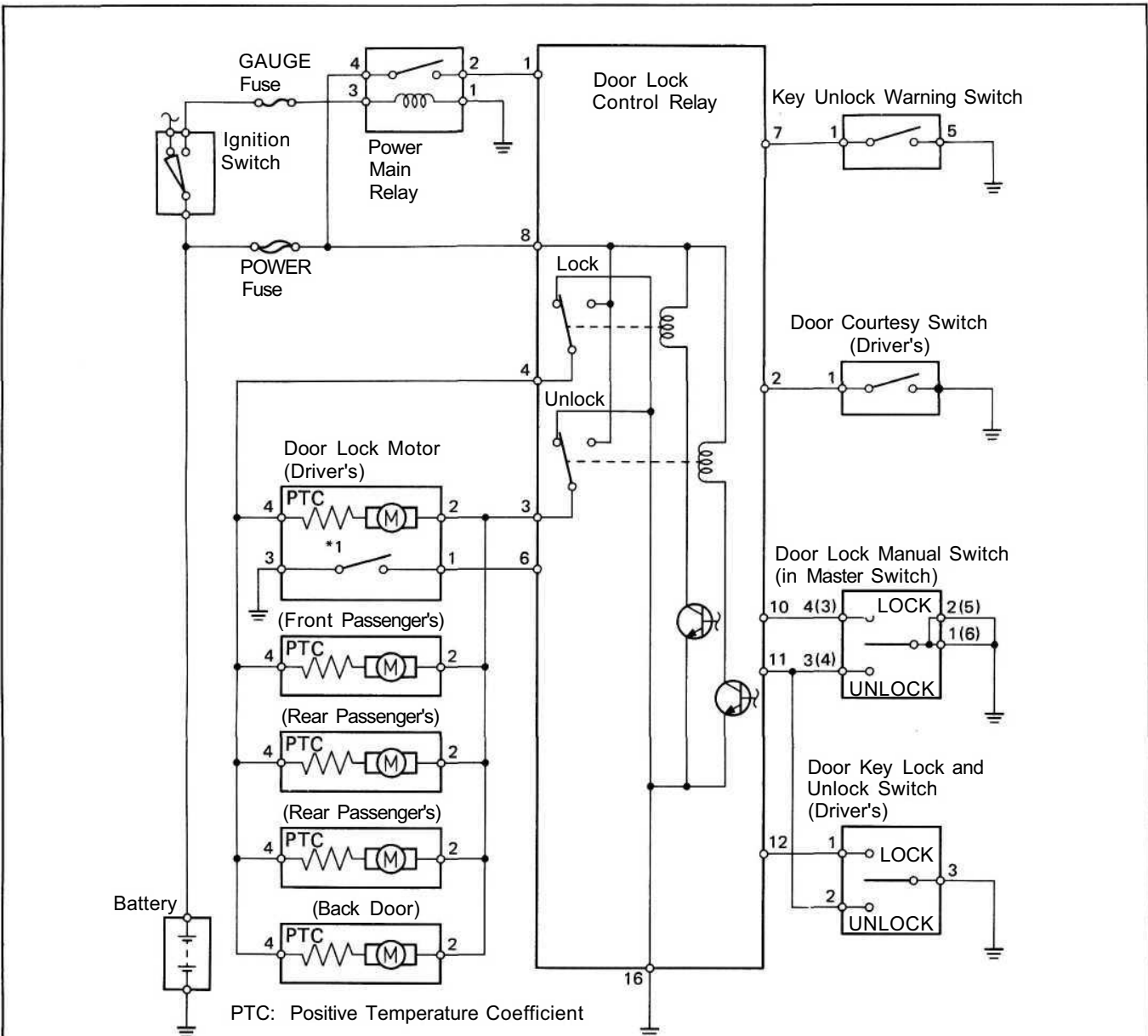

PTC: Positive Temperature Coefficient

Door Key Lock and Unlock Switch



Key Unlock Warning Switch

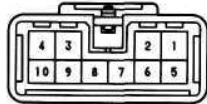

Door Courtesy Switch



Door Lock Manual Switch (in Master Switch)

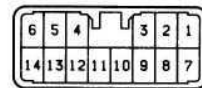

Door Lock Motor

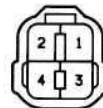

Door Lock Control Relay

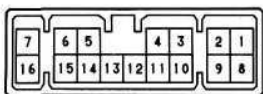

Power Main Relay

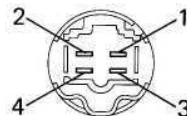

The POWER SOURCE CIRCUIT has been simplified. For full details, see pages BE-10, 11.

Troubleshooting

Problem	Possible cause	Remedy	Page
Power door lock do not operate	POWER fuse faulty	Check fuse	BE-4, 6
	Door lock motor faulty	Check motor	BE-86
	Door lock switch faulty	Check switch	BE-85
	Power main relay faulty	Check relay	BE-87
	Door lock control relay faulty	Check relay	BE-88
	Wiring or ground faulty	Repair as necessary	
Fault in key confine prevention operation	Door lock control relay faulty	Check relay	BE-88
	Key unlock warning switch faulty	Check switch	BE-85
	Door courtesy switch faulty	Check switch	BE-85
	Wiring or ground faulty	Repair as necessary	

Parts Inspection

1. INSPECT SWITCHES

(Master Switch: Driver's Door Lock Manual Switch/Continuity)

	Terminal	LHD	1	2	3	4
	Switch position	RHD	6	5	4	3
	LOCK		○	○	○	○
	OFF		○	○		
	UNLOCK		○	○	○	

If continuity is not as specified, replace the switch.

(Door Key Lock and Unlock Switch/Continuity)

	Terminal	1	2	3
	Switch position			
	LOCK	○	○	○
	OFF			
	UNLOCK		○	○

HINT: Door key lock and unlock switch is built into the front door lock assembly.

If continuity is not as specified, replace the switch.

(Key Unlock Warning Switch/Continuity)

	Terminal	1	5
	Switch position		
	OFF (Ignition key removed)		
	ON (Ignition key set)	○	○

If continuity is not as specified, replace the switch.

(Door Courtesy Switch/Continuity)

See step 2 of Open Door Warning System on page BE-64.

2. INSPECT DOOR LOCK MOTOR (Motor Operation)

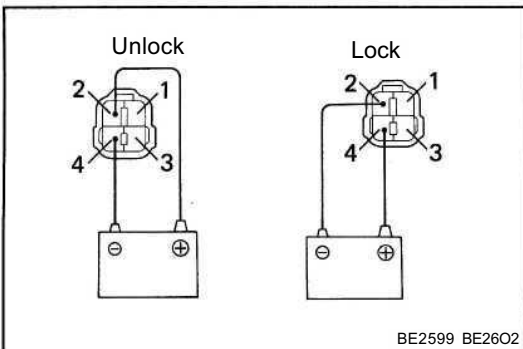
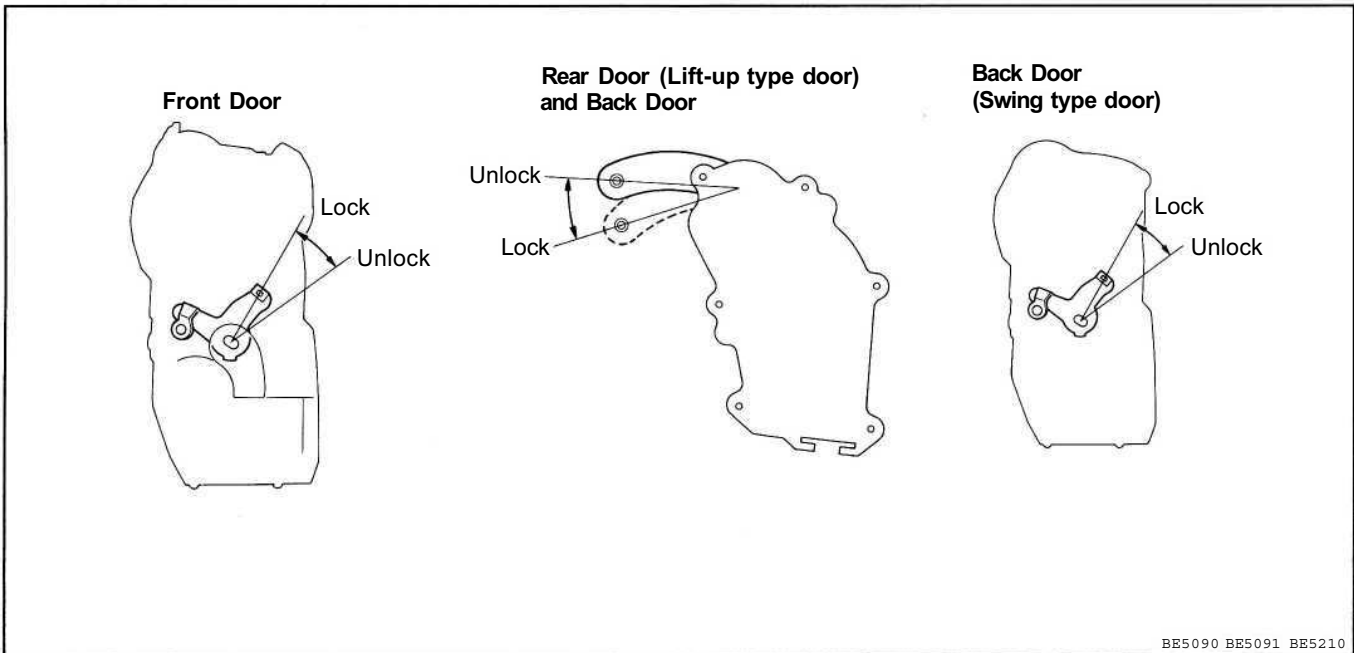

- Connect the positive (+) lead from the battery to terminal 2 and the negative (-) lead to terminal 4, check that the door lock link moves to UNLOCK position.
- Remove the polarity, check that the door lock link move to LOCK position.

If operation is not as specified, replace the door lock assembly.

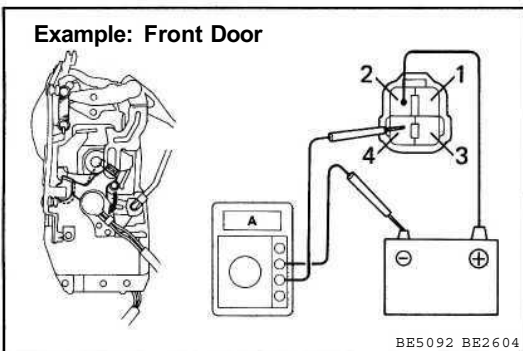

(PTC Thermistor Operation)

Inspection using an ammeter.

- Connect the positive (+) lead from the battery to terminal 2.
- Connect the positive (+) lead from the ammeter to terminal 4 and the negative (-) lead to battery negative (-) terminal, check that the current changes from approximately 3.2 ampere to less than 0.5 ampere with 20 to 70 seconds.

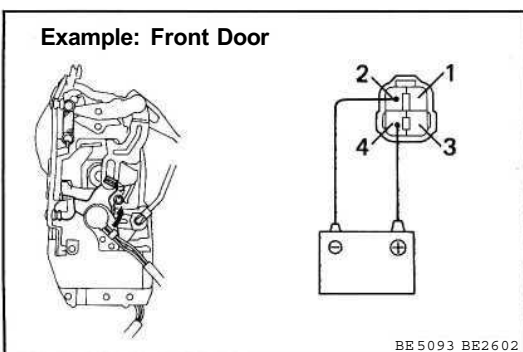

- Disconnect the leads from terminals.
- Approximately 60 seconds later, connect the positive (+) lead from the battery to terminal 4 and the negative (-) lead to terminal 2 check that the door lock moves to LOCK position.

If operation is not as specified, replace the door lock assembly.

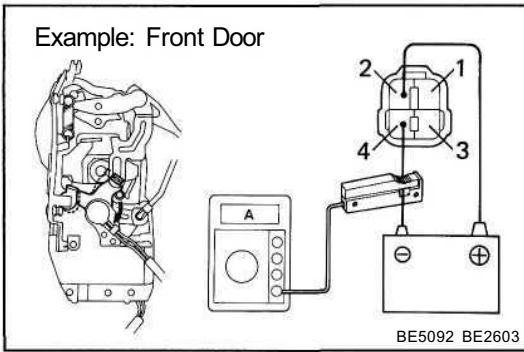

Inspection using an ammeter with a current-measuring probe.

- (a) Connect the positive (+) lead from the battery to terminal 2 and the negative (—) lead to terminal 4.
- (b) Attach a current-measuring probe to either the positive (+) lead or the negative (—) lead, check that the current changes from approximately 3.2 ampere to less than 0.5 ampere within 20 to 70 seconds.

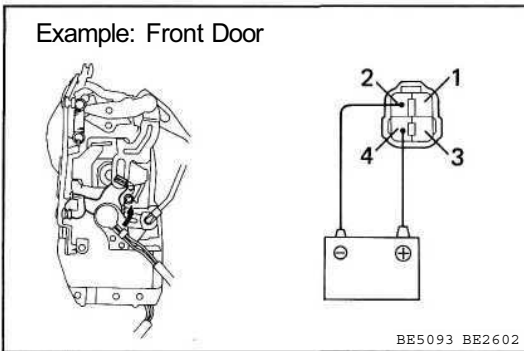

- (c) Disconnect the leads from terminals.
- (d) Approximately 60 seconds later, reverse the polarity, check that the door lock moves to LOCK position.

If operation is not as specified, replace the door lock assembly.

HINT: Perform inspection of PTC thermistor operation of other door lock motors the same way as for the front door.

(Door Lock Unlock Switch/Continuity)

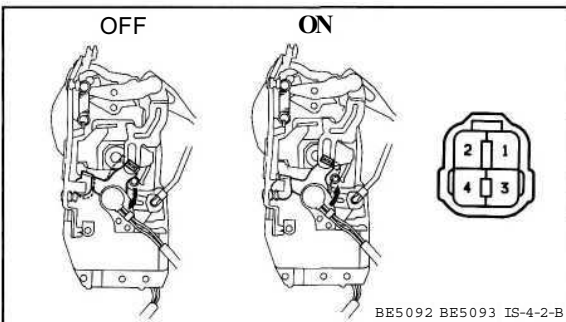

Terminal	1	3
Switch position	1	3
OFF (Door lock set to LOCK)		
ON (Door lock set to UNLOCK)	○ — ○	○ — ○

If continuity is not as specified, replace the door lock assembly.

3. INSPECT POWER MAIN RELAY

See inspect power main relay on page BE-82.

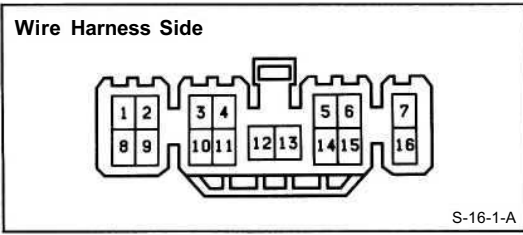

4. INSPECT DOOR LOCK CONTROL RELAY (Relay Circuit)

Disconnect the connector from the relay and inspect the connector on the wire harness side as shown in the chart.

Check for	Tester connection	Condition	Specified value	
Continuity	2—Ground	Driver's door courtesy switch position	OFF (Door closed)	No continuity
			ON (Door opened)	Continuity
	6—Ground	Driver's door lock and unlock switch position	OFF (Door locked)	No continuity
			ON (Door unlocked)	Continuity
	7—Ground	Key unlock warning switch position	OFF (Ignition key removed)	No continuity
			ON (Ignition key set)	Continuity
	10—Ground	Door lock manual switch position	OFF or UNLOCK	No continuity
			LOCK	Continuity
	11—Ground	Door lock manual switch position	OFF or LOCK	No continuity
			UNLOCK	Continuity
12—Ground	Door key lock and unlock switch position	OFF or UNLOCK (Door key free or turned to UNLOCK)	No continuity	
		LOCK (Door key turned to LOCK)	Continuity	
11—Ground	Door key lock and unlock switch position	OFF or LOCK (Door key free or turned to LOCK)	No continuity	
		UNLOCK (Door key turned to UNLOCK)	Continuity	
	16—Ground	Constant	Continuity	
Voltage	1—Ground	Ignition switch position	LOCK	No voltage
			ACC or ON	Battery voltage
		8—Ground	Constant	Battery voltage

If circuit is as specified, inspect the door lock signal.

If the circuit is not as specified, refer to BE-84 wiring diagram and inspect the circuits connected to other parts.

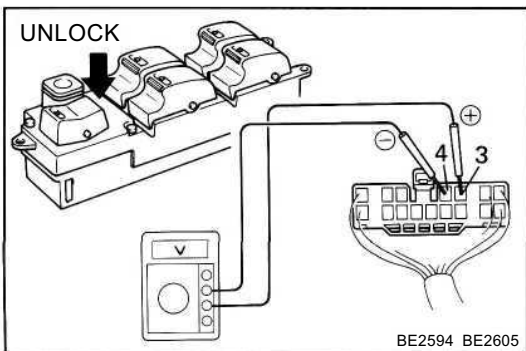

(Door Lock Signal)

HINT: When the relay circuit is as specified, inspect the door lock signal.

- (a) Connect the connector to the relay.
- (b) Connect the positive (+) lead from the voltmeter to terminal 3 and the negative (—) lead to terminal 4.
- (c) Set the door lock manual switch to UNLOCK, check that the voltage rises from 0 volts to battery voltage for approximately 0.2 seconds.

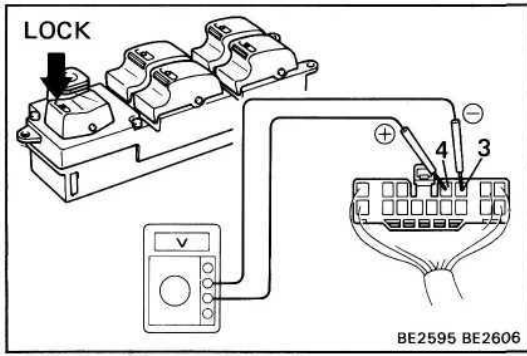

- (d) Reverse the polarity of the voltmeter leads.
- (e) Set the door lock manual switch to LOCK, check that the voltage rises from 0 volts to battery voltage for approximately 0.2 seconds.

If operation is not as specified, replace the relay.

SLIDING ROOF SYSTEM Parts Location

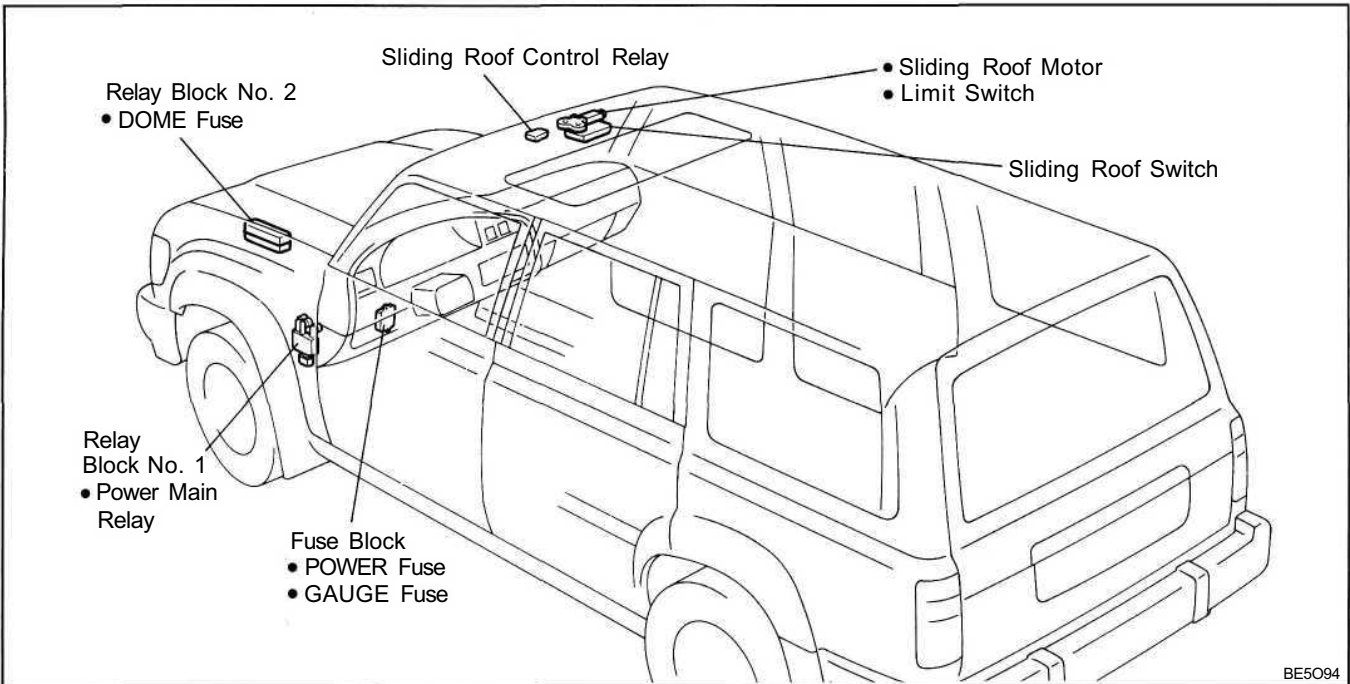

BE5094

Wiring and Connector Diagrams

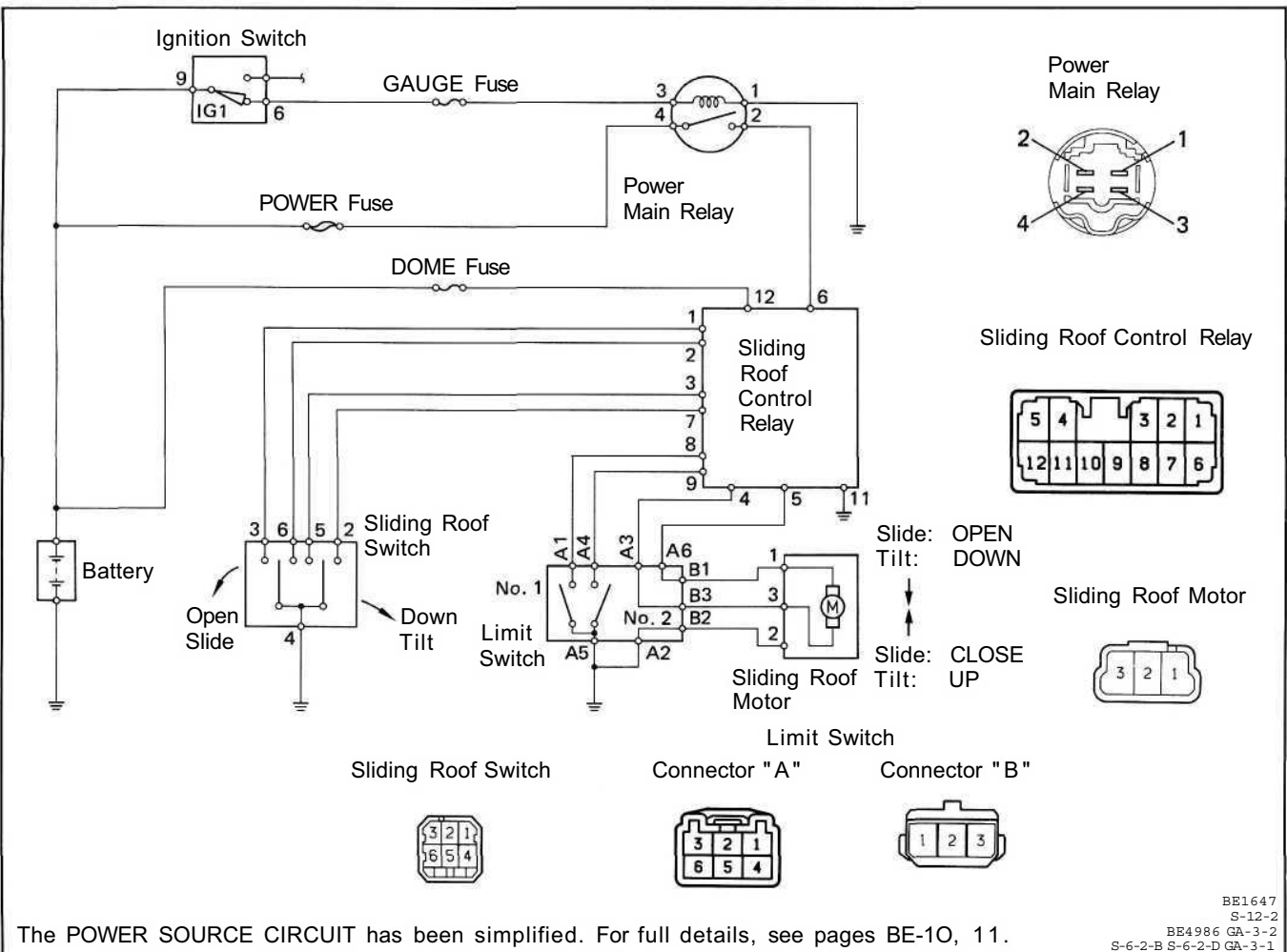

The POWER SOURCE CIRCUIT has been simplified. For full details, see pages BE-10, 11.

BE1647
S-12-2
BE4986 GA-3-2
S-6-2-B S-6-2-D GA-3-1

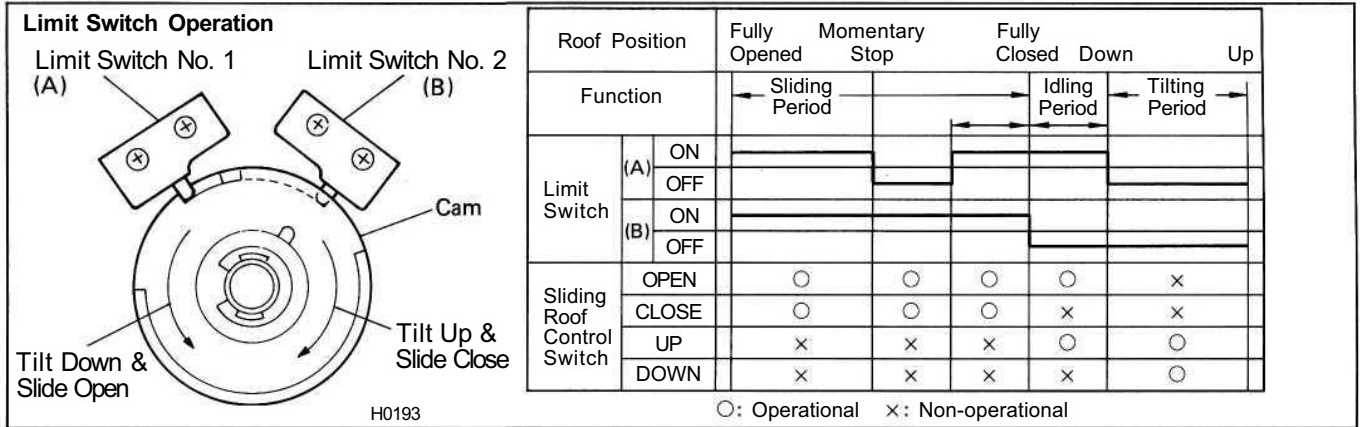

System Description

Standby Operation

- Current flows from the DOME fuse to terminal 12 of the Sliding Roof Relay (hereafter called relay)
- When the ignition switch is on, the current flows from the POWER fuse to terminal 6 of the relay.

Operation

1. OPEN operation

When the switch on the "OPEN" side of the control switch is pushed, continuity is produced between terminal 1 of the relay and body ground. Then, the relay operates, the current flows through terminal 6 of the relay → terminal 5 → terminal 1 of the sliding roof motor → terminal 3 → terminal 4 of the relay → terminal 11 → the body ground, and the motor starts to run in order to open the sliding roof.

2. CLOSE operation

When the switch on the "CLOSE" side of the control switch is pushed, continuity is produced between terminal 2 of the relay and body ground. Then, the relay operates, the current flows through terminal 6 of the relay → terminal 4 → terminal 3 of the sliding roof motor → terminal 1 → terminal 5 of the relay → terminal 11 → the body ground, and the motor starts to run in order to close the sliding roof.

Momentary Stop

When the sliding roof reaches about 100 mm (3.94 in.) short of the fully closed position, limit switch A is turned from ON to OFF, so there is no continuity between terminal 8 of the relay and the body ground. As a result, because the relay ceases to operate, and the sliding roof stops at that position. Release the control switch, then press the "CLOSE" side of the control switch again. Then the sliding roof moves to fully closed position.

3. Tilt up operation (Fully close position)

When the switch on the "UP" side of the control switch is pushed, continuity is produced between terminal 3 of the relay and body ground. Then, the relay operates, the current flows through terminal 6 of the relay → terminal 4 → terminal 3 of the sliding roof motor → terminal 1 → terminal 5 of the relay → terminal 11 → the body ground, and the motor starts to run in order to tilt up sliding roof.

4. Tilt Down operation (Fully close position)

When the switch on the "DOWN" side of the control switch is pushed, continuity is produced between terminal 7 of the relay and body ground. Then the relay operates, the current flows through terminal 6 of the relay → terminal 5 → terminal 1 of the sliding roof motor → terminal 3 → terminal 4 of the relay → terminal 11 → the body ground, and the motor starts to run in order to tilt down the sliding roof.

5. Warning buzzer operation

When the ignition switch is turned to LOCK position while the sliding roof is still in "Tilt up" position, a buzzer sounds to warn the driver that the sliding roof is in "Tilt up" position.

Troubleshooting

Problem	Possible cause	Remedy	Page
Sliding roof does not operate	GAUGE fuse blown	Replace fuse and check for short	BE-4, 6
	POWER fuse blown	Replace fuse and check for short	BE-4, 6
	Power main relay faulty	Check relay	BE-94
	Control switch faulty	Check switch	BE-92
	Limit switch faulty	Check switch	BE-92
	Sliding roof motor faulty	Check motor	BE-92
	Sliding roof control relay faulty	Check relay	BE-93
	Wiring faulty	Repair as necessary	

Parts Inspection

1. INSPECT SWITCHES (Control Switch/Continuity)

Terminal Switch position	2	3	4	5	6
	SLIDE		○—○		
OFF					
CLOSE			○—○		○
TILT	○—○				
DOWN			○—○		
OFF					
UP			○—○		

BE4999 S-6-2-B

If continuity is not as specified, replace the switch.

(Limit Switch/Continuity)

Terminal Switch position	1	4	5
	Limit switch No.1		
OFF (SW pin released)			
ON (SW pin pushed in)	○—○		○
Limit switch No.2			
OFF (SW pin released)			
ON (SW pin pushed in)		○—○	○

BE2859 S-6-2-D

If continuity is not as specified, replace the switch.

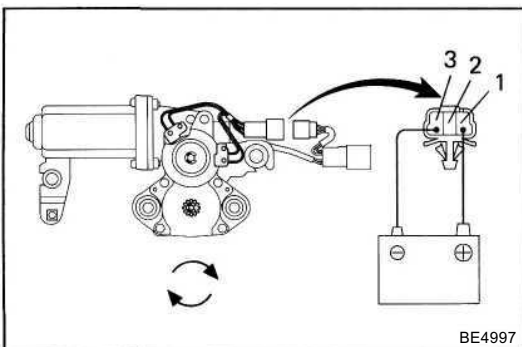

2. INSPECT SLIDING ROOF MOTOR (Motor Operation)

- Connect the positive (+) lead from the battery to terminal 1 and the negative (—) lead to terminal 3, check that the motor turns to clockwise.
- Reverse the polarity, check that the motor turns to counter clockwise.

If operation is not as specified, replace the motor.

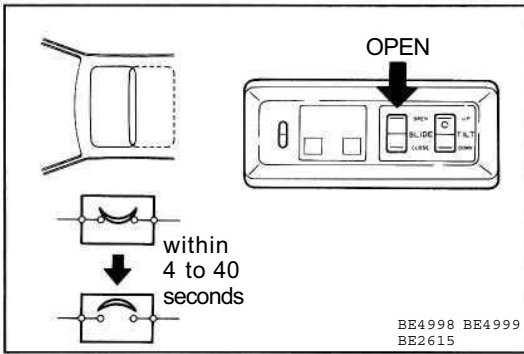

(Circuit Breaker Operation)

(a) With the sliding roof in the fully opened position, hold the control switch in "OPEN" position and check that there is a circuit breaker operation noise within 4 to 40 seconds.

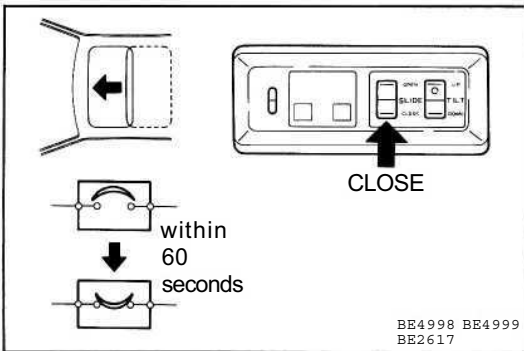

(b) With the sliding roof in fully opened position, hold the control switch in "CLOSE" position and check that the sliding roof begins to close within 60 seconds. If operation is not as specified, replace the motor.

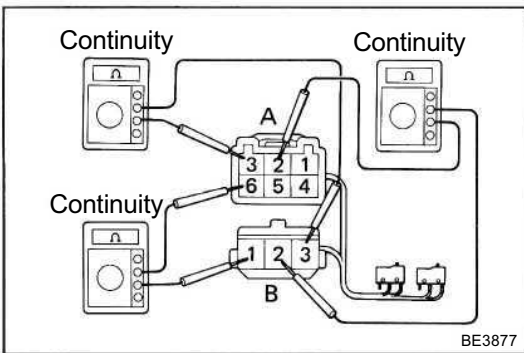

(Motor Wire Circuit)

- (a) Check that there is continuity between terminals A2 and B2.
- (b) Check that there is continuity between terminals A3 and B3.
- (c) Check that there is continuity between terminals A6 and B1.

If continuity is not as specified, replace the switch.

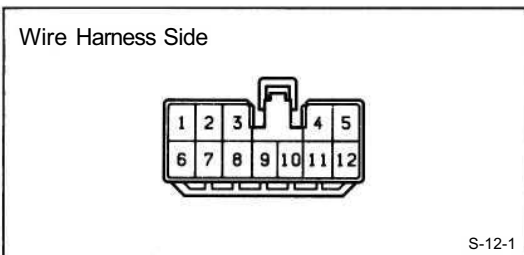

3. INSPECT SLIDING ROOF CONTROL RELAY (Relay Circuit)

Disconnect the connector from the relay and inspect the connector on the wire harness side as shown in the chart.

Check for	Tester connection	Condition	Specified value
Continuity	1 — Ground	Sliding roof control switch position (SLIDE) OFF or CLOSE	No continuity
		OPEN	Continuity
	2 - Ground	Sliding roof control switch position (SLIDE) OFF or OPEN	No continuity
		CLOSE	Continuity
3 — Ground	Sliding roof control switch position (TILT)	OFF or DOWN	No continuity
		UP	Continuity
4 - 5	Constant		*Continuity

*: There is resistance because this circuit include the motor.

Check for	Tester connection		Condition	Specified value
Continuity	7 — Ground	Sliding roof control switch position (TILT)	OFF or UP	No continuity
			DOWN	Continuity
	8 — Ground	Limit switch No.1 (A) position	OFF (Sliding roof tilt up or approx. 100 mm (3.94 in.) opened)	No continuity
			ON (Except for conditions mentioned above)	Continuity
	9 — Ground	Limit switch No.2 (B) position	OFF (Sliding roof tilt-up)	Continuity
ON (Sliding roof opened)			No continuity	
11 — Ground	Constant		Continuity	
Voltage	6 — Ground	Ignition switch position	LOCK or ACC	No voltage
			ON	Battery voltage
	12 — Ground	Constant		Battery voltage

If circuit is as specified, replace the relay.

4. INSPECT POWER MAIN RELAY

See power main relay on page BE-82.

POWER MIRROR CONTROL SYSTEM

Parts Location

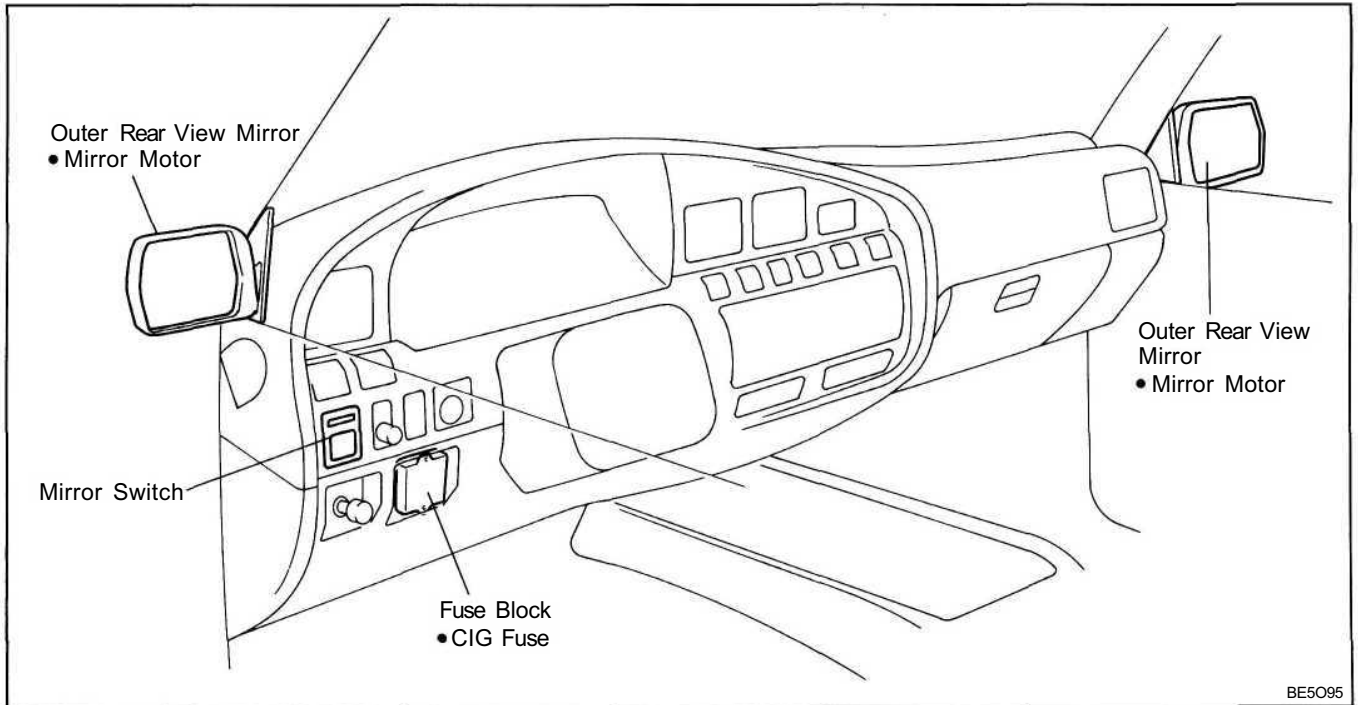

BE5095

Wiring and Connector Diagrams

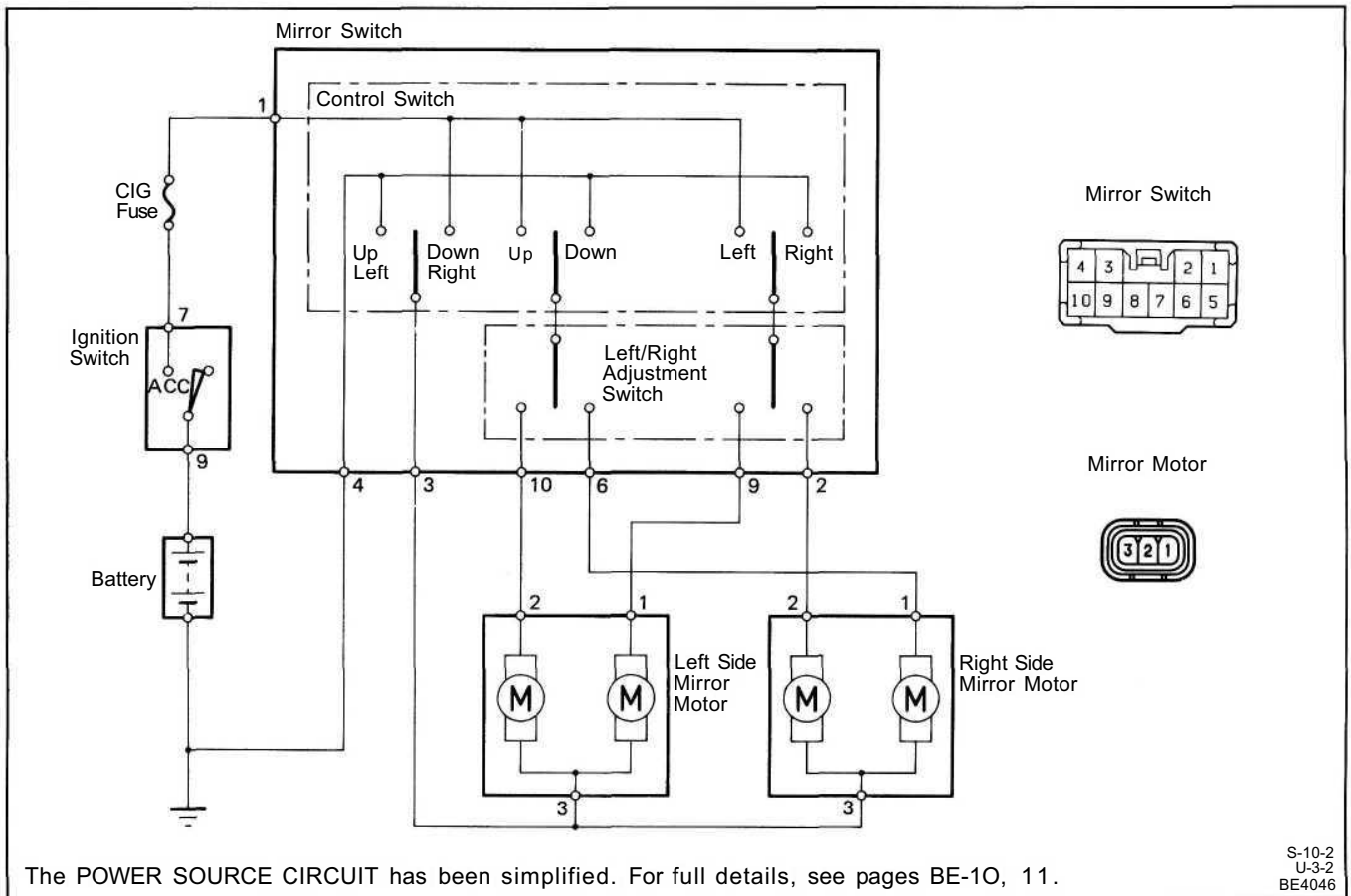

The POWER SOURCE CIRCUIT has been simplified. For full details, see pages BE-10, 11.

S-10-2
U-3-2
BE4046

Troubleshooting

Problem	Possible cause	Remedy	Page
Remote control mirror system does not operate	CIG fuse faulty Mirror switch faulty Mirror motor faulty Wiring or ground fault	Replace fuse and check for short Check switch Check motor Repair as necessary	BE-4, 6 BE-96 BE-96

Parts Inspection

1. INSPECT MIRROR SWITCH (Continuity)

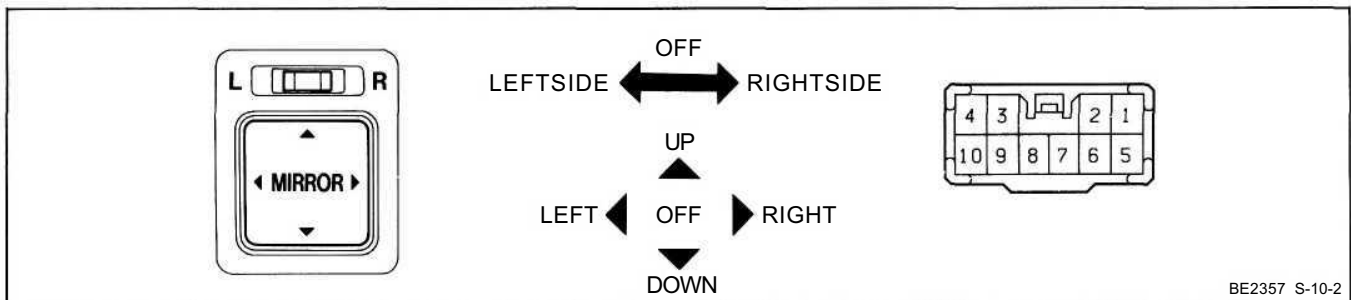

BE2357 S-10-2

Left/Right adjustment switch position	LEFT SIDE					OFF			RIGHT SIDE				
Terminal	1	3	4	9	10	1	3	4	1	2	3	4	6
Control switch position													
OFF													
UP	○	○	○	○	○				○	○	○	○	○
DOWN	○	○	○	○	○	○	○		○	○	○	○	○
LEFT	○	○	○	○				○	○	○	○	○	
RIGHT	○	○	○	○		○	○		○	○	○	○	

If continuity is not as specified, replace the switch.

2. INSPECT MIRROR MOTOR

Connect the positive (+) lead from the battery to terminal in column "A" and the negative (-) lead to terminal in column "B", check that the mirror operates in column "C".

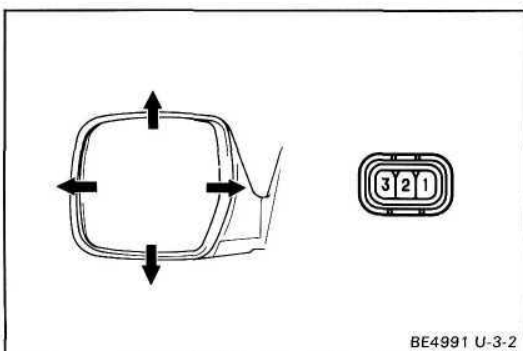

BE4991 U-3-2

A (+)	B (-)	C (Operation)
2	3	Mirror turns upward
3	2	Mirror turns downward
1	3	Mirror turns to left side
3	1	Mirror turns to right side

If operation is not as specified, replace the mirror assembly.

POWER SEAT CONTROL SYSTEM Parts Location

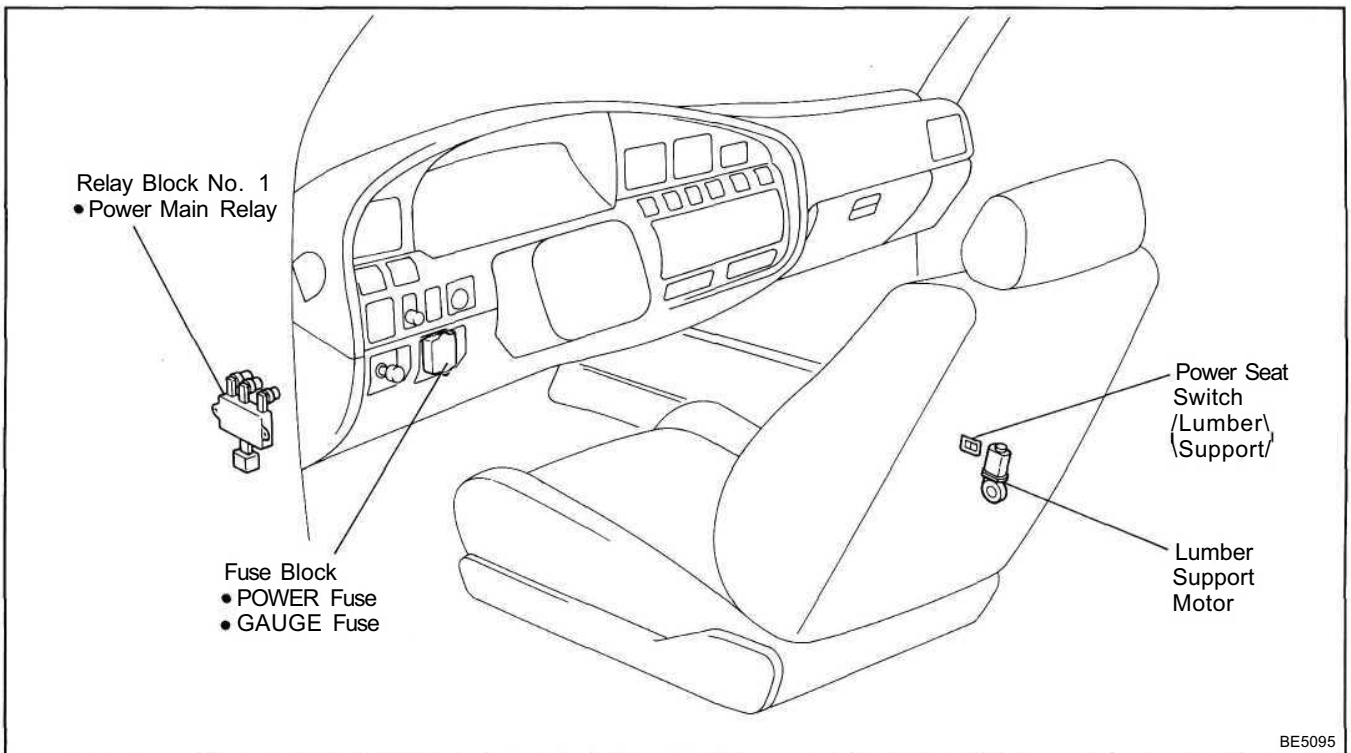

Wiring and Connector Diagrams

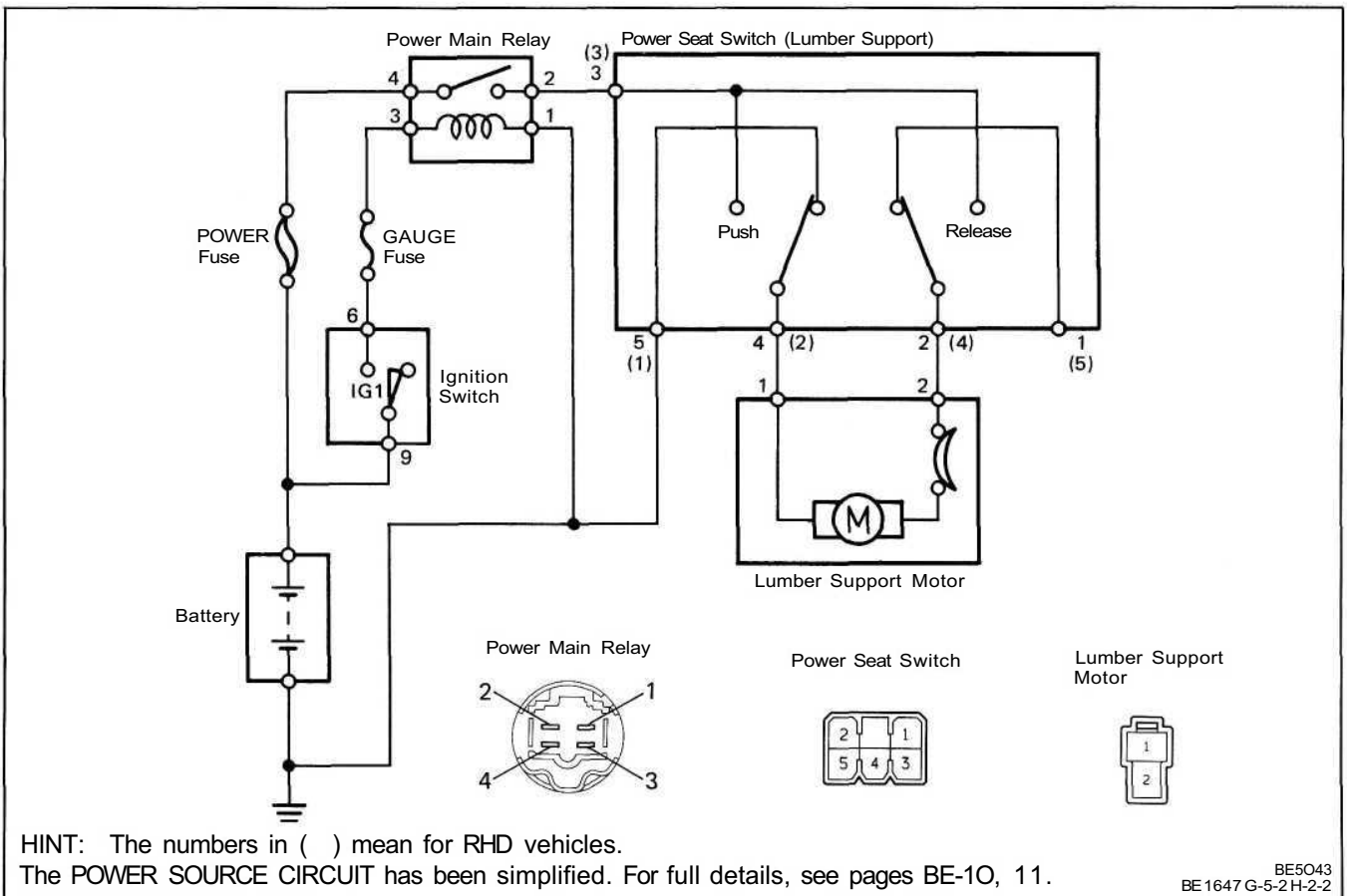

Troubleshooting

Problem	Possible cause	Remedy	Page
Power seat control system does not operate	"GAUGE" fuse faulty	Replace fuse and check for short	BE-4, 6
	"POWER" fuse faulty	Replace fuse and check for short	BE-4, 6
	Power main relay faulty	Check relay	BE-98
	Power seat switch faulty	Check switch	BE-98
	Seat motor faulty	Check motor	BE-98
	Wiring or ground faulty	Repair as necessary	

Parts Inspection

1. INSPECT POWER SEAT SWITCH (Continuity)

RHD		Terminal	LHD	1	2	3	4	5
			RHD	5	4	3	2	1
LHD		Lumber Support Switch	PUSH					
			OFF					
			RELEASE					

BE5044
BE5045 G-5-2

If continuity is not as specified, replace the switch.

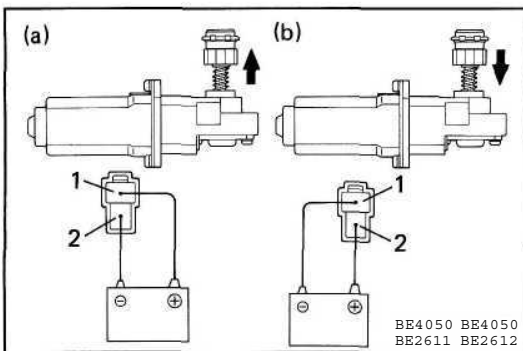

2. INSPECT POWER MAIN RELAY

See Power Main Relay on page BE-82.

3. INSPECT MOTORS (Lumber Support Motor/Motor Operation)

- Connect the positive (+) lead from the battery to terminal 1 and the negative (-) lead to terminal 2, check that the motor moves upward.
- Reverse the polarity, check that the motor moves downward.

If operation is not as specified, replace the motor.

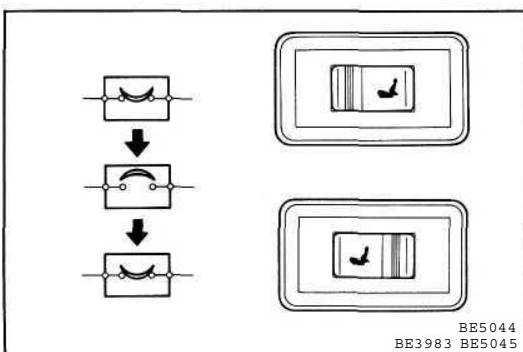

(Lumber Support Motor/Circuit Breaker Operation)

- Set the power seat switch to push operation and move the lumber support to the most forward position.
- Continue push operation and check that there is a circuit breaker operation noise within 4 to 60 seconds.
- Reverse the polarity, check that the lumber support starts to move rearward within approximately 60 seconds.

If operation is not as specified, replace the motor.

SEAT HEATER SYSTEM

Parts Location

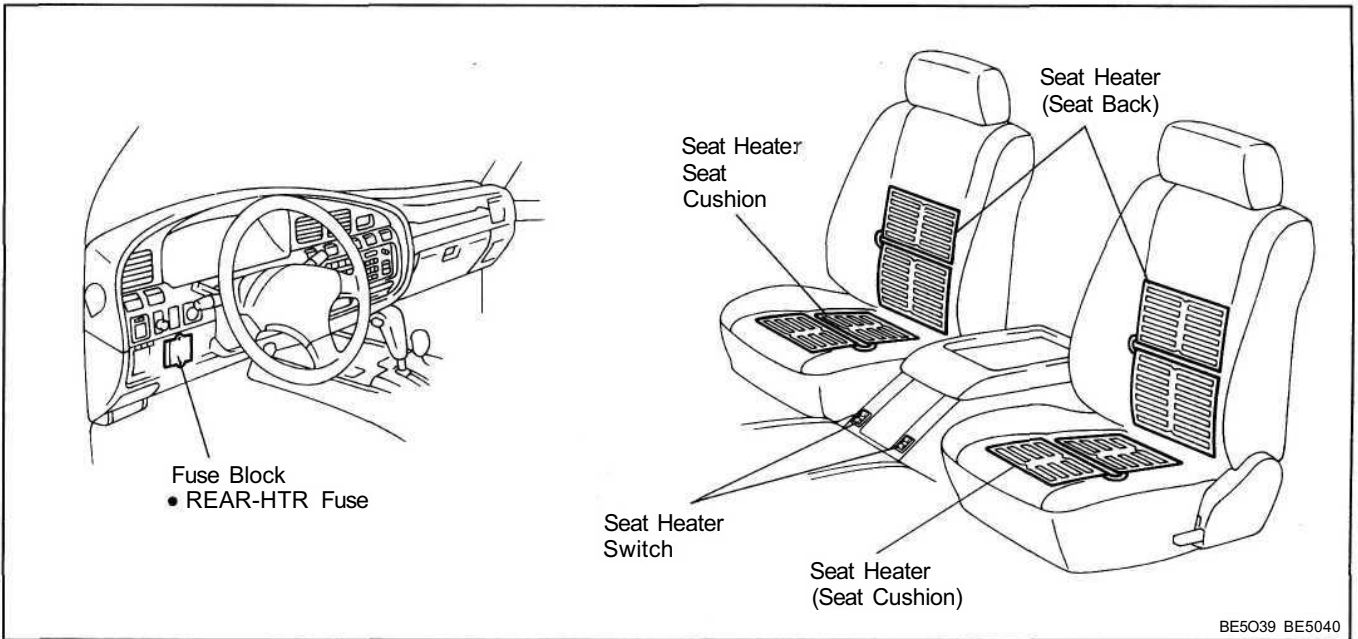

BE5039 BE5040

Wiring and Connector Diagrams

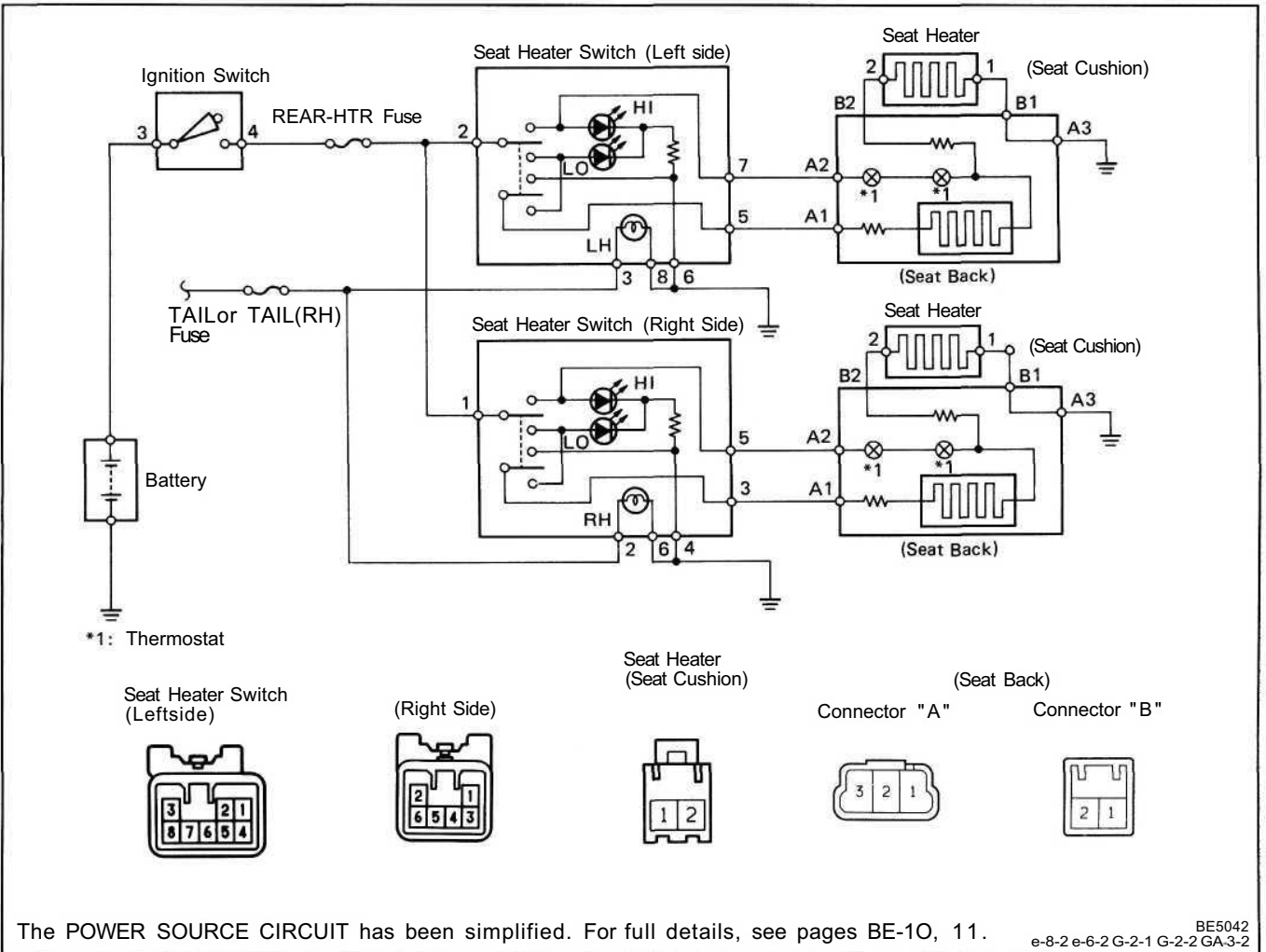

The POWER SOURCE CIRCUIT has been simplified. For full details, see pages BE-10, 11.

BE5042
e-8-2 e-6-2 G-2-1 G-2-2 GA-3-2

System Description

HINT: The number in () is for the right side.

Standby Operation

- When the Ignition Switch is on, current flows from the battery to terminal 2 (1) of the Seat Heater Switch.

Operation

"HI" Operation

When the Seat Heater Switch is set to the "HI" position, current flows through terminal 2 (1) of the Seat Heater Switch → terminal 7 (5) of the Seat Heater Switch → terminal A2 (A2) of the seat back side → the seat back, where it is divided into a parallel circuit. Then current flows through terminal B2 (B2) of the seat back → terminal 2 (2) of the seat cushion → terminal 1 (1) of the seat cushion → terminal B1 (B1) of the seat back → terminal A3 (A3) of the seat back → ground, so that the seat cushion can be warmed. At the same time, current also flows through terminal A1 (A1) of the seat back → terminal 5 (3) of the Seat Heater Switch → terminal 6 (4) of the Seat Heater Switch → ground, so that the seat back can be warmed.

When the seat surface temperature reaches over approx. 40 °C (140 °F), current is shut off by the thermostat so that the temperature cannot increase any more. When it decreases below approx. 20 °C (68 °F), the contact is made again by the thermostat so that the seat can be warmed.

"LO" Operation

When the Seat Heater Switch is set to the "LO" position, current flows in series through terminal 2 (1) of the Seat Heater Switch → terminal 5 (3) of the Seat Heater Switch → terminal A1 (A1) of the seat back → terminal B2 (B2) of the seat back → terminal 2 (2) of the seat cushion → terminal 1 (1) of the seat cushion → terminal B1 (B1) of the seat back → terminal A3 (A3) of the seat back → ground, so that the seat cushion and back can be warmed.

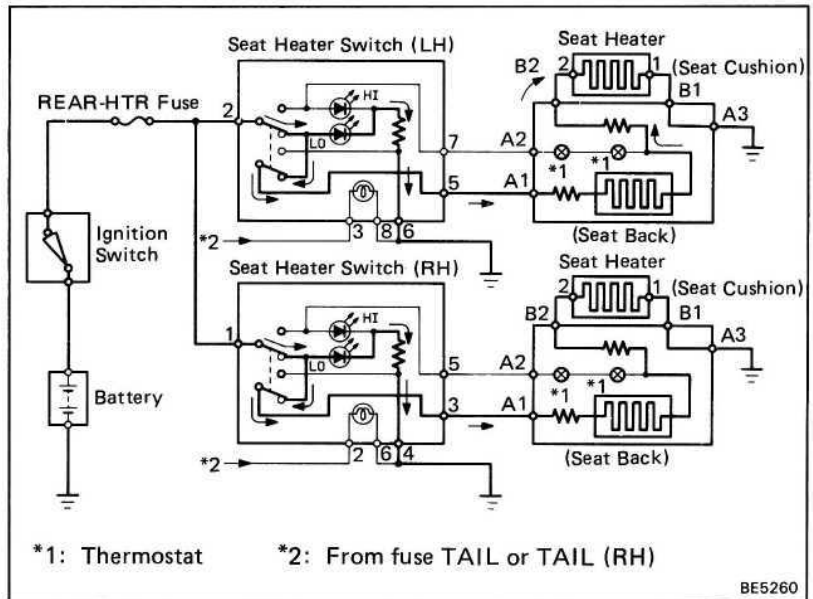
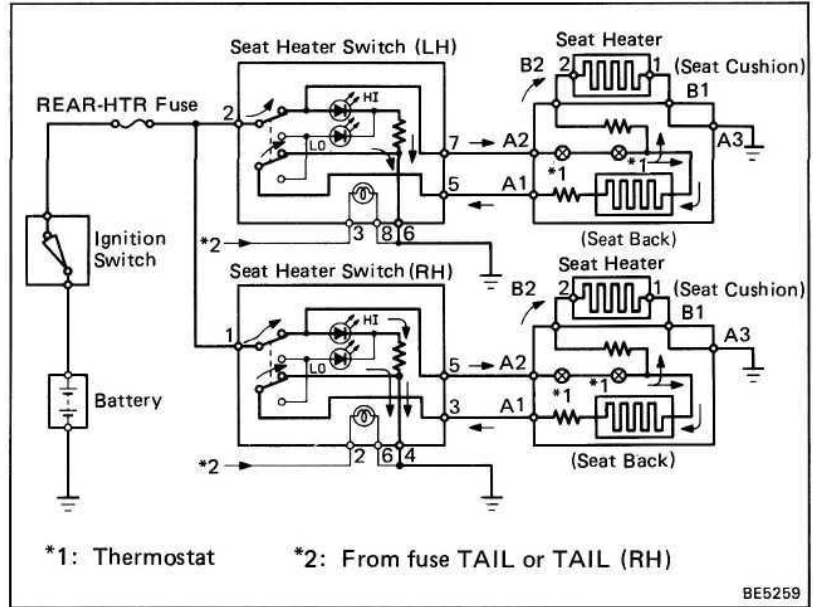

Troubleshooting

Problem	Possible cause	Remedy	Page
Seat heater do not operate	REAR-HTR fuse blown Heat wire faulty Thermostat faulty Seat heater switch faulty Wiring or ground faulty	Replace fuse and check for short Check heat wire Check thermostat Check switch Repair as necessary	BE-4, 6 BE-102 BE-102 BE-101

Parts Inspection

1. INSPECT SEAT HEATER SWITCH (Continuity)

(): Right side

Terminal Switch position	2 (1)	7 (5)	5 (3)	6 (4)	Illumination	
					3(2)	8(6)
HI	○	○	○	○	○	
OFF					○	
LO	○		○		○	

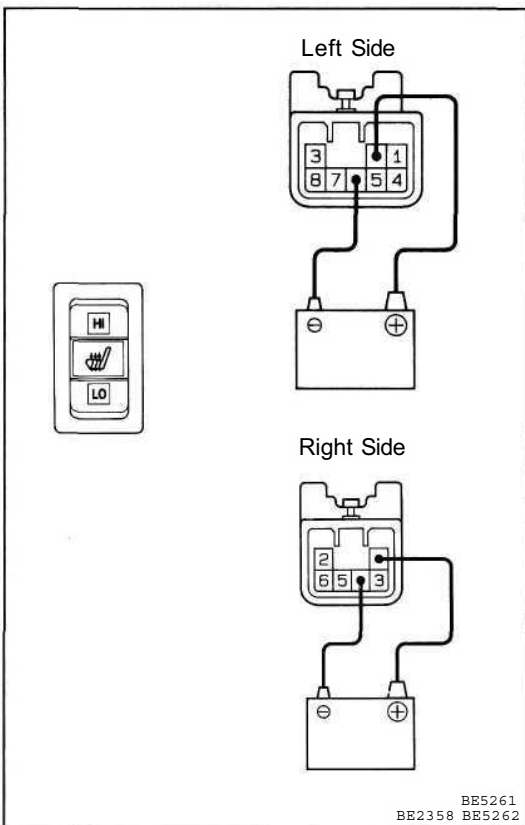

If continuity is not as specified, replace the switch.

(Indicator Light/Operation)

- (Left side)
Connect the positive (+) lead from the battery to terminal 2 and the negative (—) lead to terminal 6.
(Right side)
Connect the positive (+) lead from the battery to terminal 1 and the negative (—) lead to terminal 4.
- Push the switch to HI or LO, check that the indicator light of the pushed side lights up.

If operation is not as specified, replace the switch.

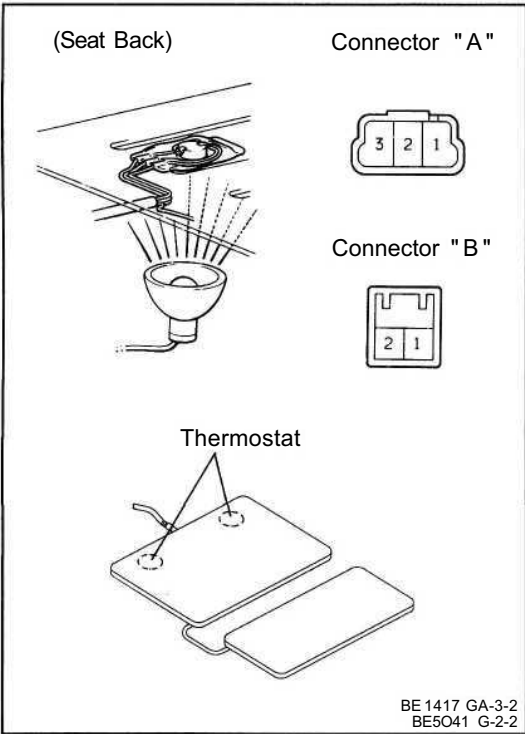

2. INSPECT SEAT HEATER
(Seat Back Side/Continuity)

Tester connection	Condition	Specified Value
A3 - B1	Constant	Continuity
A1 - B2	Constant	Continuity *1
A1 - A2	Heat the thermostat to approx. 45°C (113°F) or more	No continuity
A2 - B2	Cool the thermostat to approx. 15°C (59°F) or less	Continuity

*1: There is resistance in the circuit.

If operation is not as specified, replace the seat heater.

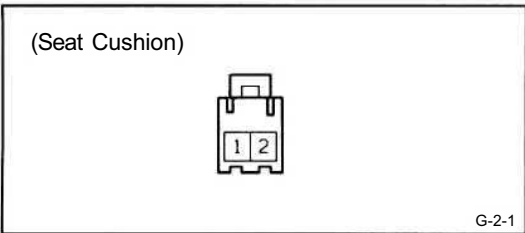

(Seat Cushion Side/Continuity)

Check that there is continuity between terminals. If continuity is not as specified, replace the seat heater.

CRUISE CONTROL SYSTEM

Parts Location

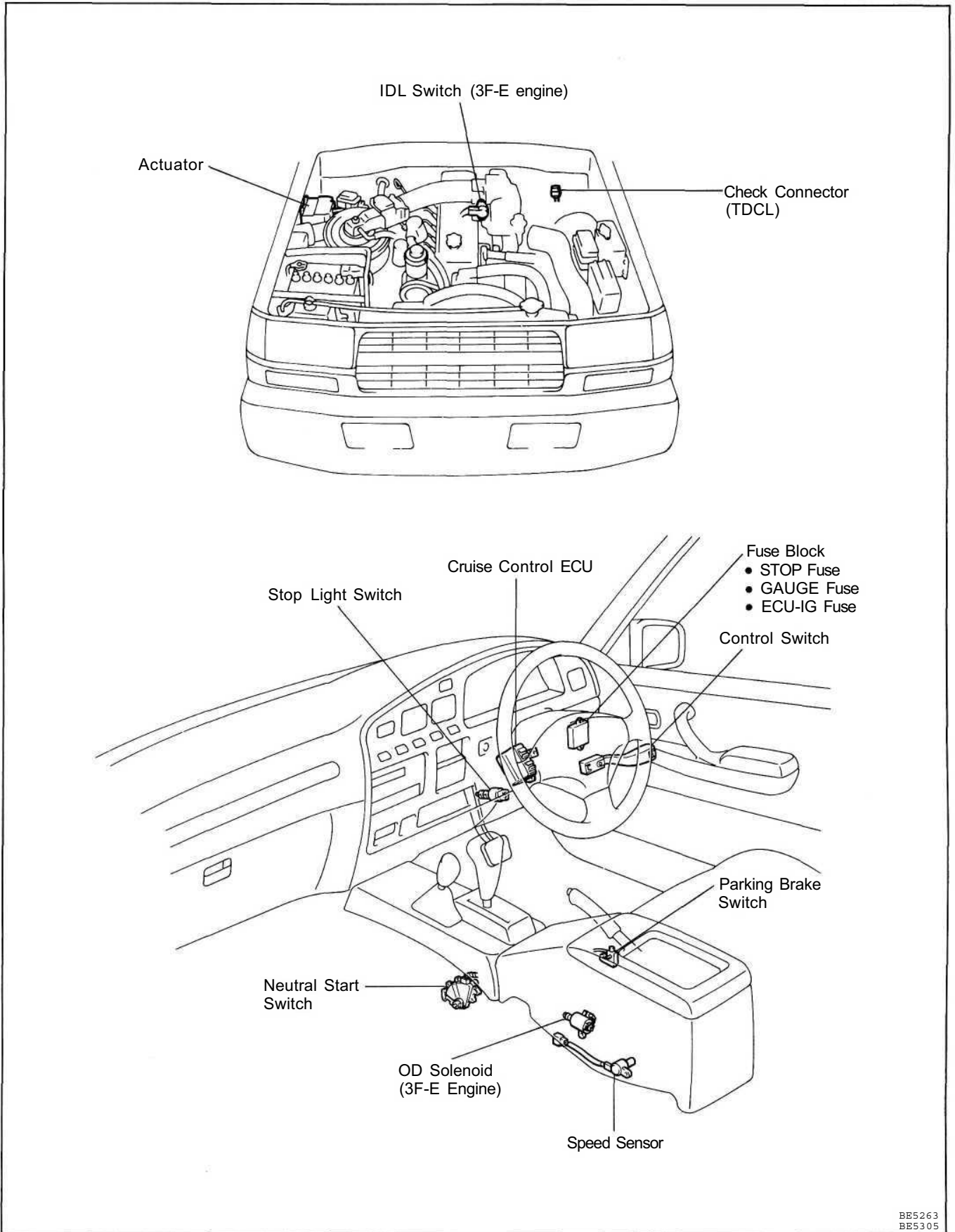

Wiring Diagram

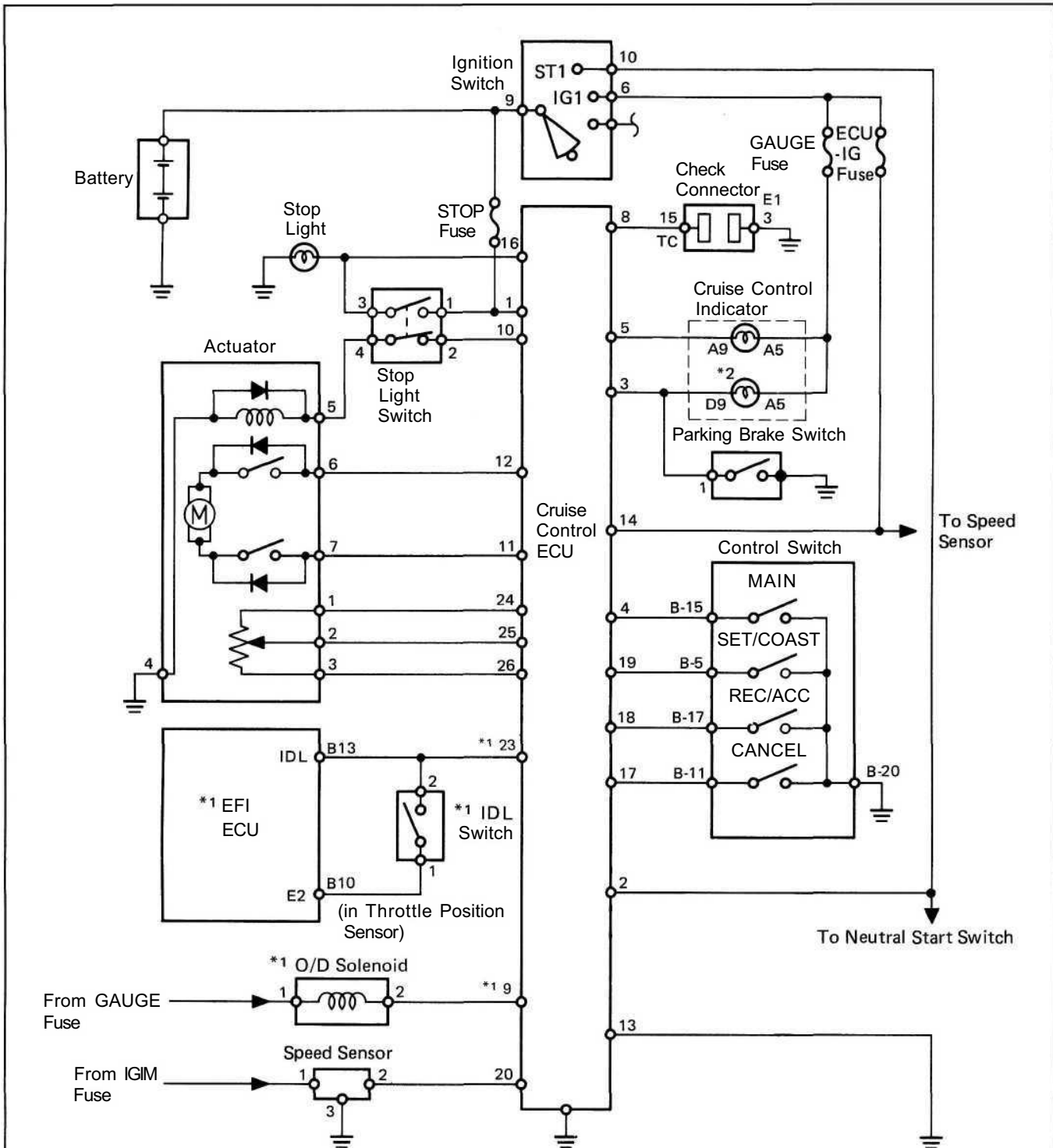

- *1: 3F-E engine
- *2: Brake Warning Light
- []: Combination Meter

The POWER SOURCE CIRCUIT has been simplified. For full details, see pages BE-10, 11.

Connector Diagrams

Cruise Control ECU

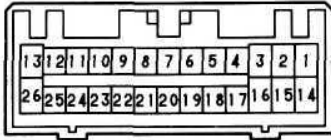

Control Switch (in Combination Switch)

Connector "A"

Connector "B"

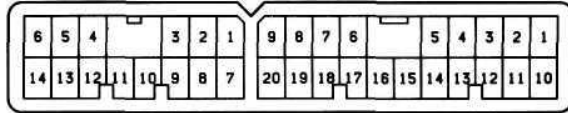

Stop Light Switch

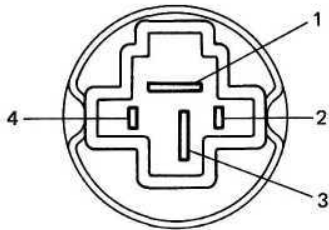

Parking Brake Switch

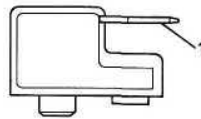

Speed Sensor



Actuator



O/D Solenoid (3F-E)



Throttle Position Sensor (3F-E)

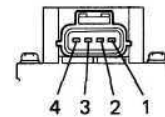

Ignition Switch

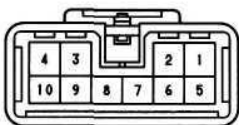

Check Connector (TDCL)

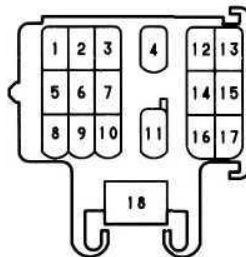

Combination Meter (Cruise Control Indicator)

Connector "A"

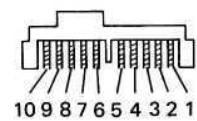

(Brake Warning)

Connector "D"

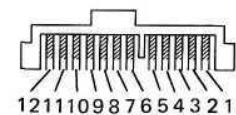

EFI ECU (3F-E)

Connector "C"

Connector "B"

Connector "A"

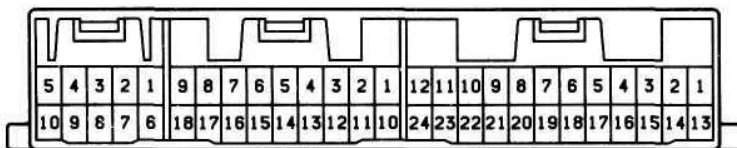

System Description

- When the ignition switch is turned ON, current flows from the battery to terminal 14 of the cruise control (CO ECU).
- Terminal 13 of the CC ECU is always grounded.

Basic Operation

HINT: For all explanations below, the ignition switch is in the ON position.

1. MAIN SWITCH OPERATION

When the main switch is pushed ON, current flows from terminal 4 of the CC ECU → terminal B-1 5 of the control switch → terminal B-20 of the switch → ground.

As a result, the CC ECU is on standby and terminal 5 of the CC ECU is grounded. Therefore the CC indicator lights up.

2. CONTROL SWITCH OPERATION

The control switch controls the SET, COAST, RESUME, ACCEL and CANCEL functions. When the control switch is turned to each position, current flows from terminals 19, 18 or 17 of the CC ECU → terminals B-5, B-11 or B-1 5 of the control switch → terminal B-20 of the switch → ground.

In the way, the CC ECU detects each position the control switch is turned to, and starts operation.

HINT: The SET function is detected by the CC ECU when the control switch released from SET/COAST.

3. SPEED CONTROL OPERATION

When the vehicle speed is set by the control switch, the ECU sends signal from terminal 10 → terminal 2 of the stop light switch → terminal 4 of the switch → terminal 5 of the actuator → (safety magnetic clutch) → terminal 4 of the actuator → ground.

At the same time, the CC ECU sends the signal from terminal 24 → terminal 1 of the actuator → (position sensor) → terminal 3 of the actuator → terminal 26 of the CC ECU. When the occurs, the position sensor sends the position of the actuator arm as a signal (voltage) from terminal 2 of the actuator to terminal 25 of the CC ECU.

When the actual vehicle speed drops below the set speed, the CC ECU sends a signal (voltage) from terminal 12 → terminal 6 of actuator → (motor) → terminal 7 of actuator → terminal 11 of CC ECU. This causes the motor to rotate the actuator arm in the throttle opening direction, increasing the vehicle speed. Then, when the arm reaches the prescribed angle, the CC ECU detects this at terminal 25 and stops the signal from 12.

When the actual vehicle speed rises above the set speed, the CC ECU sends a signal from terminal 11, turning the motor in the opposite direction so that the vehicle speed is reduced.

4. MANUAL CANCEL OPERATION

The CC system has the following methods of cancellation:

- **Speed Control Switch (CANCEL)**

When the control switch is turned to CANCEL position.

- **Parking Brake Switch**

When the parking brake lever is pulled, the parking brake switch is turned ON and sends a cancellation signal (ground voltage) to terminal 3 of the CC ECU.

- **Neutral Start Switch (A/T)**

When the shift lever is set to "N" or "P" range, the neutral start switch is turned ON and sends a cancellation signal (ground voltage) to terminal 2 of the CC ECU.

- **Stop Light Switch**

When the brake pedal is depressed, SW B of the stop light switch is turned OFF, the safty magnetic clutch (in actuator) is released, and SW A of the stop light switch is turned ON and sends a cancellation signal (battery voltage) to terminal 16 of the CC ECU.

When the CC ECU detects any of the above signals, it stops output of signals to the actuator, and cancels cruise control.

Diagnosis System

Output of Diagnostic Code

READ DIAGNOSTIC CODE

(Type A)

- (a) Turn the ignition switch on.
- (b) Turn the control switch to SET/COAST position, and keep it there.
- (c) Push the main switch ON.
- (d) Check that the indicator light "CRUISE" lights-up in the combination meter.
- (e) Turn the SET/COAST switch off.
- (f) Meet the conditions listed in the table below.
- (g) Read the diagnosis code on the cruise control indicator light.

No.	Conditions	Indication code	Diagnosis
1	Turn the control switch to SET/COAST position.		SET/COAST circuit is normal.
2	Turn the control switch to RES/ACC position.		RES/ACC circuit is normal.
3	Each cancel switch is turned ON. • Control switch (to CANCEL) • Stop light switch • Parking brake switch • Neutral start switch (to N or P range)		Each cancel switch is normal.
4	Drive at approx. 40 km/h (25 mph) or below.		Speed sensor circuit is normal.
	Drive at approx. 40 km/h (25 mph) or over		Speed sensor circuit is normal.

HINT:

- Indication codes appear in order from No.1.
- If there is no indication code, perform troubleshooting and inspection. (See page BE-110)
- Indication is stopped when the MAIN switch is repushed.

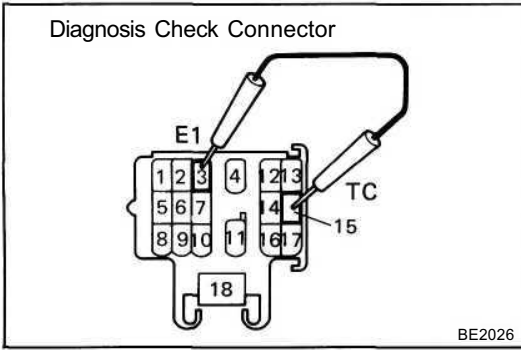

(Type B)

- (a) If while driving with the cruise control on, the system is canceled by a malfunction in either the actuator, speed sensor or speed control switch circuit, the cruise control indicator light "CRUISE" will blink 5 times.
- (b) While stopped, connect terminals 3 and 15 of the check connector.

HINT: If the ignition switch is turned off, the diagnostic code will be erased from the computer memory.

- (c) Read the diagnostic code on the indicator light "CRUISE".

	Indication code	Diagnosis
	<p>0.25S 0.25S</p> <p>BE1939</p>	Normal
11	<p>4S 1.5S 0.5S</p> <p>BE1940</p>	Excessive current flowed to motor or safety magnetic clutch drive circuit.
12	<p>0.5S 1.5S</p> <p>BE2711</p>	Open circuit in safety magnetic clutch circuit.
13	<p>BE4344</p>	<ul style="list-style-type: none"> • Position sensor circuit abnormal. • Open circuit in motor.
21	<p>BE1941</p>	Vehicle speed signal not sent for 140 msec, or longer
23	<p>BE1943</p>	*Vehicle speed has decreased by 16 km/h (10 mph) or more from the set speed during cruising.
31	<p>BE1944</p>	RESUME/ACCEL switch is ON always when MAIN switch is pushed ON.
33	<p>BE2712</p>	SET/COAST switch signal and RES/ACC switch signal turned on simultaneously.

CONTINUED ON NEXT PAGE

CONTINUED FROM PREVIOUS PAGE

Indication code		Diagnosis
41	 <small>BE4345</small>	ECU malfunction.
<p>* If the set speed can be maintained when the speed control switch is again set at SET/COAST, there is no malfunction.</p>		

HINT:

- Indication codes appear in order from No.11.
- If there is no indication code, perform troubleshooting and inspection. (See page BE-110)

Troubleshooting

You will find the source of the trouble more easily by properly using the table shown below. In this table, the numbers indicate the order of priority of the causes of trouble. Check each part in the order shown.

Chart No.			D	C	C	F	H	G	E	I	J			
Inspection Item			CC ECU	Actuator	Main Switch (in Control Switch)	Control Switch	Stop Light Switch	Neutral Start Switch	Parking Brake Switch	Speed Sensor, or Speedometer Cable	OD Solenoid Circuit (3F-E engine)	Throttle Position Sensor (3F-E engine)	Speed Control Cable and Control Link	Other Parts
Diagnosis Code	Type B	Type A												
Problem	Type B	Type A	CC ECU	Actuator	Main Switch (in Control Switch)	Control Switch	Stop Light Switch	Neutral Start Switch	Parking Brake Switch	Speed Sensor, or Speedometer Cable	OD Solenoid Circuit (3F-E engine)	Throttle Position Sensor (3F-E engine)	Speed Control Cable and Control Link	Other Parts
<ul style="list-style-type: none"> • "CRUISE" indicator light blinks 5 times. • Cruise control system does not set. • Cruise control system does not operate. 	11		2	1										
	12		3	1			2							
	21		2							1				
	23			3						2			1	
	31			2			1							
	33			2			1							
	41			1										
	Normal	4	OK	8	7	1	2	3	4	5			6	9*
		NG	2							1				
Set speed deviates on high or low side.			4	3						1			2	
Large speed increase or speed drop when the speed control switch turned to SET.			3	2								1		
Vehicle speed fluctuates when speed control switch turned to SET.			4	3						1			2	
Set speed does not cancel when brake pedal depressed.	3	OK	3	1			2							
		NG	2				1							
Set speed does not cancel when parking brake lever pulled.	3	OK	2	1										
		NG	2						1					
Set speed does not cancel when shifted to "N" range.	3	OK	2	1										
		NG	2					1						
Vehicle speed does not decrease when speed control switch turned to COAST.	1	OK	4	1						3			2	
		NG	2			1								
Vehicle speed does not accelerate when speed control switch turned to ACCEL.	2	OK		1						3	4		2	
		NG	2			1								
Vehicle speed does not return to memorized speed when control switch turned on RESUME.	2	OK	4	1						3			2	
		NG	2			1								
Set speed does not cancel when speed control switch turned to CANCEL.	3	OK	2	1										
		NG	2			1								
Speed can be set below about 40 km/h (25 mph).	4	OK	2	1										
		NG	2							1				
Cruise control will not disengage even at about 40 km/h (25 mph).	4	OK	2	1										
		NG	2							1				
Acceleration response is sluggish when speed control switch turned to "ACCEL" or "RESUME".			6	3		1					4	5	2	

*: Inspect the wire harness.

A POWER SOURCE CIRCUIT

HINT: While carrying out the following inspection, make certain that the connectors and terminals are properly connected.

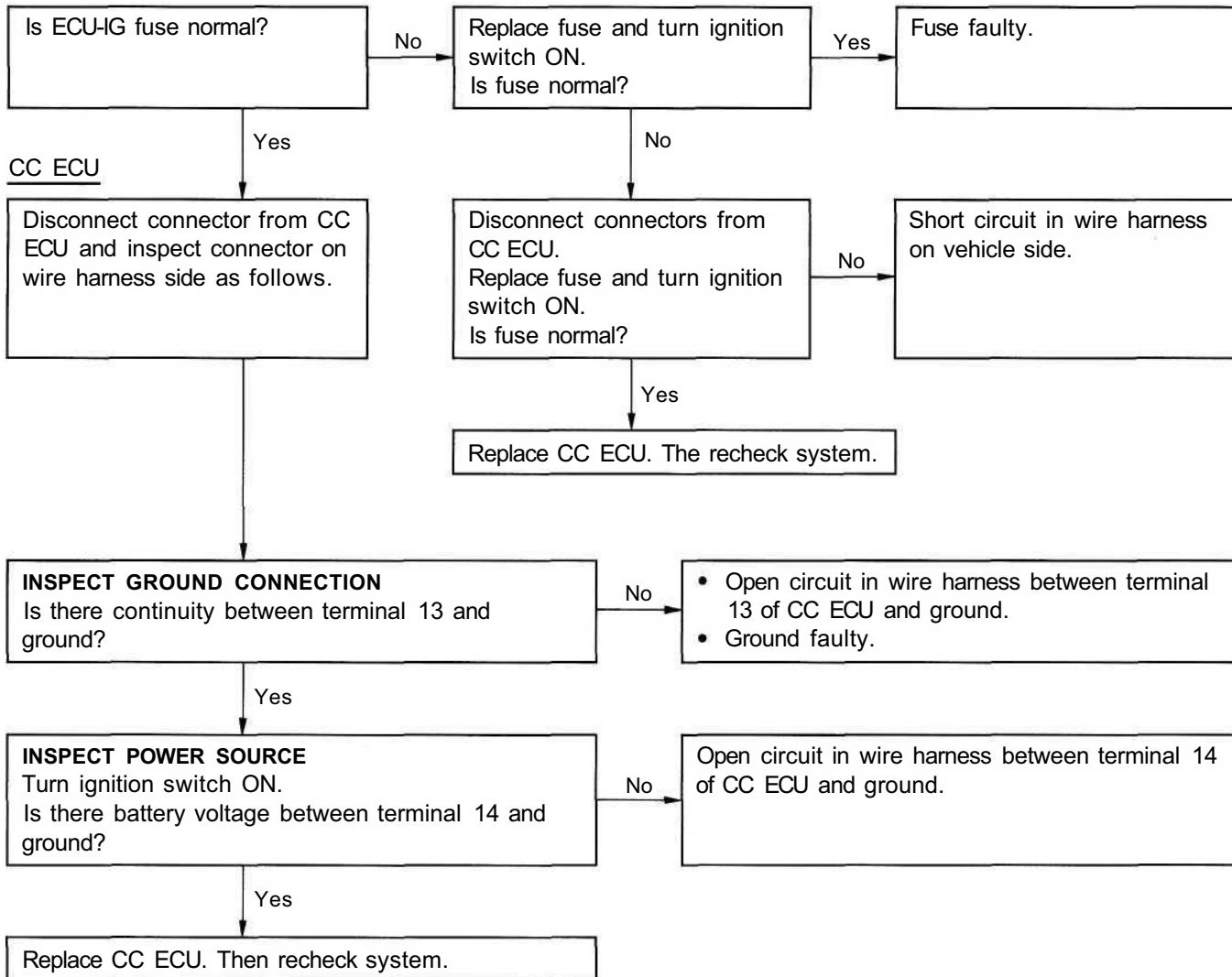

CC: Cruise Control

B CRUISE CONTROL INDICATOR CIRCUIT

HINT: While carrying out the following inspection, make certain that the connectors and terminals are properly connected.

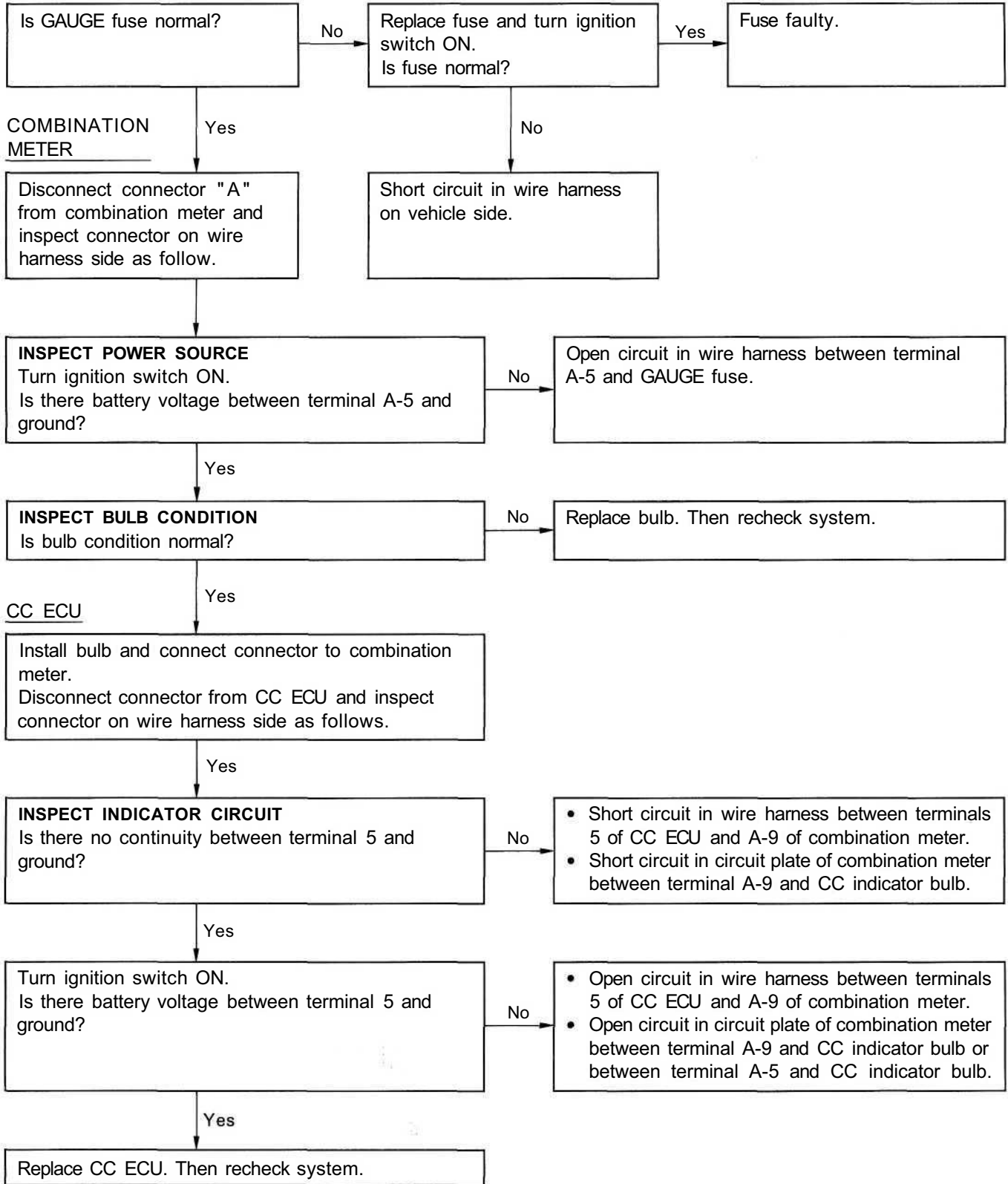

CC: Cruise Control

C CONTROL SWITCH CIRCUIT

HINT: While carrying out the following inspection, make certain that the connectors and terminals are properly connected.

CONTROL SWITCH

Disconnect connector from control switch and inspect connector on wire harness side as follows.

INSPECT GROUND CONNECTION
Is there continuity between terminal B-20 and ground?

No

- Open circuit in wire harness between terminal B-20 of control switch and ground.
- Ground faulty.

Yes

INSPECT CONTROL SWITCH (See page BE-123)
Is control switch operation normal?

No

Replace control switch. Then recheck system.

Yes

CCECU

Connect connector to control switch. Disconnect connectors from CC ECU and inspect connectors on wire harness side as follows.

INSPECT MAIN SWITCH CIRCUIT
Is there no continuity between terminal 4 and ground with main switch OFF?

No

Short circuit in wire harness between terminals 4 of CC ECU and B-15 of control switch.

Yes

Is there continuity between terminal 4 and ground with main switch ON?

No

Open circuit in wire harness between terminals 4 of CC ECU and B-15 of control switch.

Yes

INSPECT CONTROL SWITCH CIRCUIT
Is there no continuity between terminal 19, 18 or 17 and ground with control switch OFF?

No

Short circuit in wire harness between terminals 19, 18, 17 of CC ECU and B-5, B-17, B-11 of control switch.

Yes

Is there continuity as shown in table below between terminal XX and ground when control switch is turned to each position?

No

Open circuit in wire harness between terminals XX of CC ECU and YY of control switch.

Position	Terminal XX
SET/COAST	19
RES/ACC	18
CANCEL	17

Terminal XX	Terminal YY
18	B-17
19	B-5
17	B-11

Yes

Replace CC ECU. Then recheck system.

CC: Cruise Control

D ACTUATOR CIRCUIT

HINT: While carrying out the following inspection, make certain that the connectors and terminals are properly connected.

ACTUATOR

Disconnect connector from actuator and inspect connector on wire harness side as follows.

INSPECT GROUND CONNECTION
Is there continuity between terminal 4 and ground?

No

- Open circuit in wire harness between terminal 4 of actuator and ground.
- Ground faulty.

Yes

INSPECT ACTUATOR (See page BE-124)
Is actuator operation normal?

No

Replace actuator. Then recheck system.

Yes

STOP LIGHT SWITCH

INSPECT STOP LIGHT SWITCH INSTALLATION
Is stop light switch installed properly?

No

Reinstall stop light switch properly. Then recheck system.

Yes

Connect connector to actuator.
Disconnect connector from stop light switch and inspect connector on wire harness side as follows.

INSPECT SAFETY MAGNETIC CLUTCH CIRCUIT
Is there approx. 38.5 Q between terminal 4 and ground?

No

Open or short circuit in wire harness between terminals 4 of stop light and 5 of actuator.

Yes

INSPECT STOP LIGHT SWITCH (See page BE-123)
Is stop light switch operation normal?

No

Replace stop light switch. Then recheck system.

Yes

CONTINUED ON NEXT PAGE

CC: Cruise Control

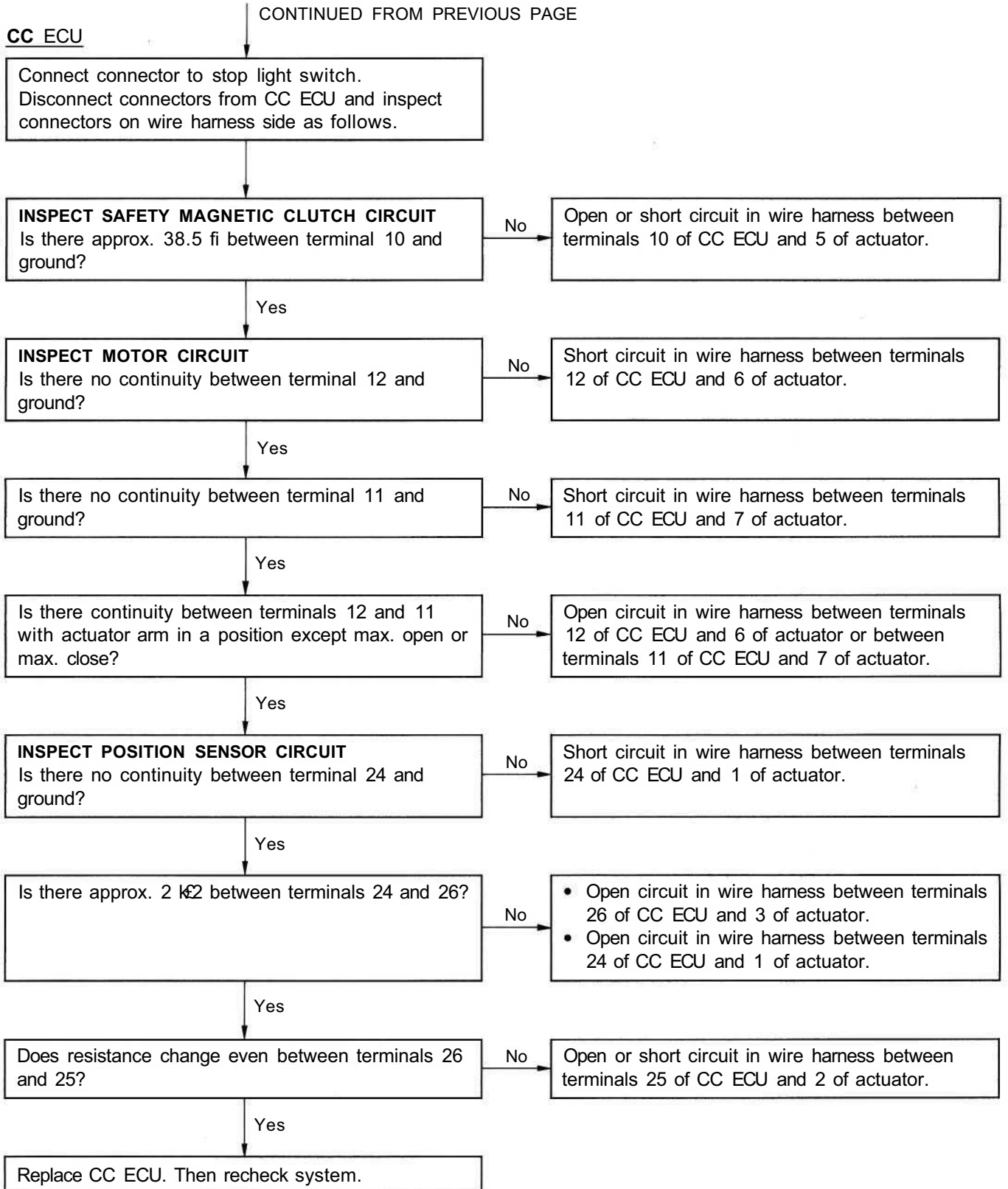

CC: Cruise Control

E SPEED SENSOR CIRCUIT

HINT: While carrying out the following inspection, make certain that the connectors and terminals are properly connected.

SPEED SENSOR

Disconnect connector from speed sensor and inspect connector on wire harness side as follows.



INSPECT GROUND CONNECTION
Is there continuity between terminal 3 and ground?

No →
• Open circuit in wire harness between terminal 3 of speed sensor and ground.
• Ground faulty.



INSPECT SPEED SENSOR (See page BE-123)
Is speed sensor operation normal?

No → Replace speed sensor. Then recheck system.



CC ECU

Connect connector to speed sensor. Disconnect connector from CC ECU and inspect connector on wire harness side as follows.



INSPECT SPEED SENSOR CIRCUIT
Is there continuity repeatedly between terminal 20 and ground?

No →
• Open or short circuit in wire harness between terminals 20 of CC ECU and 2 of speed sensor.



Replace CC ECU. Then recheck system.

CC: Cruise Control

F STOP LIGHT SWITCH CIRCUIT

HINT: While carrying out the following inspection, make certain that the connectors and terminals are properly connected.

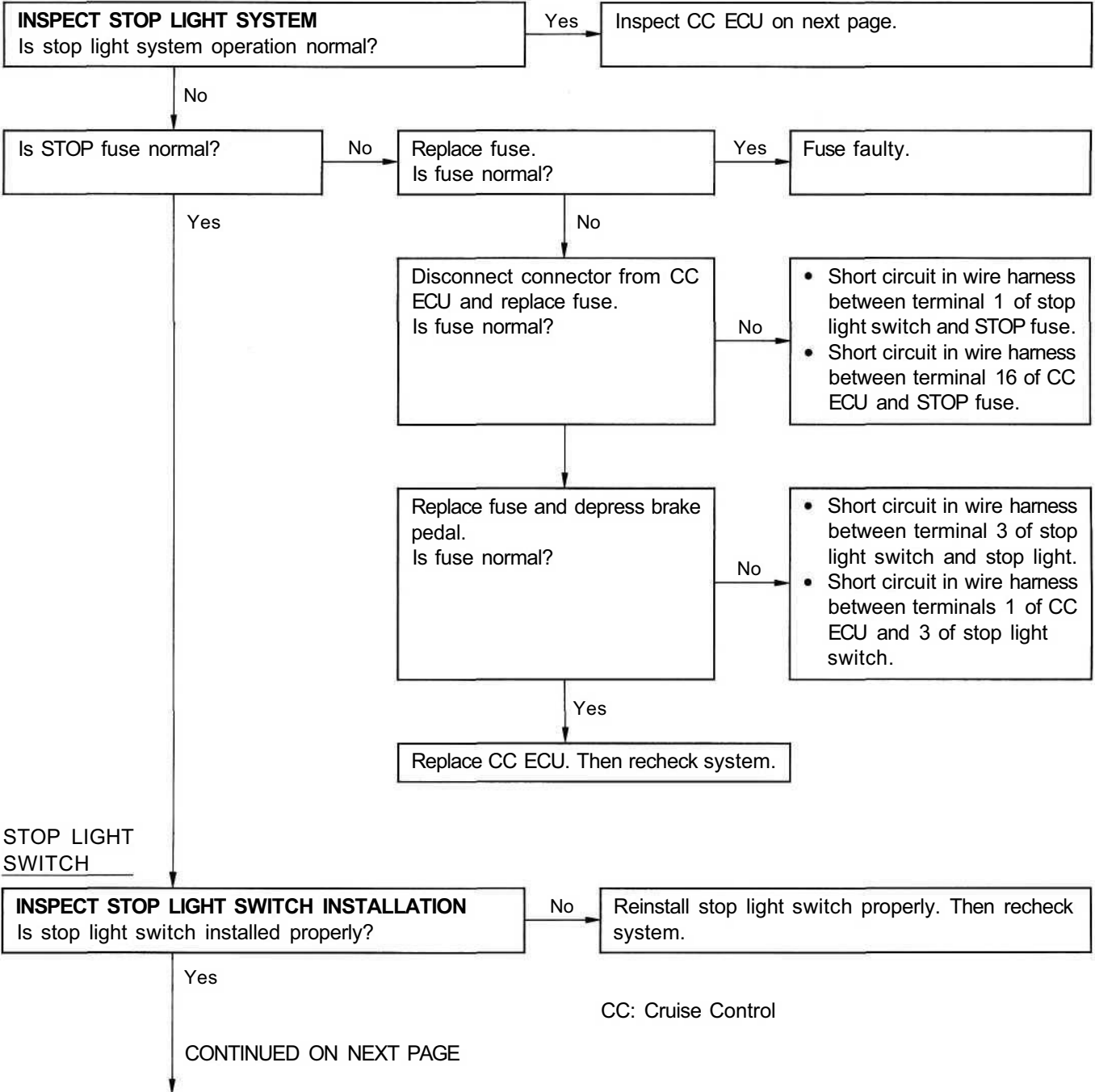

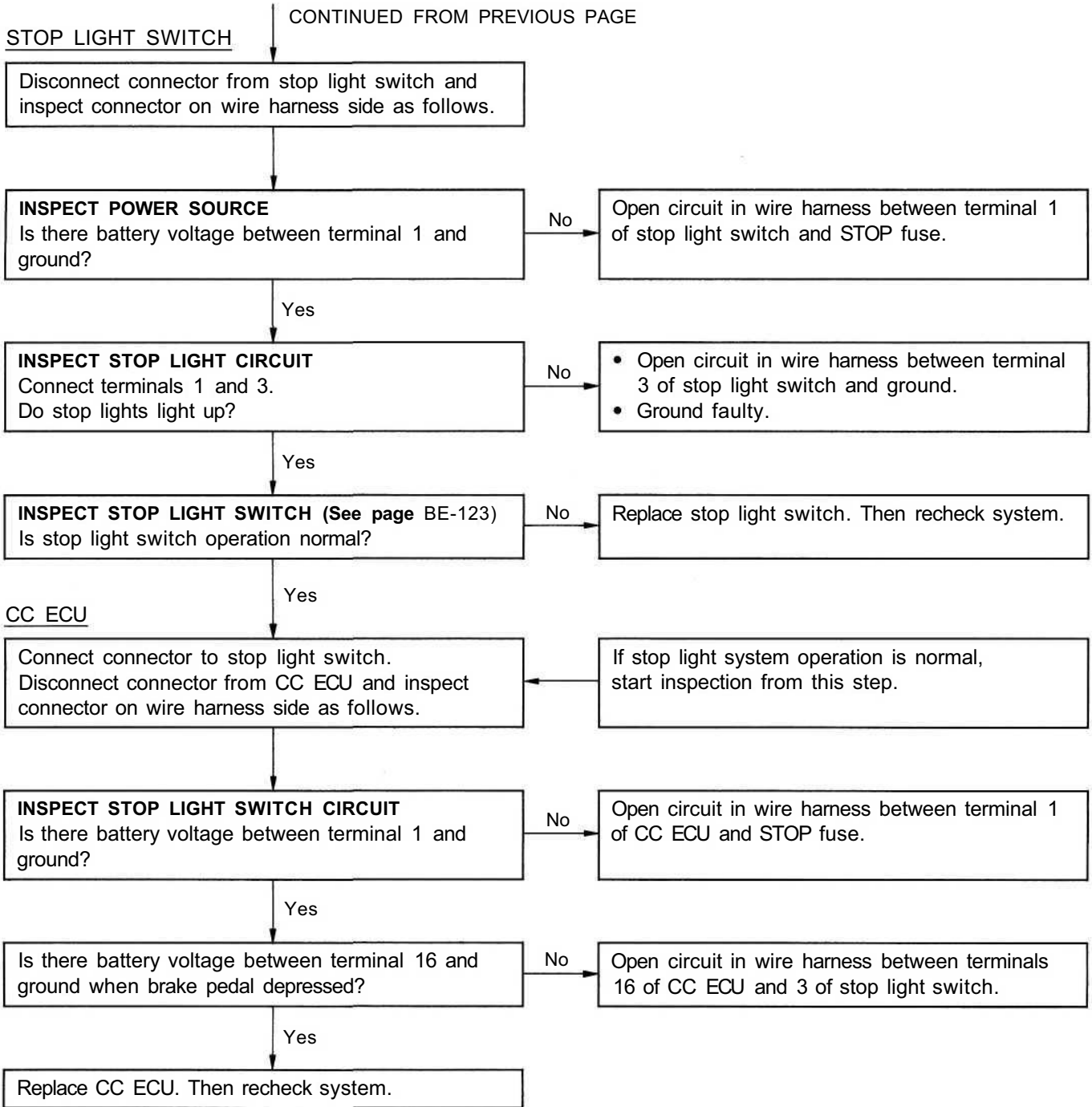

CC: Cruise Control

G | PARKING BRAKE SWITCH CIRCUIT

HINT: While carrying out the following inspection, make certain that the connectors and terminals are properly connected.

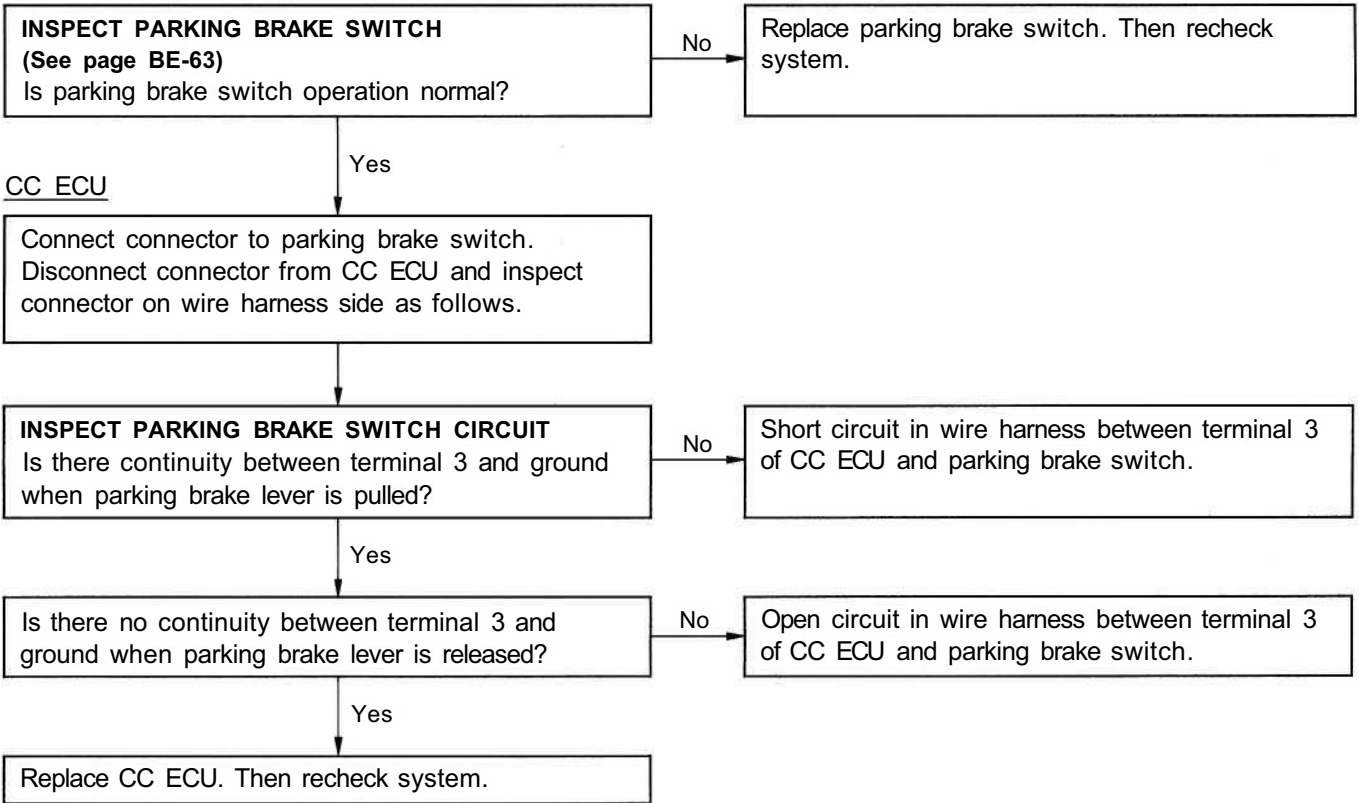

CC: Cruise Control

H NEUTRAL START SWITCH CIRCUIT

HINT: While carrying out the following inspection, make certain that the connectors and terminals are properly connected.

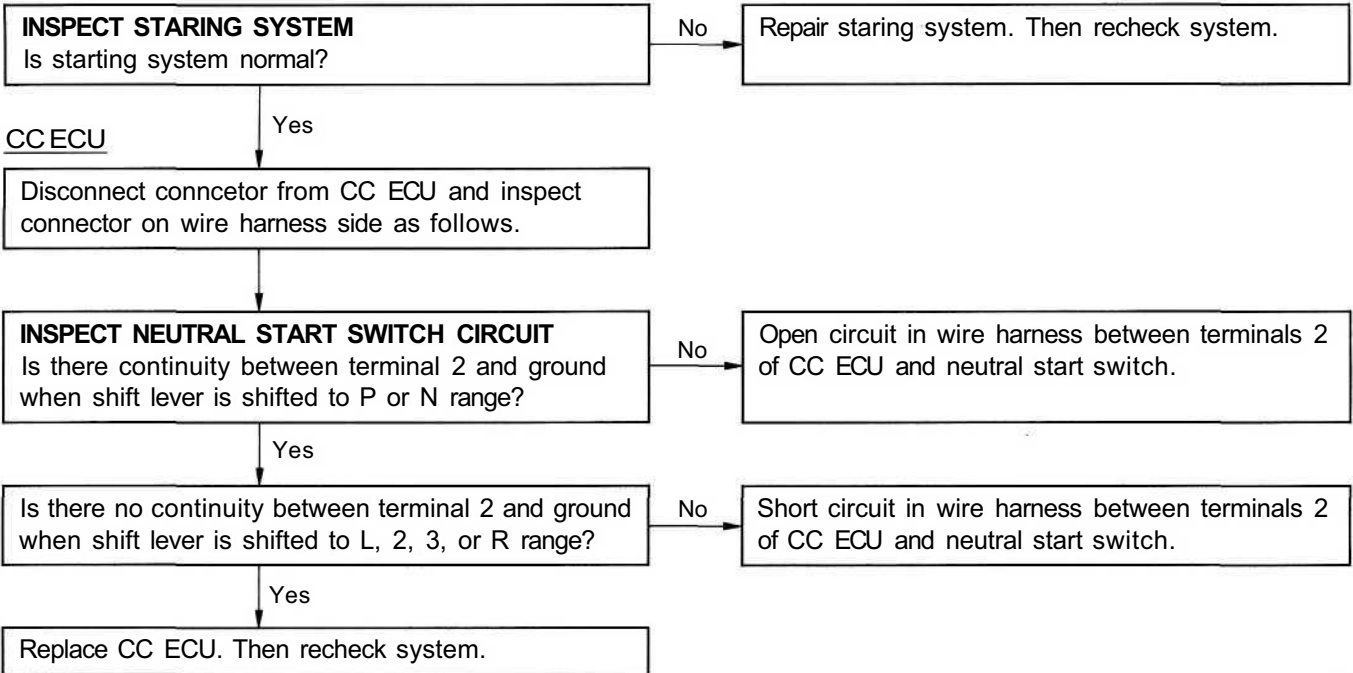

CC: Cruise Control

I OD SOLENOID CIRCUIT (w/ 3F-E Engine)

HINT: While carrying out the following inspection, make certain that the connectors and terminals are properly connected.

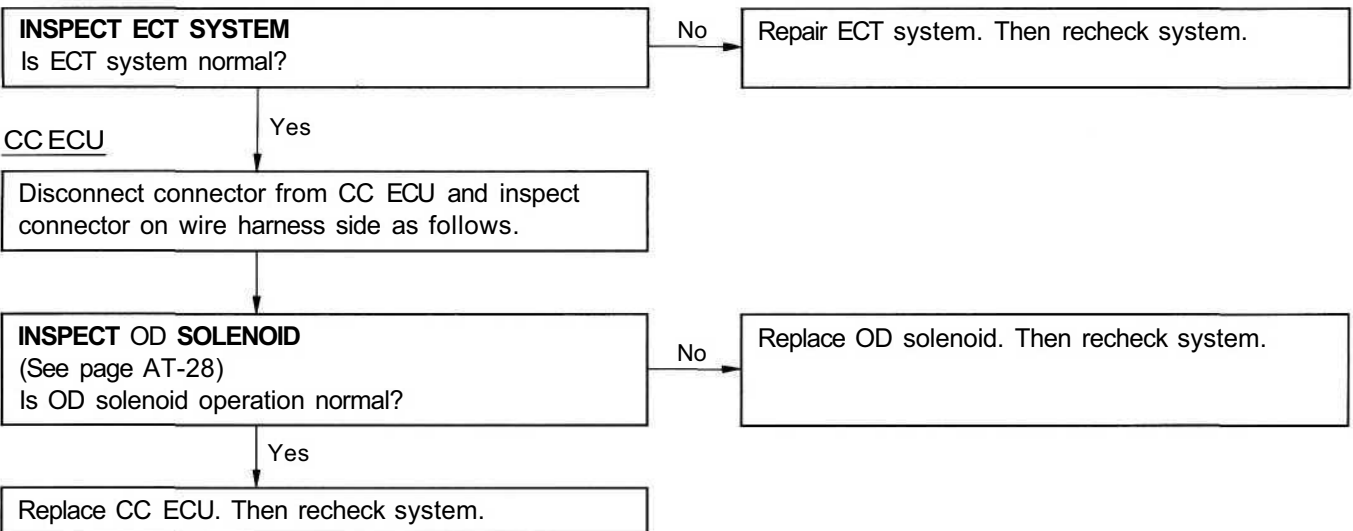

CC: Cruise Control

J IDL SIGNAL CIRCUIT (w/ 3F-E Engine)

HINT: While carrying out the following inspection, make certain that the connectors and terminals are properly connected.

THROTTLE POSITION SENSOR

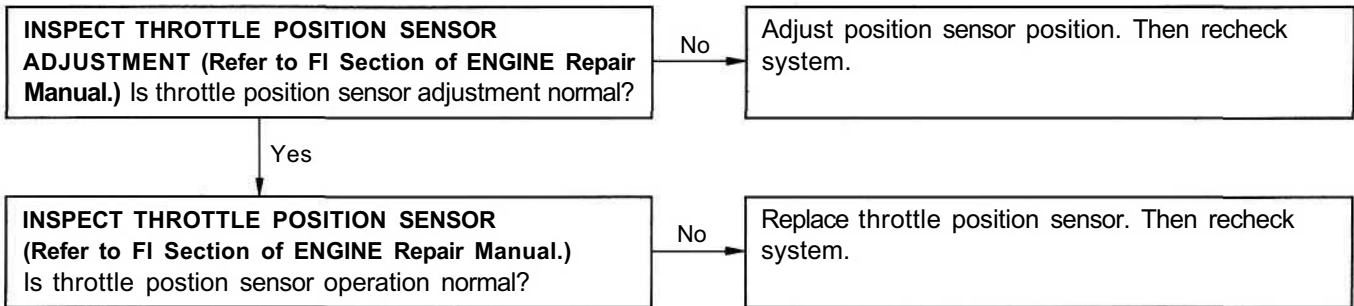

CCECU

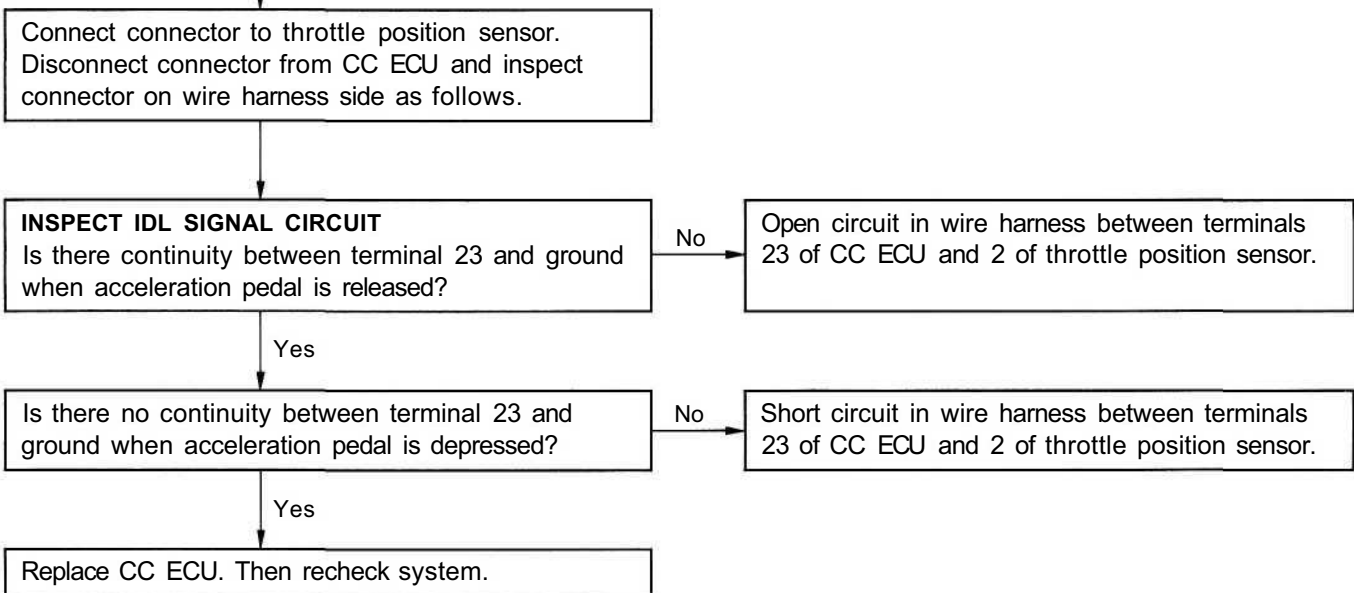

CC: Cruise Control

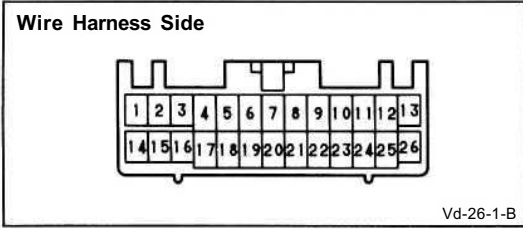

Cruise Control ECU Circuit

INSPECT ECU CIRCUIT

Disconnect connector and inspect connector on wire harness side as shown in the chart.

Check for	Measured item	Tester connection	Condition		Specified value
Continuity	Neutral start switch	2 — ground	Shift lever position	N or P	Continuity
				L, 2, D or R	No continuity
	Parking brake switch	3 — ground	Parking brake lever position	released	No continuity
				pulled	Continuity
	Control switch	4 — ground	Main switch position	OFF	No continuity
				ON	Continuity
	Ground connection	13 — ground	Constant		Continuity
	Control switch	18 — ground	Control switch position	RES/ACC	Continuity
			Control switch position	SET/COAST	Continuity
			Control switch position	CANCEL	Continuity
Actuator (motor)	•11 _ 12	Actuator arm position	max. OPEN	(12 → 11) Continuity	
			max. CLOSE	(11 → 12) Continuity	
			any position except above position	(12 → 11) Continuity	
TDCL circuit	8 — ground	Constant		No continuity	
		Terminals Tc and E1 connected		Continuity	
Throttle position sensor (IDL: 3F-E Engine)	23 — ground	Acceleration pedal position	released	Continuity	
			depressed	No continuity	
Speed sensor	20 — ground	With ignition switch ON, speedometer shaft or speed sensor shaft turned.		Continuity No continuity	
Resistance	Actuator (position sensor)	24 - 26	Constant		Approx. 2 kΩ
		24 - 25	Actuator arm turned	Resistance change even	
	Actuator (Safety magnetic clutch)	10 — ground	Brake pedal position	released	Approx. 38.5 Ω
depressed				No continuity	
Voltage	Power source	14 — ground	Ignition switch position	LOCK or ACC	No voltage
				ON	Battery voltage
	STOP fuse	1 — ground	Constant		Battery voltage
	Stop light	16 — ground	Brake pedal position	released	No voltage
				depressed	Battery voltage
	O/D solenoid valve (3F-E Engine)	9 — ground	Ignition switch position	LOCK or ACC	Battery voltage
ON				No voltage	

*: This circuit includes the diode. If the circuit shown no continuity, change the positive and negative probes and recheck system.

If circuit is as specified, try another ECU.
If circuit is not as specified, refer to BE-104 wiring diagram and inspect the circuits connected to other parts.

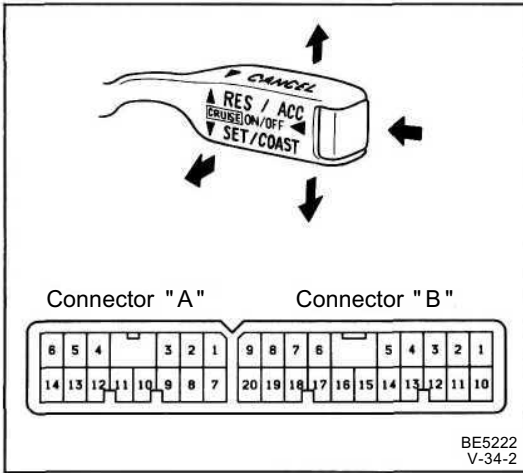

Parts Inspection

1. INSPECT SWITCHES (Control Switch/Continuity)

Terminal		B20	B11	B5	B17	B15
Main	ON	○	—	—	—	○
	OFF					
Control	RES/ACC	○	—	—	○	
	SET/COAST	○	—	○		
	CANCEL	○	○			

If the continuity is not as specified, replace the control switch.

(Stop Light Switch/Continuity)

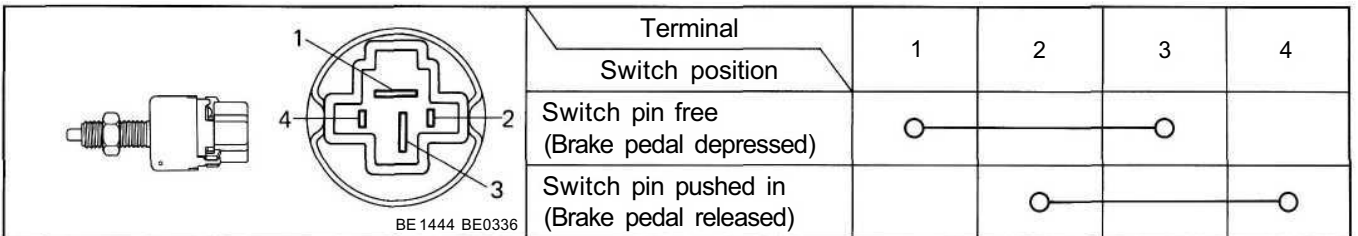

If continuity is not as specified, replace the stop light switch.

(Neutral Start Switch)

See page AT-28.

(Parking Brake Switch)

See page BE-63.

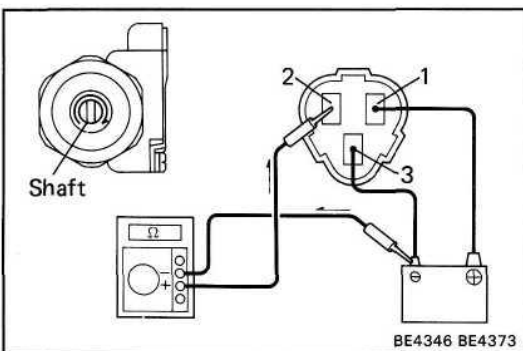

2. INSPECT SPEED SENSOR

- Connect the positive (+) lead from the battery to terminal 1 and the negative (-) lead to terminal 3.
- Check that there is continuity between terminal 2 and the battery negative (-) terminal four times per each revolution of the shaft.

HINT: Connect the test leads so that the current from the ohmmeter can flow from terminal 2 to battery negative (-) terminal.

If operation is not as specified, replace the speed sensor.

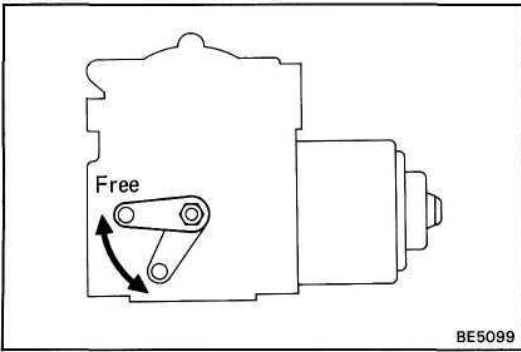

3. INSPECT ACTUATOR
(Safety Magnet Clutch)

(a) Check that the arm moves smoothly by hand.

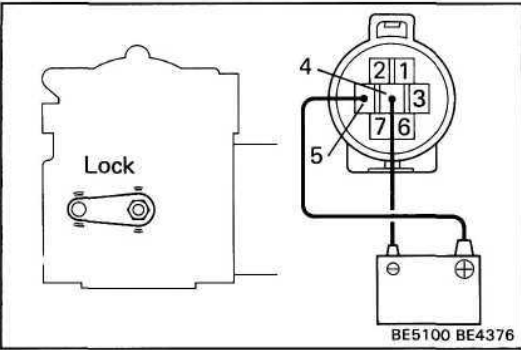

(b) Connect the positive (+) lead from the battery to terminal 5 and the negative (—) lead to terminal 4. (Safety magnet clutch turned ON)

(c) Check that the arm does not move by hand.

If operation is not as specified, replace the motor.

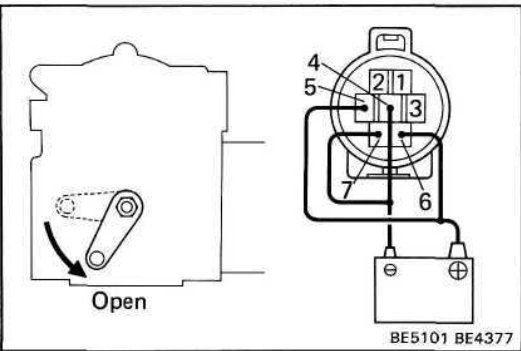

(Motor)

(a) With the safety magnetic clutch ON, connect the positive (+) lead from the battery to terminal 6 and the negative (—) lead to terminal 7, check that the arm moves to the open side.

(b) When the arm reached to the open position, check that the motor operation stops.

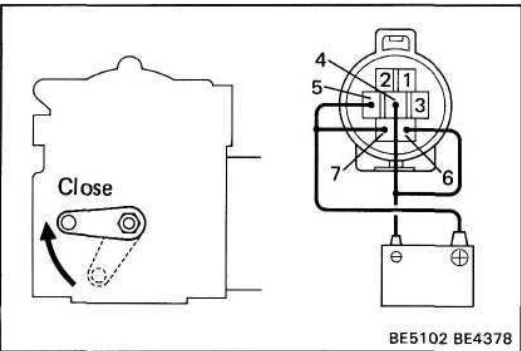

(c) With the safety magnetic clutch ON, connect the positive (+) lead from the battery to terminal 7 and the negative (—) lead to terminal 6, check that the arm moves to the close side.

(d) When the arm reaches to the closed position, check that the motor operation stops.

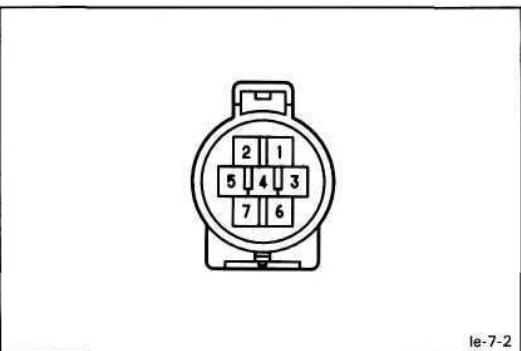

(Position Sensor)

(a) Measure the resistance between terminals 1 and 3.

Resistance: Approx. 2 kΩ

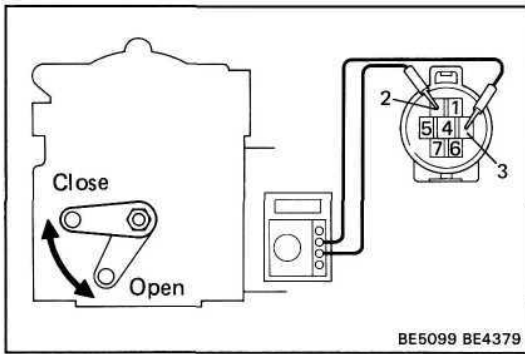

- (b) When the arm is moving from the closed to open position, check that resistance between terminals 2 and 3 increases from approx. 0.5 to 1.7 kfi.

If operation is not as specified, replace the motor.

**4. (3F-E Engine)
INSPECT THROTTLE POSITION SWITCH
(Refer to FI section of Engine Repair Manual)**

Adjustment of Control Link Assembly

ADJUST CONTROL LINK ASSEMBLY

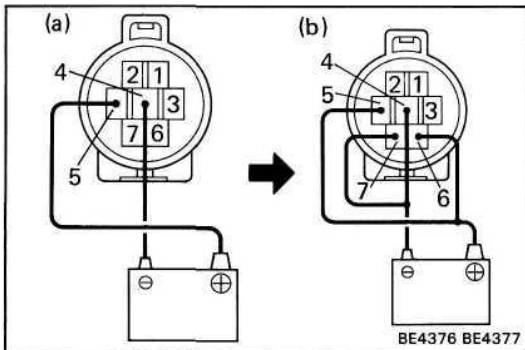

- (a) Connect the positive (+) lead from the battery to terminal 5 and the negative (-) lead to terminal 4 of the actuator.
(Safety magnet clutch turned ON)

NOTICE: Keep the safety magnet clutch ON until adjustment of control link assembly is completed.

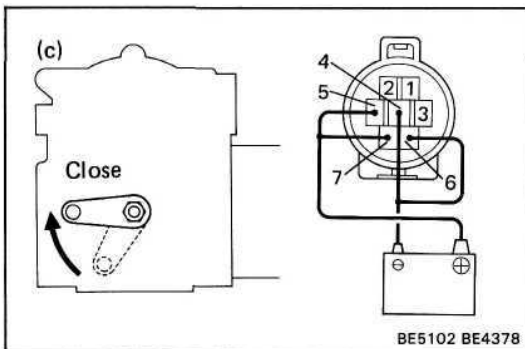

- (b) With the safety magnetic clutch ON, connect the positive (+) lead from the battery to terminal 6 and the negative (-) lead to terminal 7.
(Arm moves to the open side.)
- (c) With the safety magnetic clutch ON, connect the positive (+) lead from the battery to terminal 7 and the negative (-) lead to terminal 6.
(Arm moves to the close side.)
- (d) Install the control link assembly to the actuator.

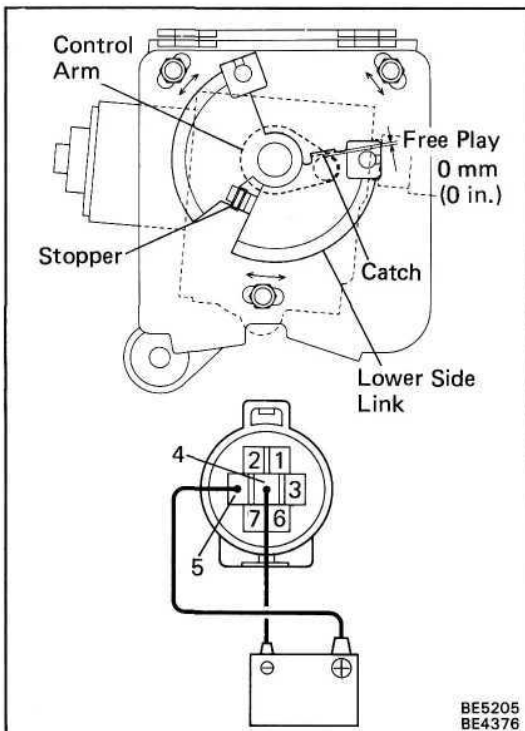

- (e) Rotate the control link assembly so that the catch of the control link assembly's lower side link comes in contact with the actuator control arm (Free play 0).

Free play: 0 mm (0 in.)

NOTICE: Rotate the lower side link to the right until it touches the stopper.

- (f) In condition (d), install and torque the three nuts.
- (g) Disconnect lead wire from the actuator.

FUEL TRANSFER SYSTEM

Parts Location

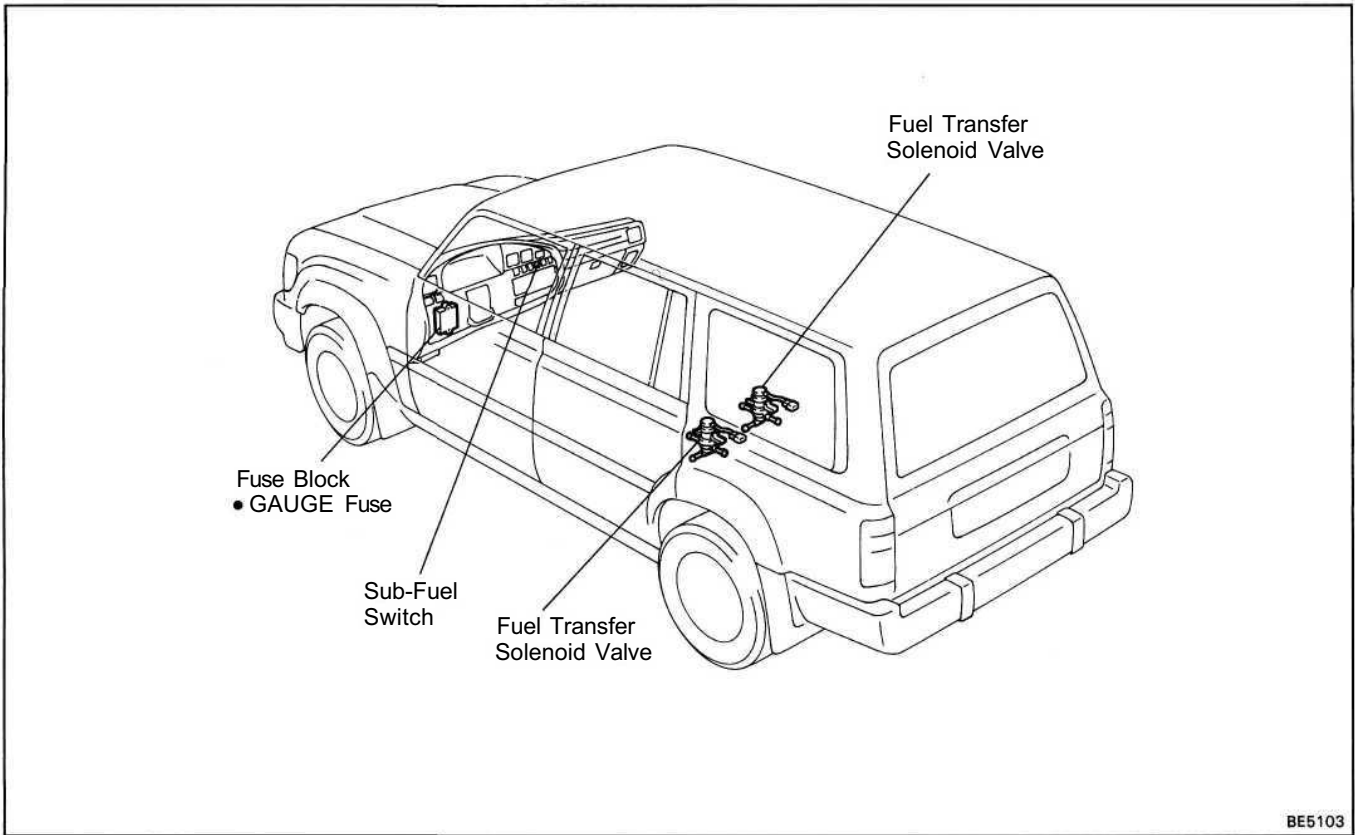

BE5103

Wiring and Connector Diagrams

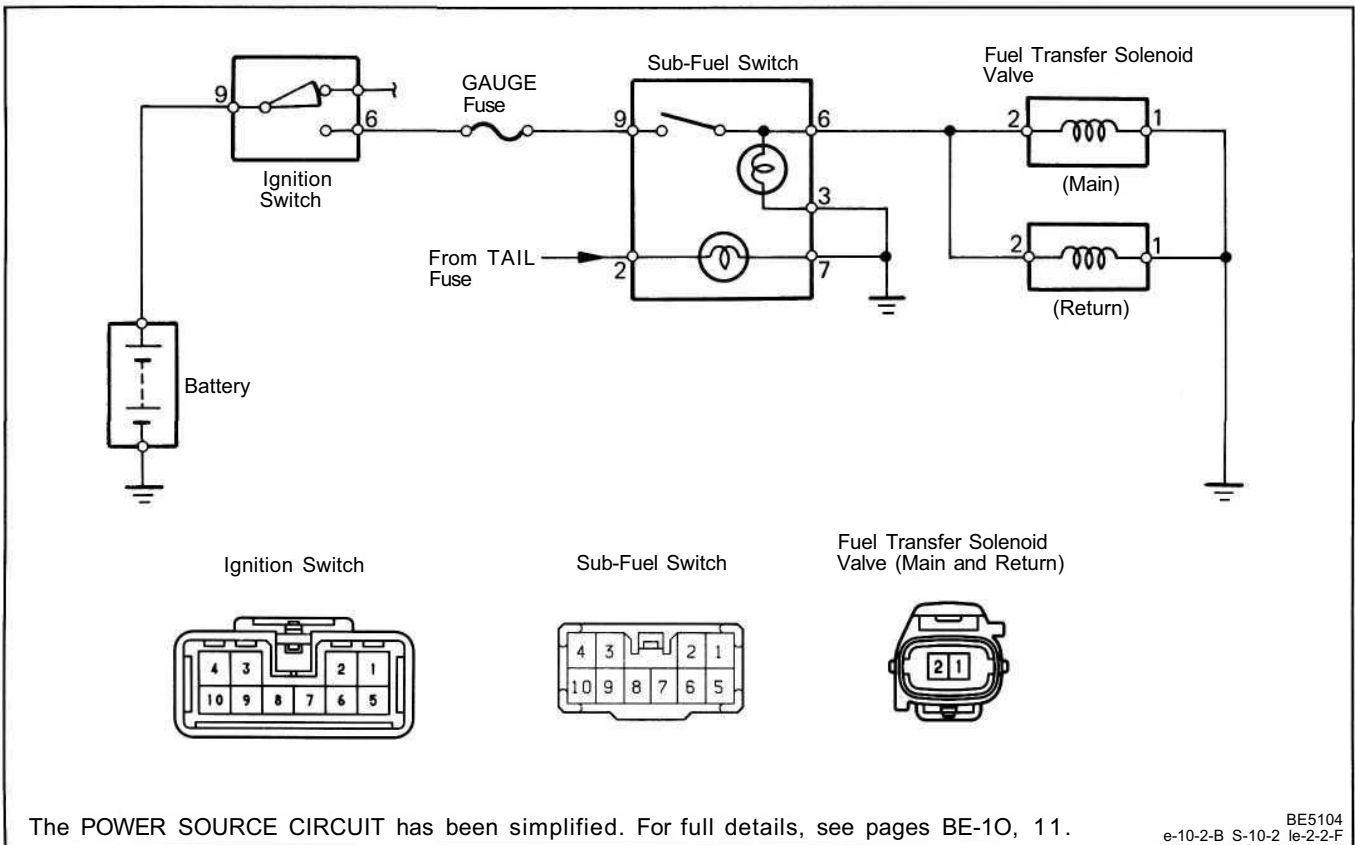

System Description

Standby Operation

- When the Ignition Switch is on, current flows from the battery to terminal 9 of the Sub Fuel Switch.

Operation

Sub-Fuel Switch "OFF" (Fuel)

Fuel tank (Main) → Solenoid valve (Main) C port → Solenoid valve (Main) B port → Engine → Solenoid valve (Return) B port → Solenoid valve (Return) C port → Fuel tank (Main)

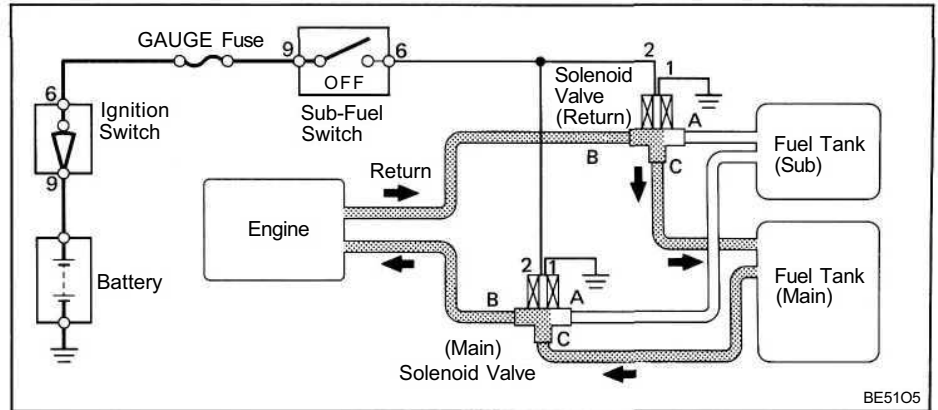

Sub-Fuel Switch "ON" (Current)

When the Sub-fuel switch is set to "ON" current flows through terminal 9 of sub-fuel switch → terminal 6 → terminal 2 of solenoid valve (Main and Return) → terminal 1 → ground

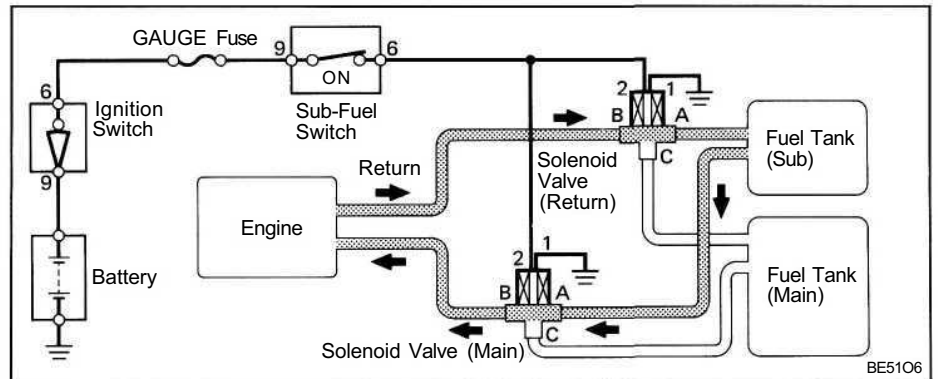

(Fuel)





Fuel tank (sub) → Solenoid valve (Main) A port → Solenoid valve (Main) B port → Engine → Solenoid valve (Return) B port → Solenoid valve (Return) A port → Fuel tank (Sub)

Troubleshooting

Problem	Possible cause	Remedy	Page
Fuel Transfer System do not operate	GAUGE fuse blown Sub fuel switch faulty Fuel transfer solenoid valve (Main and return) faulty Wiring or ground faulty	Replace fuse and check for short Check switch Check solenoid valve Repair as necessary	BE-4, 6 BE-128 BE-128

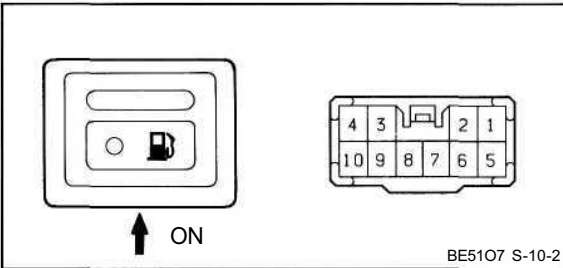
Parts Inspection

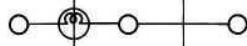
1. INSPECT SUB FUEL SWITCH (Continuity)

 <p>BE5107 S-10-2</p>	Terminal	3	6	9	Illumination	
	Switch Position				2	7
	OFF					
ON						

If continuity is not as specified, check the bulb or replace the switch.

2. INSPECT FUEL TRANSFER SOLENOID VALVE (Main)

- (a) Check that the air flows between ports B and C. Check that the air does not flow between ports A and B.

Port Condition	A	B	C
No voltage			

- (b) Apply the battery voltage across the terminals. Check that the air flows between ports A and B. Check that the air does not flow between ports B and C.

Port Condition	A	B	C
Apply the battery voltage			

If operation is not as specified, replace the solenoid.

(Return)

The inspection is the same as for the main solenoid valve.

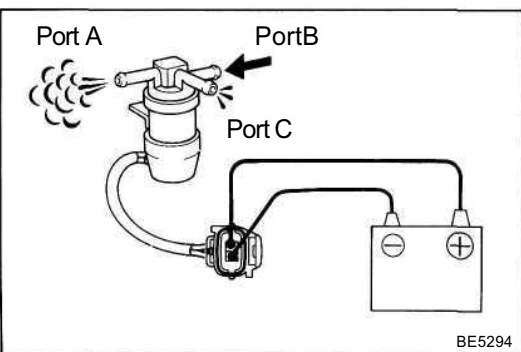
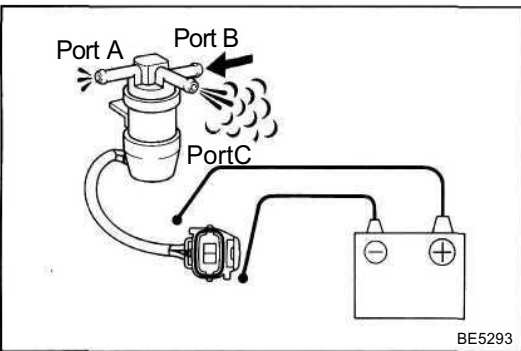

AUDIO SYSTEM

Parts Location

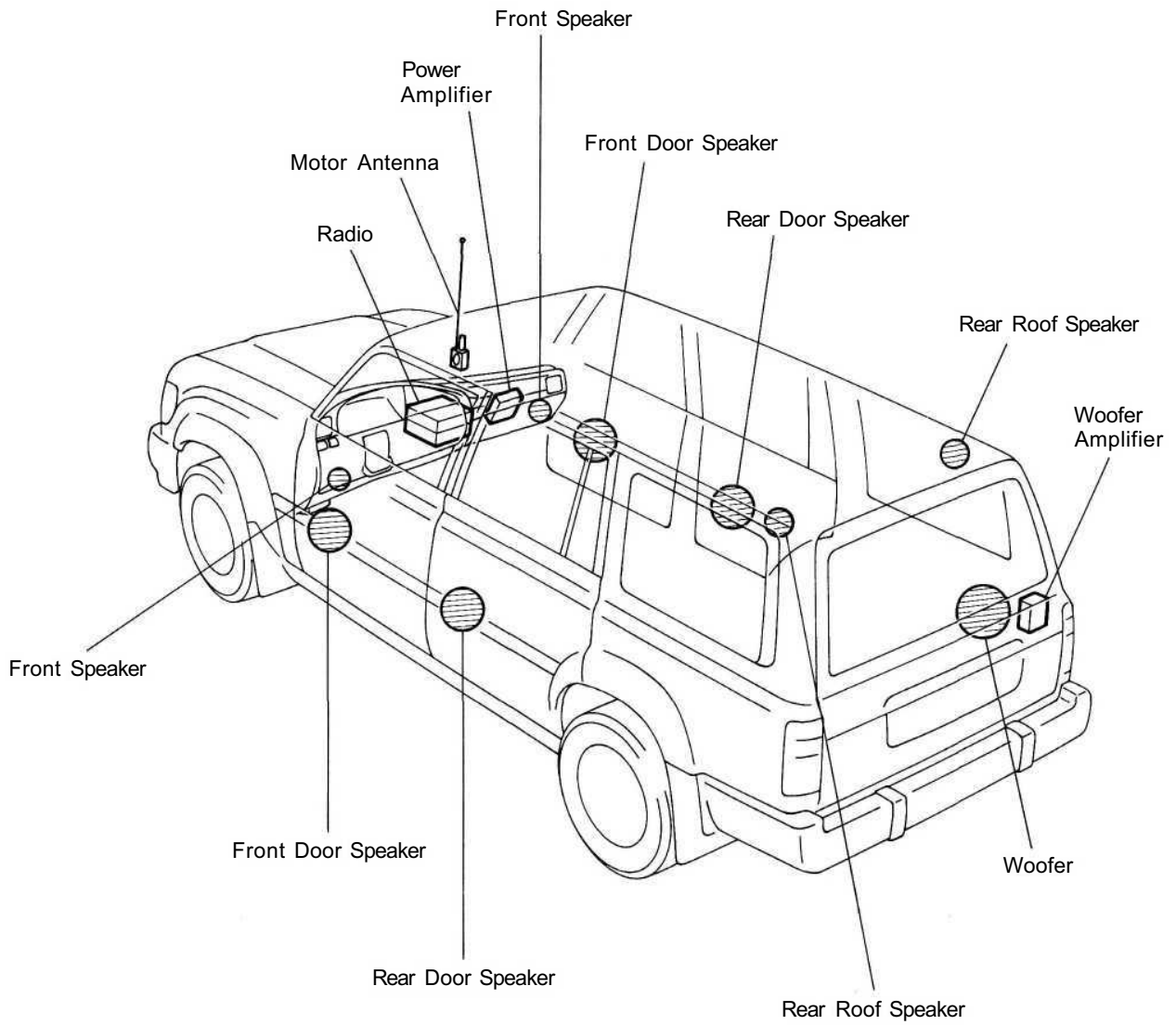

Wiring and Connector Diagrams

Radio, 1 Speaker: Symbol **R**

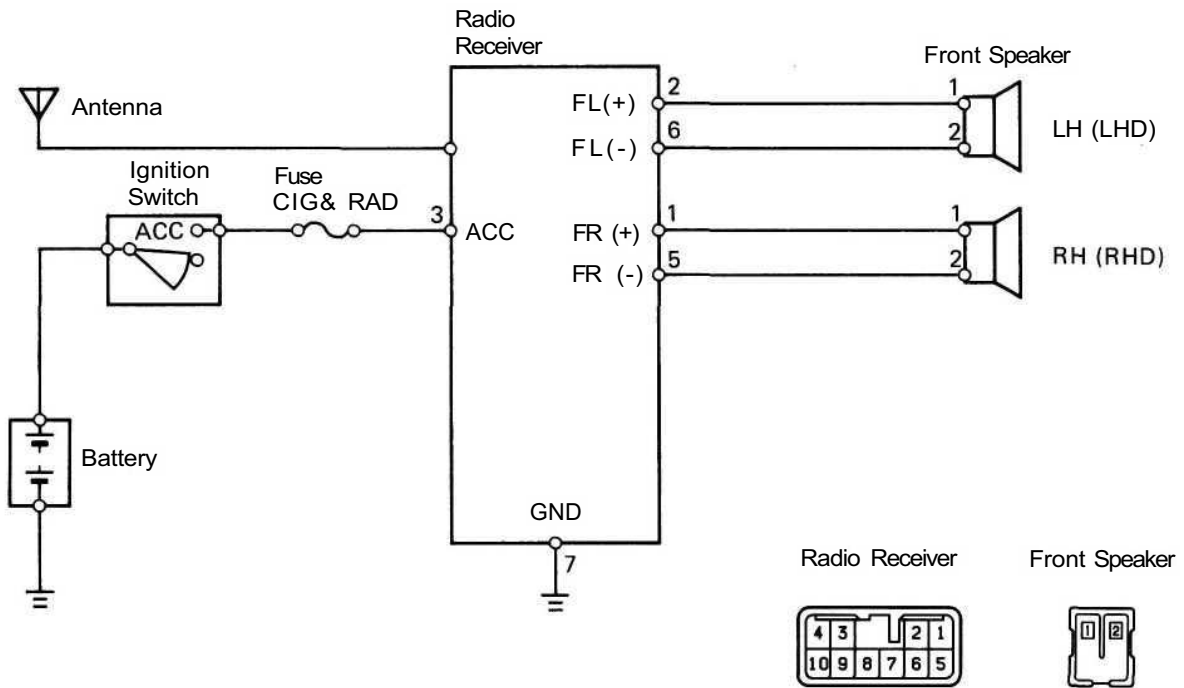

Radio, ETR, 2 Speaker: Symbol **R**

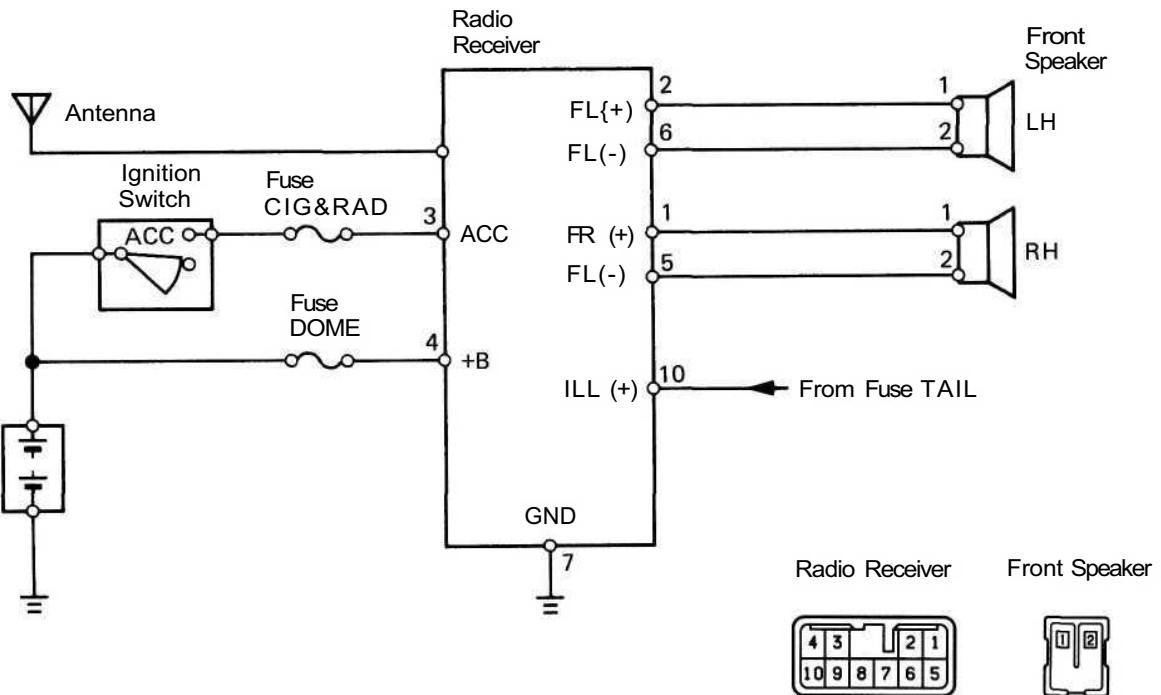

Radio, ETR, 2 Speaker + Tape Player: Symbol **S**

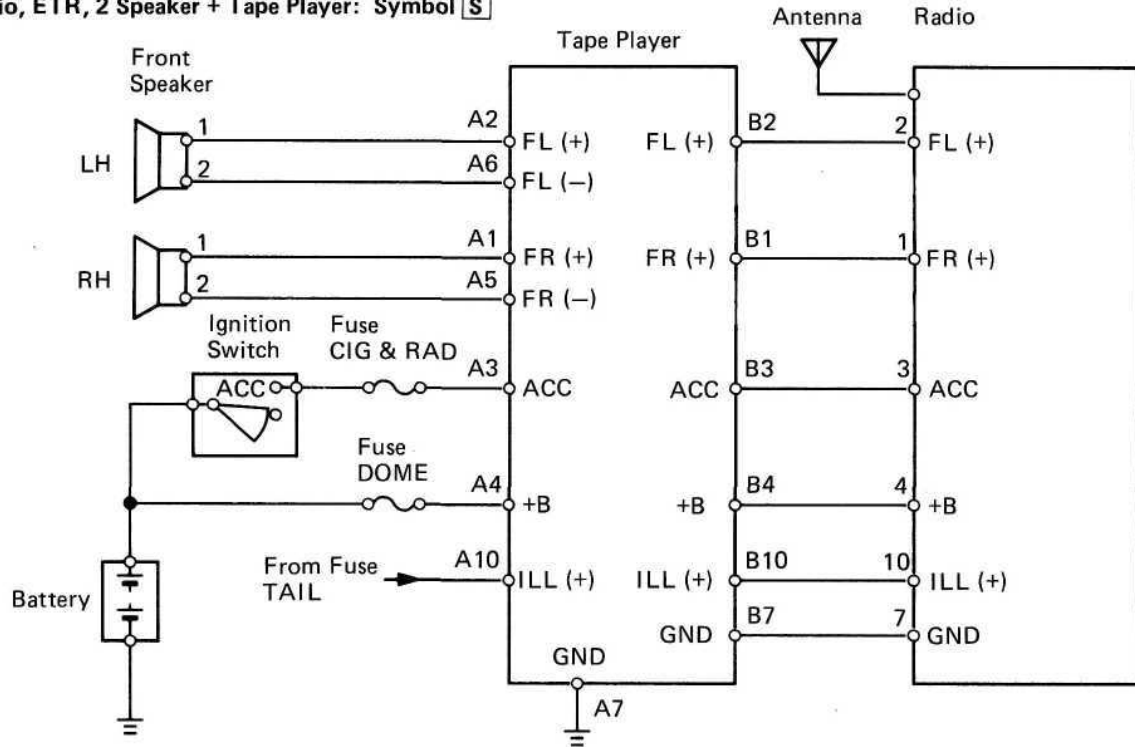

Tape Player Connector "A"

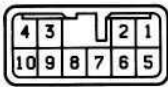

Connector "B"

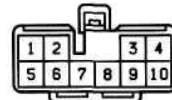

Radio

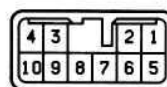

Speaker



Radio - Tape Player, 5 Speaker: Symbol **U**

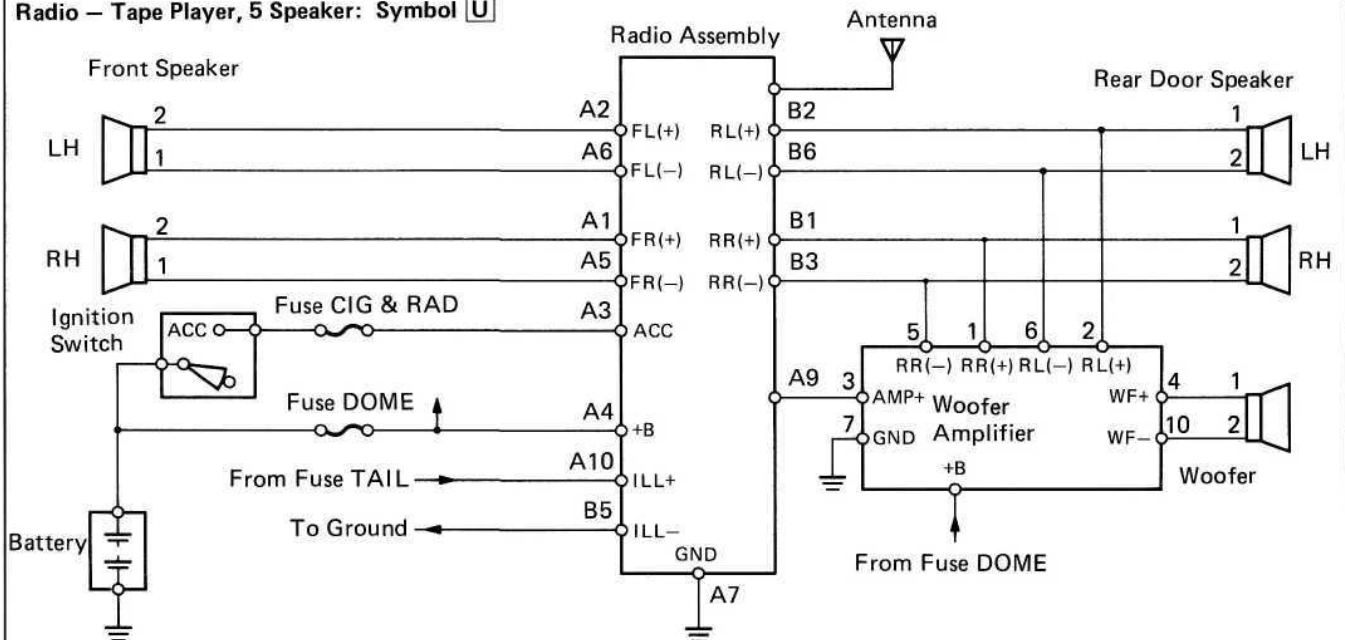

Radio Assembly Connector "A"

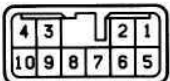

Connector "B"

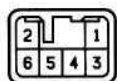

Woofer Amplifier

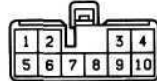

Front Speaker



Rear Door Speaker



Woofer

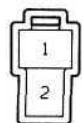

Radio - Tape Player, 5 Speaker, w/ Radio Linked Motor Antenna: Symbol **U**

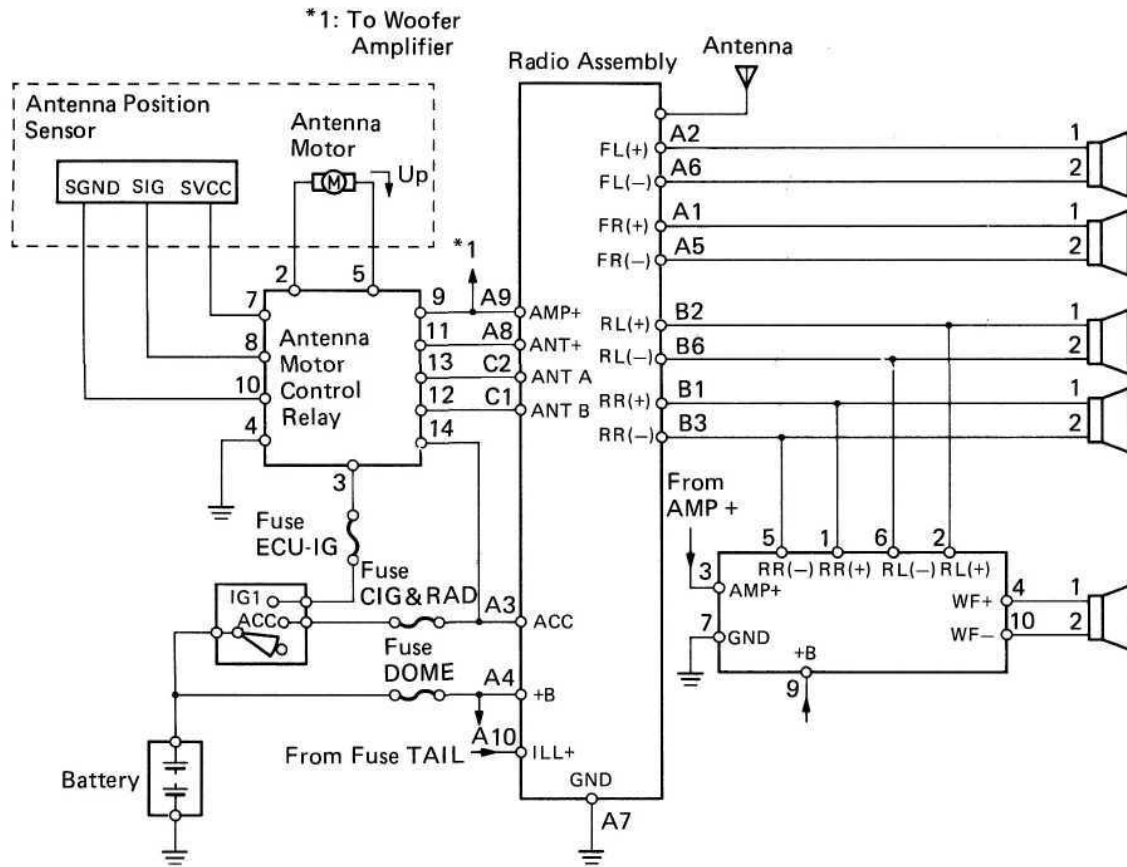

Radio Assembly Connector "A"

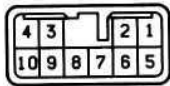

Connector "B"

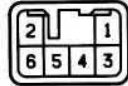

Connector "C"



Antenna Motor Control Relay

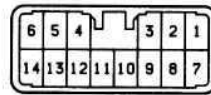

Woofer Amplifier

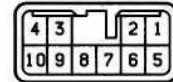

Front Speaker



Rear Speaker



Woofer

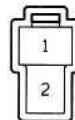

Radio - Tape Player, 9 Speaker } Symbol P
 Radio - Tape Player, 9 Speaker + CD Player }

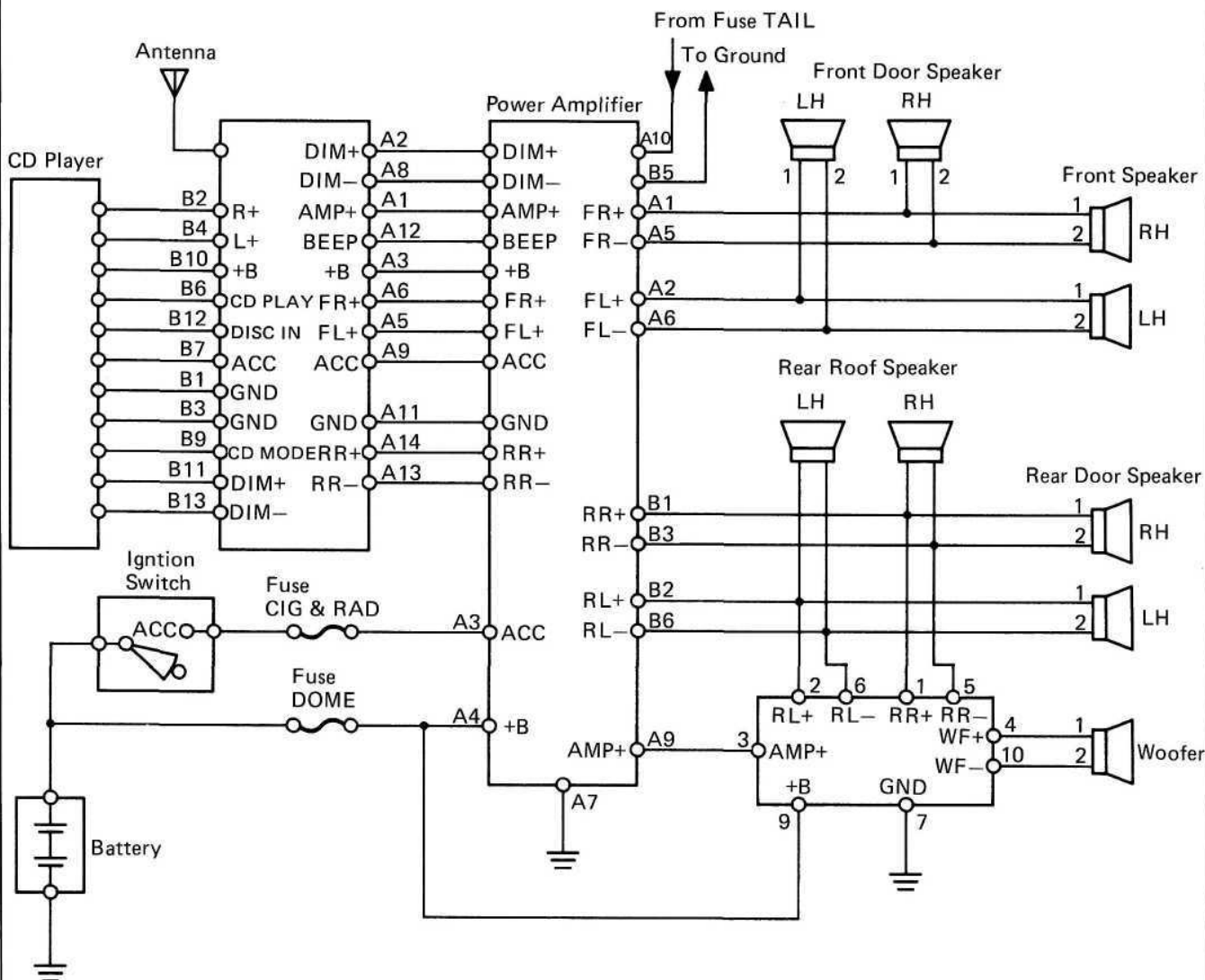

Power Amplifier
 Connector "A" Connector "B"

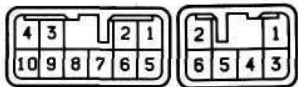

Radio Assembly
 Connector "A" Connector "B"

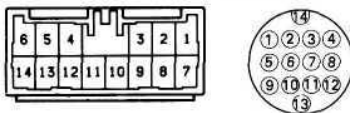

Woofer Amplifier

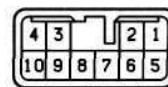

Front Speaker Front Door Speaker Rear Door Speaker Rear Roof Speaker Woofer



Motor Antenna (Except Radio Linked Type)

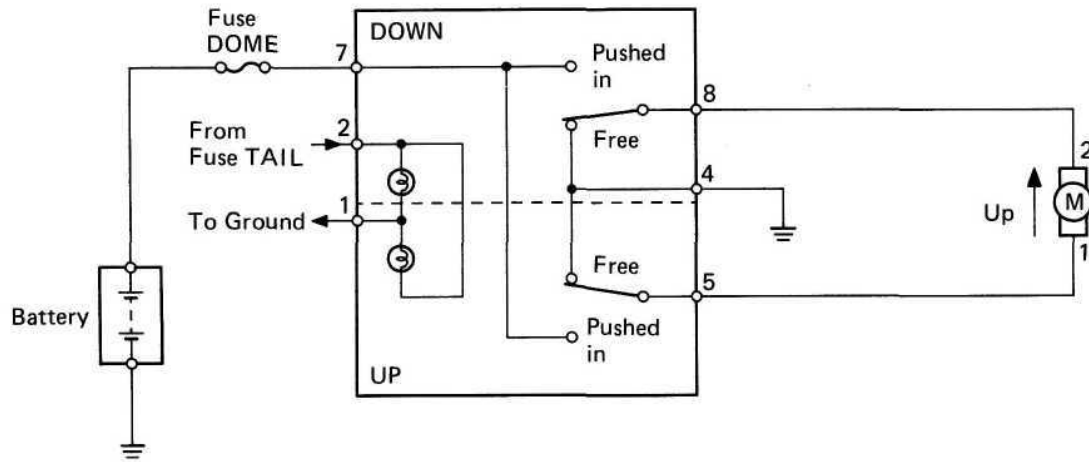

Antenna Switch

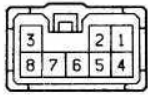

Antenna Motor

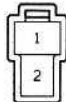

System Description

RADIO WAVE BAND

The radio wave bands used in radio broadcasting are as follows:

Frequency	30 kHz	300 kHz	3 MHz	30 MHz	300 MHz
Designation	LF	MF	HF	VHF	
Radio wave	LW	AM(MW)	SW	FM(UKW)	
Modulation method	Amplitude modulation			Frequency modulation	

LF: Low Frequency MF: Medium Frequency HF: High Frequency VHF: Very High Frequency

HINT: In this section, the term "A M" includes LW, MW and SW, and the term "F M" includes UKW.

SERVICE AREA

There is great difference in the size of the service area for AM, FM monaural, and FM stereo broadcasting. Thus it may happen that FM broadcast cannot be received even though AM comes in very clearly.

Not only does FM stereo have the smallest service area, but it also picks up static and other types of interference ("noise") the most easily.

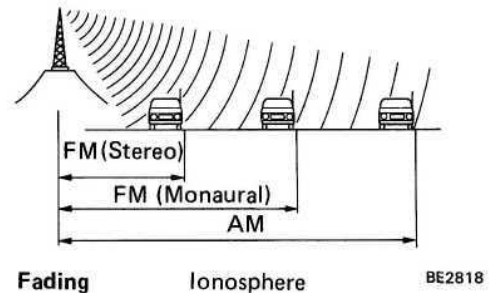

RECEPTION PROBLEMS

Besides the problem of static, there are also the problems called "fading", "multipath", and "fade out". These problems are caused not by electrical noise but by the nature of the radio waves themselves.

Fading

Besides electrical interference, AM broadcasts are also susceptible to other types of interference, especially at night. This is because AM radio waves bounce off the ionosphere at night. These radio waves then interfere with the signals from the same transmitter that reach the vehicle's antenna directly. This type of interference is called "fading".

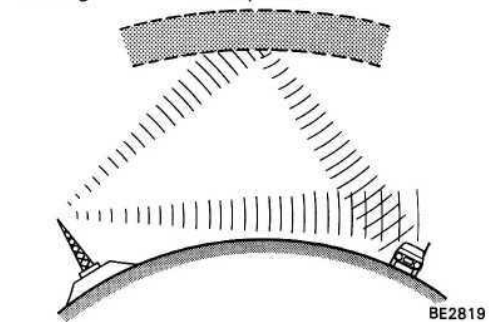

Multipath

One type of interference caused by the bouncing of radio waves off of obstructions is called "multipath". Multipath occurs when a signal from the broadcast transmitter antenna bounces off of buildings and mountains and interferes with the signal that is received directly-

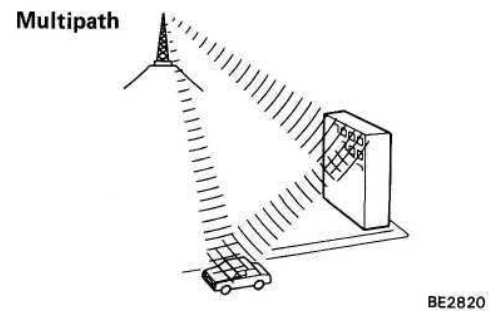

Fade Out

Because FM radio waves are of higher frequencies than AM radio waves, they bounce off of buildings, mountains, and other obstructions. For this reason, FM signals often seem to gradually disappear or fade away as the vehicle goes behind a building or other obstruction. This is called "fade out".

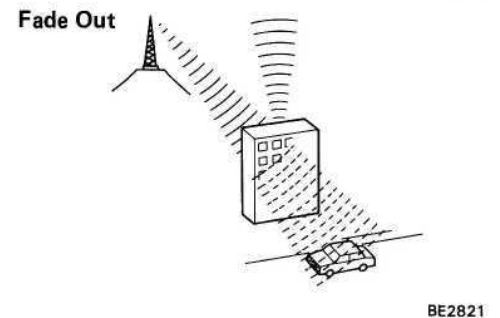

ADJUST ANTENNA TRIMMER

(Ex. Electronic Tuning Radio)

- Fully lengthen antenna.
- With volume and tone at maximum, turn the dial to around 1,400 kHz where there is no reception.
- Adjust the trimmer to where static is loudest.

HINT: The position of the antenna trimmer may vary according to the type of radio, but is always on the front side.

Example:

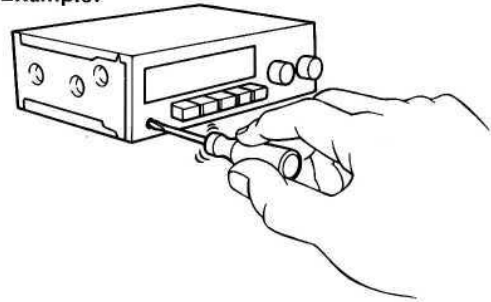

BE0183

COMPACT DISC PLAYER

Compact Disc (hereafter called "CD") players use a laser beam pick-up to read the digital signals recorded on the CD and reproduce analog signals of the music, etc. There are 4.7 in. (12 cm) and 3.2 in. (8 cm) CD available.

HINT: Never attempt to disassemble or oil any part of the player unit. Do not insert any object other than a disc into the slot.

NOTICE: CD players use invisible laser beam which could cause hazardous radiation exposure if directed. Be sure to operate the player correctly as instructed.

MAINTENANCE

(Tape Player)

Head Cleaning

- Raise the cassette door with your finger. Next using a pencil or like object, push in the guide.
- Using a cleaning pen or cotton applicator soaked in cleaner, clean the head surface, pinch rollers and capstans.

Example:

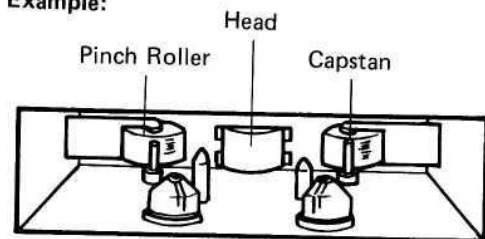

C0192

(CD Player)

Disc Cleaning

If the Disc gets dirty, clean the Disc by wiping the surfaces from the center to outside in the radial directions with a soft cloth.

NOTICE: Do not use a conventional record cleaner or anti-static record preservative.

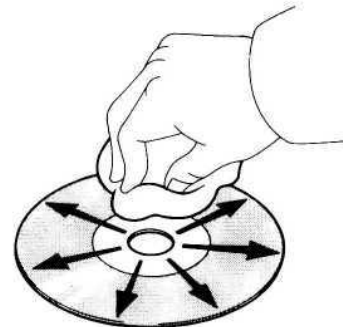

BE4331

HOW TO USE DIAGNOSTIC CHART

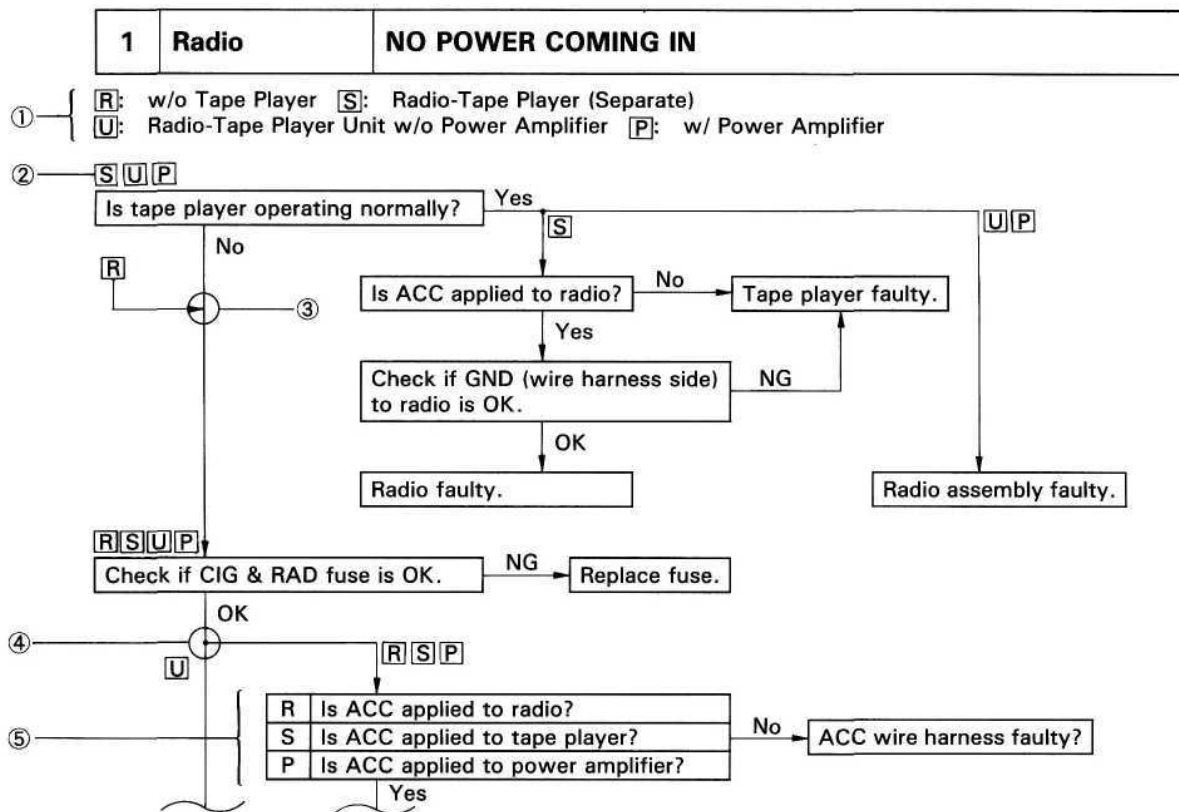

- ① Audio system type and symbol used.
HINT: Confirm the applicable type of audio system.
- ② Symbol for type of audio system the question applies to.
HINT: If the audio system type is not applicable, proceed to next question below.
- ③ Junction without black circle.
HINT: Proceed to next question below.
- ④ Junction with black circle.
HINT: Proceed to question for applicable audio system type.
- ⑤ HINT: Select question for applicable audio system type.

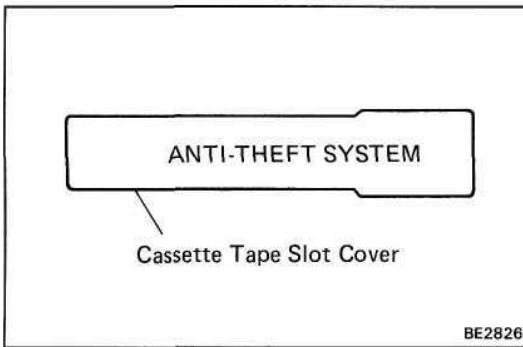

Anti-Theft System

The anti-theft system is only provided for audio systems equipped with an Acoustic Flavor function.

HINT: The words "ANTI-THEFT SYSTEM" are displayed on the cassette tape slot cover.

For operation instructions for the anti-theft system, please consult the audio system section in the Owner's Manual.

1. SETTING SYSTEM

The system is in operation once the customer has pushed the required buttons and entered the customer-selected 3-digit ID number.

(Refer to the Owner's Manual "SETTING THE ANTI-THEFT SYSTEM").

HINT:

- When the audio system is shipped the ID number has not been input, so the anti-theft system is not in operation.
- If the ID number has not been input, the audio system remains the same as a normal audio system.

2. ANTI-THEFT SYSTEM OPERATION

If the normal electrical power source (connector or battery terminal) is cut off, the audio system becomes inoperable, even if the power supply resumes.

3. CANCELLING SYSTEM

The ID number chosen by the customer is input to cancel the anti-theft system.

(Refer to the Owner's Manual, "IF THE SYSTEM IS ACTIVATED")

HINT: To change or cancel the ID number, please refer to the Owner's Manual, "CANCELLING THE SYSTEM".

Troubleshooting

NOTICE: When replacing the internal mechanism (computer part) of the audio system, be careful that no part of your body or clothing comes in contact with the terminals of the leads from the IC, etc. of the replacement part (spare part).

HINT: This inspection procedure is a simple troubleshooting which should be carried out on the vehicle during system operation and was prepared on the assumption of system component troubles (except for the wires and connectors, etc.).

Always inspect the trouble taking the following items into consideration.



- Open or short circuit of the wire harness
- Connector or terminal connection fault
- For audio systems with anti-theft system, troubleshooting items marked (*) indicate that "Troubleshooting for ANTI-THEFT SYSTEM" should be carried out first.

	Problem	No.
Radio	No power coming in.	* 1
	Power coming in, but radio not operating.	* 2
	Noise present, but AM—FM not operating.	3
	Either speaker does not work.	4
	Either AM or FM does not work.	5
	Reception poor (Volume faint).	5
	Few preset tuning bands.	5
	Sound quality poor.	6
	Auto-Radio Information (ARI) not received.	7
	Cannot set station select button.	8
	Preset memory disappears.	8
Tape Player	Cassette tape cannot be inserted.	9
	Cassette tape inserts, but no power.	* 10
	Power coming in, but tape player not operating.	11
	Either speaker does not work.	12
	Sound quality poor (Volume faint).	13
	Tape jammed, malfunction with tape speed or auto-reverse.	14
	APS, SKIP, RPT buttons not operating.	15
	Cassette tape will not eject.	* 16
CD Player	CD cannot be inserted.	17
	CD inserts, but no power.	18
	Power coming in, but CD player not operating.	19
	Sound jumps.	20
	Sound quality poor (Volume faint).	21
	Either speaker does not work.	22
	CD will not eject.	23
Antenna	Antenna—related.	24
Noise	Noise produced by vibration or shock while driving.	25
	Noise produced when engine starts.	26

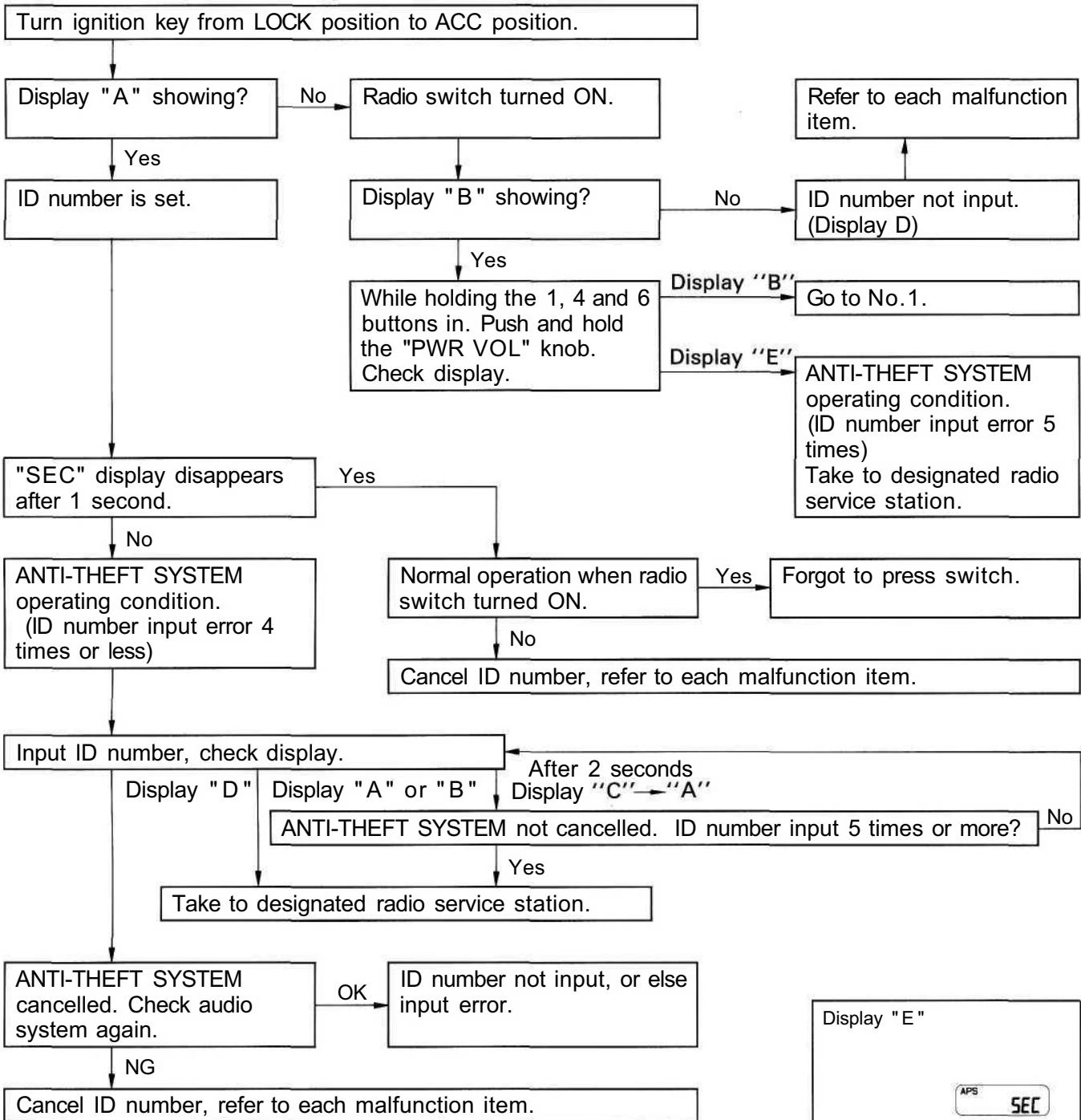
Troubleshooting for ANTI-THEFT SYSTEM

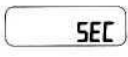
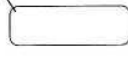
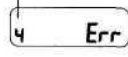
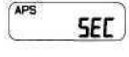

(Liquid Crystal Display (LCD) for Audio System)

<p>Display "A"</p>  <p>BE2814</p>	<p>Display "B"</p> <p>Blank, No Illumination</p>  <p>BE2815</p>	<p>Display "C"</p> <p>Error Times</p>  <p>BE2816</p>	<p>Display "E"</p>  <p>BE3923</p> <p>Display "D" Example: Radio Display</p>  <p>BE2817</p>
--	--	--	--

HINT:

- Refer to Owner's Manual for operation details of ANTI-THEFT SYSTEM.
- When the ID number has been cancelled, reset the same number after completing the operation, or inform the customer that it has been cancelled.

1	Radio	NO POWER COMING IN
----------	--------------	---------------------------

R : Radio **S** : Radio+Tape Player **U** : Radio-Tape Player (Built-in Power Amplifier)
P : Radio-Tape Player (Separate Power Amplifier)

S U P



R

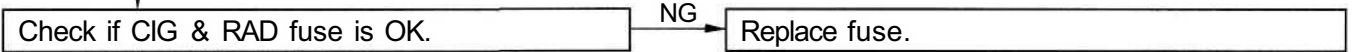

R S U

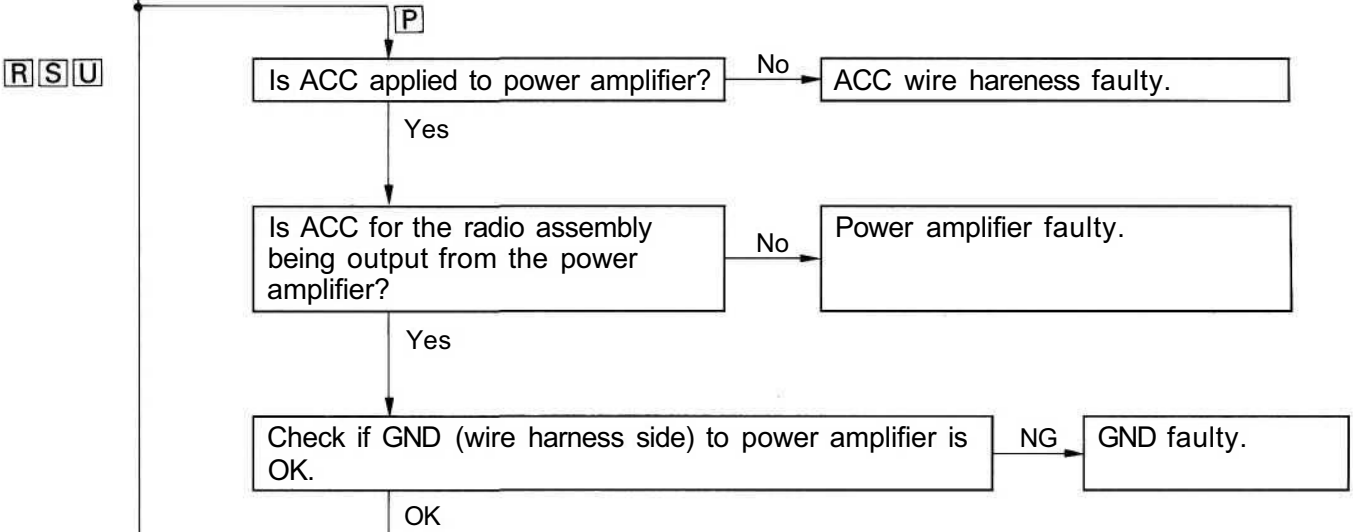

R S U P

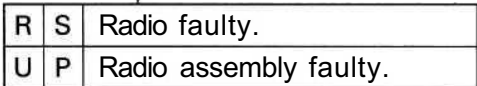
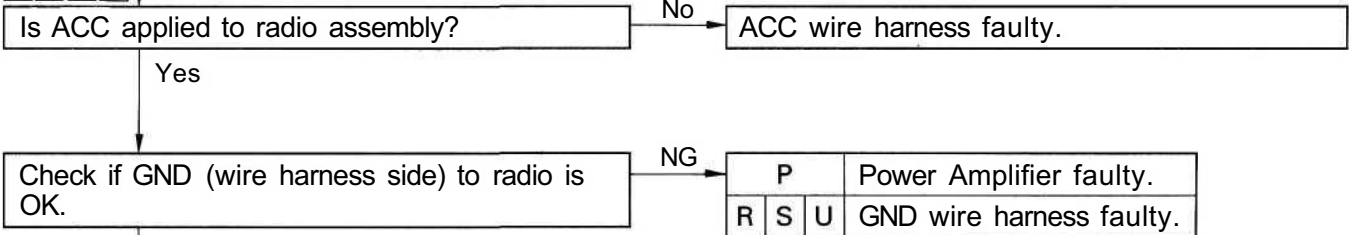

2	Radio	POWER COMING IN, BUT RADIO NOT OPERATING
----------	--------------	---

R : Radio **S** : Radio + Tape Player **U** : Radio—Tape Player (Built-in Power Amplifier)

P : Radio—Tape Player (Separate Power Amplifier)

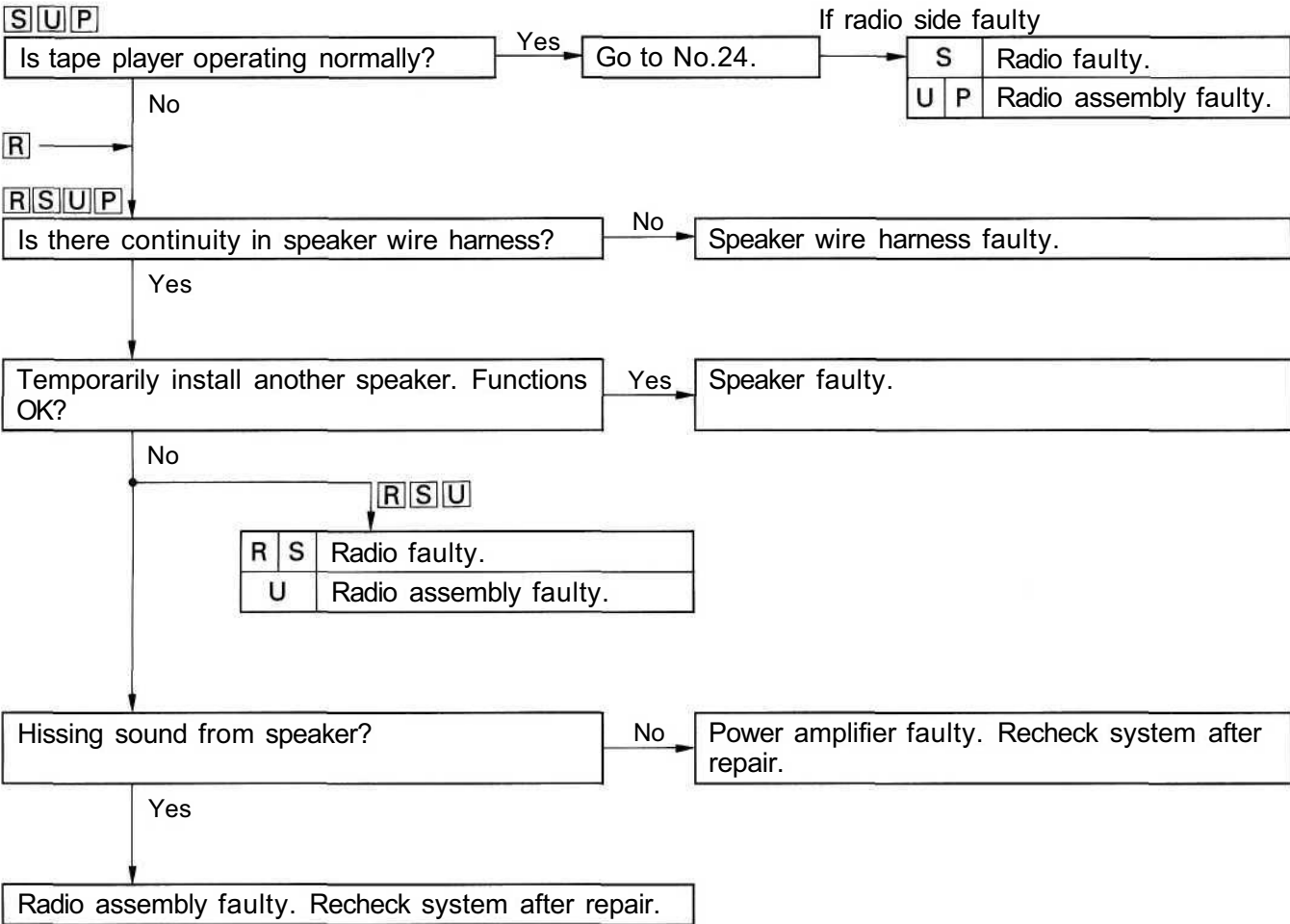

3	Radio	NOISE PRESENT, BUT AM-FM NOT OPERATING
----------	--------------	---

R : Radio **S** : Radio + Tape Player **U** : Radio—Tape Player (Built-in Power Amplifier)

P : Radio—Tape Player (Separate Power Amplifier)

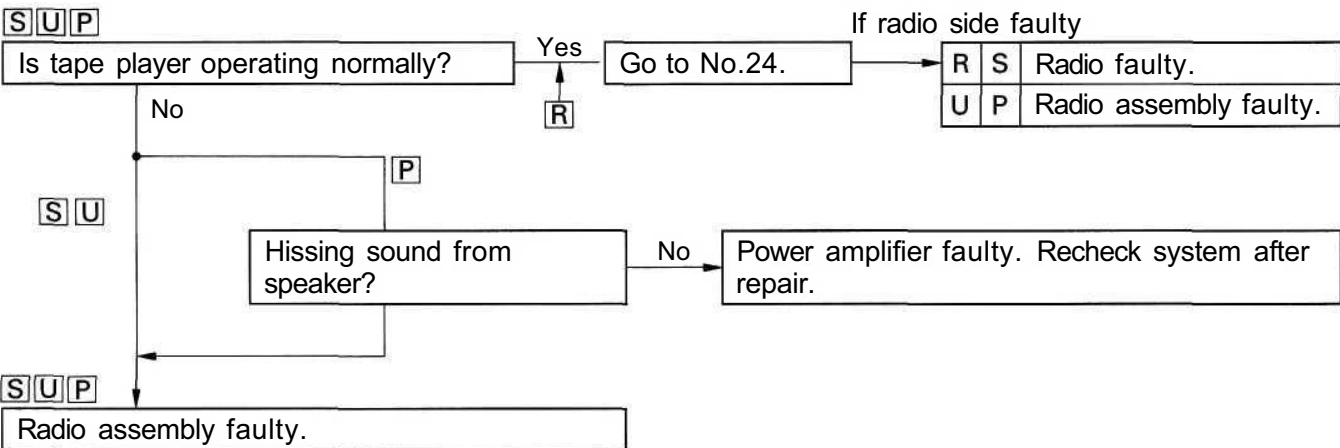

4	Radio	EITHER SPEAKER DOES NOT WORK
----------	--------------	-------------------------------------

R : Radio **S** : Radio + Tape Player **U** : Radio—Tape Player (Built-in Power Amplifier)
P : Radio—Tape Player (Separate Power Amplifier)

S U P

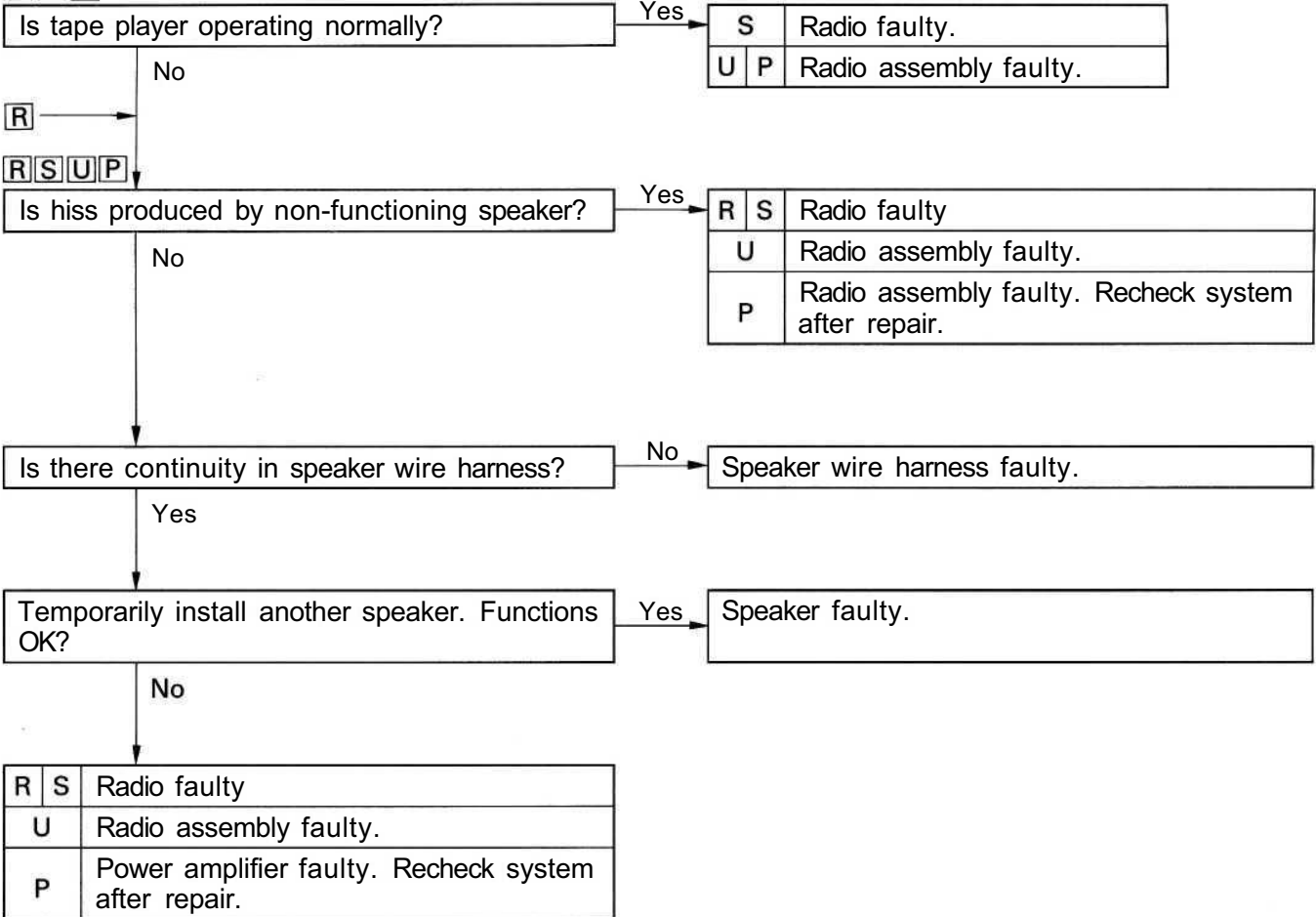

5	Radio	EITHER AM OR FM DOES NOT WORK, RECEPTION POOR (VOLUME FAINT), FEW PRESET TUNING BANDS
----------	--------------	--

R : Radio **S** : Radio+Tape Player **U** : Radio—Tape Player (Built-in Power Amplifier)
P : Radio—Tape Player (Separate Power Amplifier)

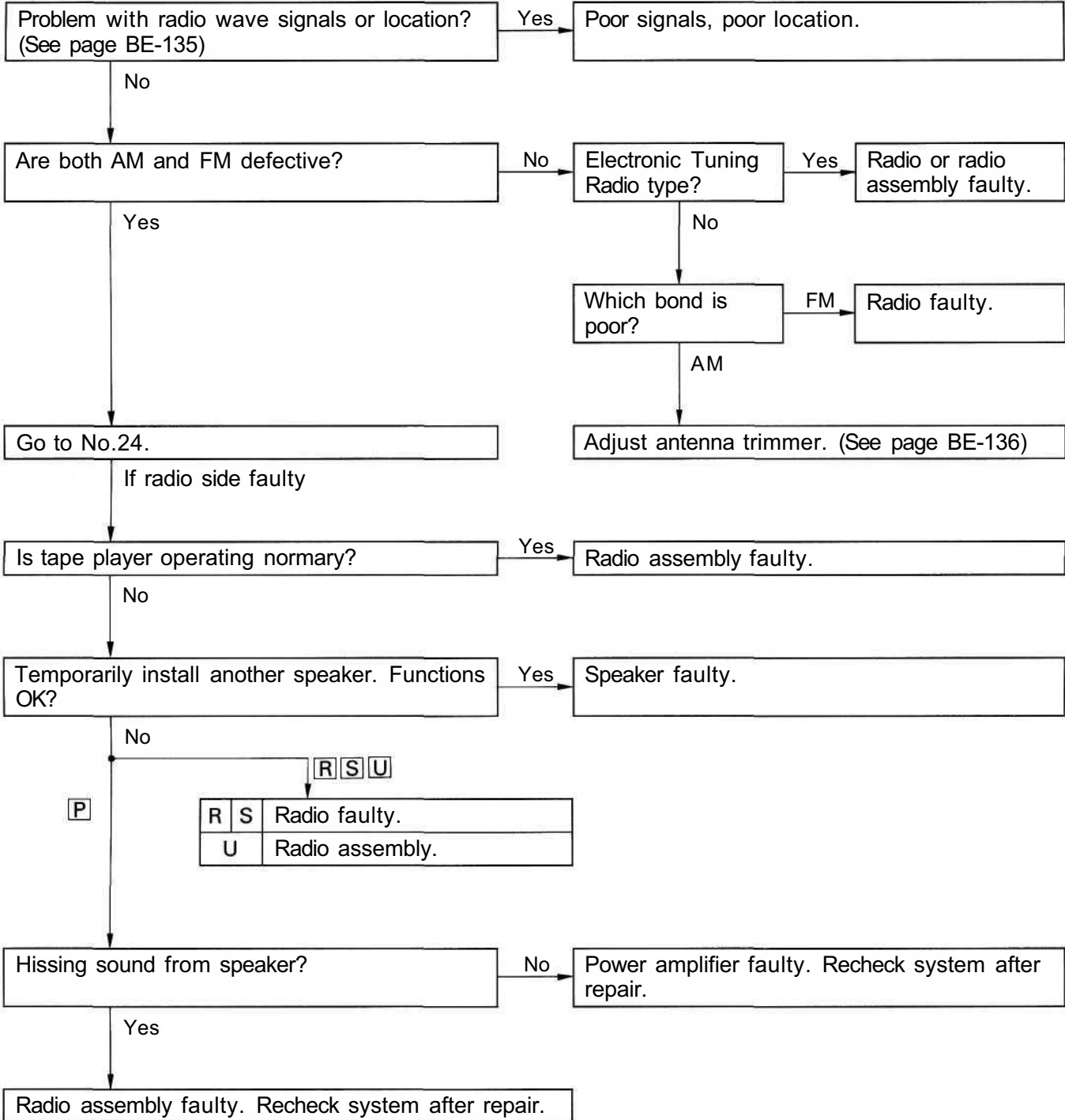

6	Radio	SOUND QUALITY POOR
----------	--------------	---------------------------

R : Radio **S** : Radio+Tape Player **U** : Radio—Tape Player (Built-in Power Amplifier)
P : Radio—Tape Player (Separate Power Amplifier)

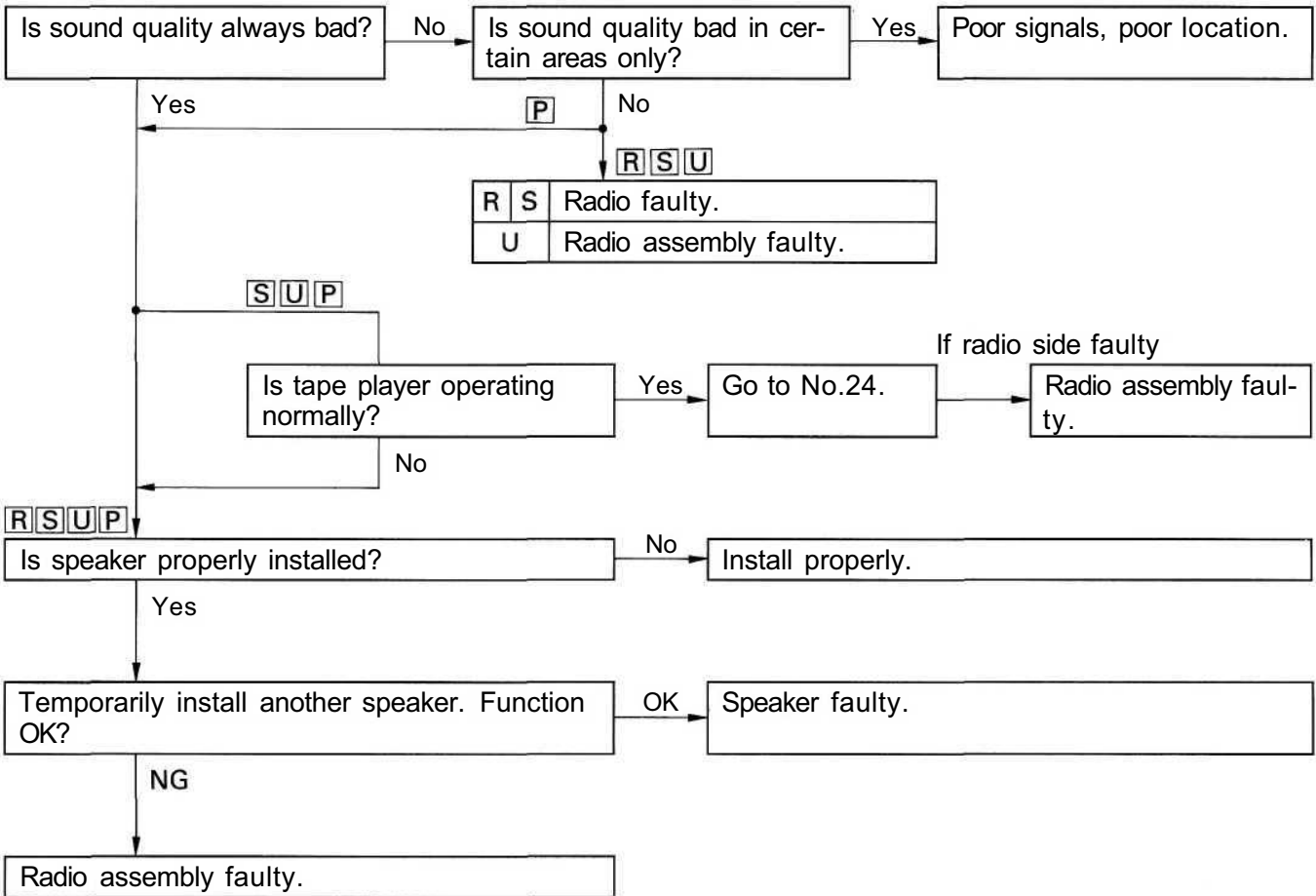

7	Radio	AUTO-RADIO INFORMATION (ARI) NOT RECEIVED
----------	--------------	--

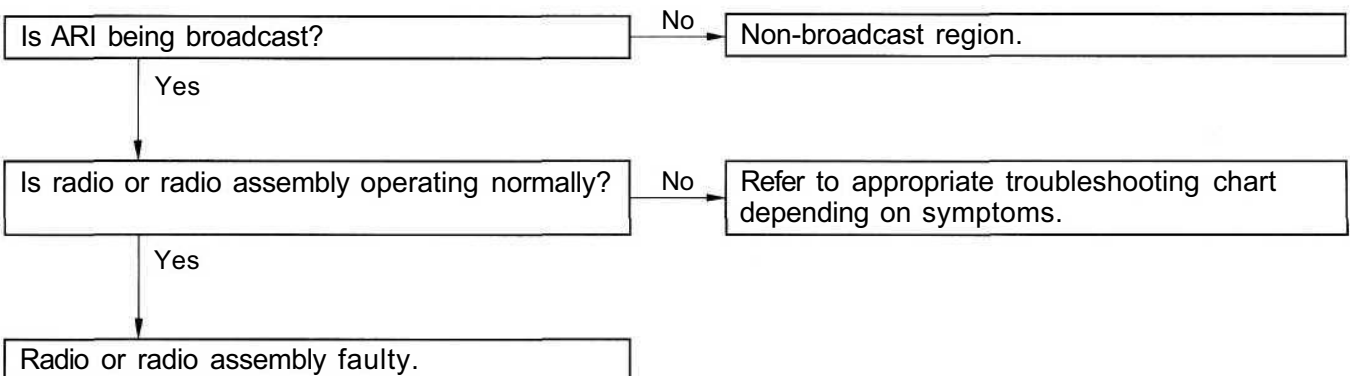

8	Radio	CANNOT SET STATION SELECT BUTTON, PRESET MEMORY DISAPPEARS
----------	--------------	---

R : Radio **S** : Radio+Tape Player **U** : Radio—Tape Player (Built-in Power Amplifier)
P : Radio—Tape Player (Separate Power Amplifier)

S U P

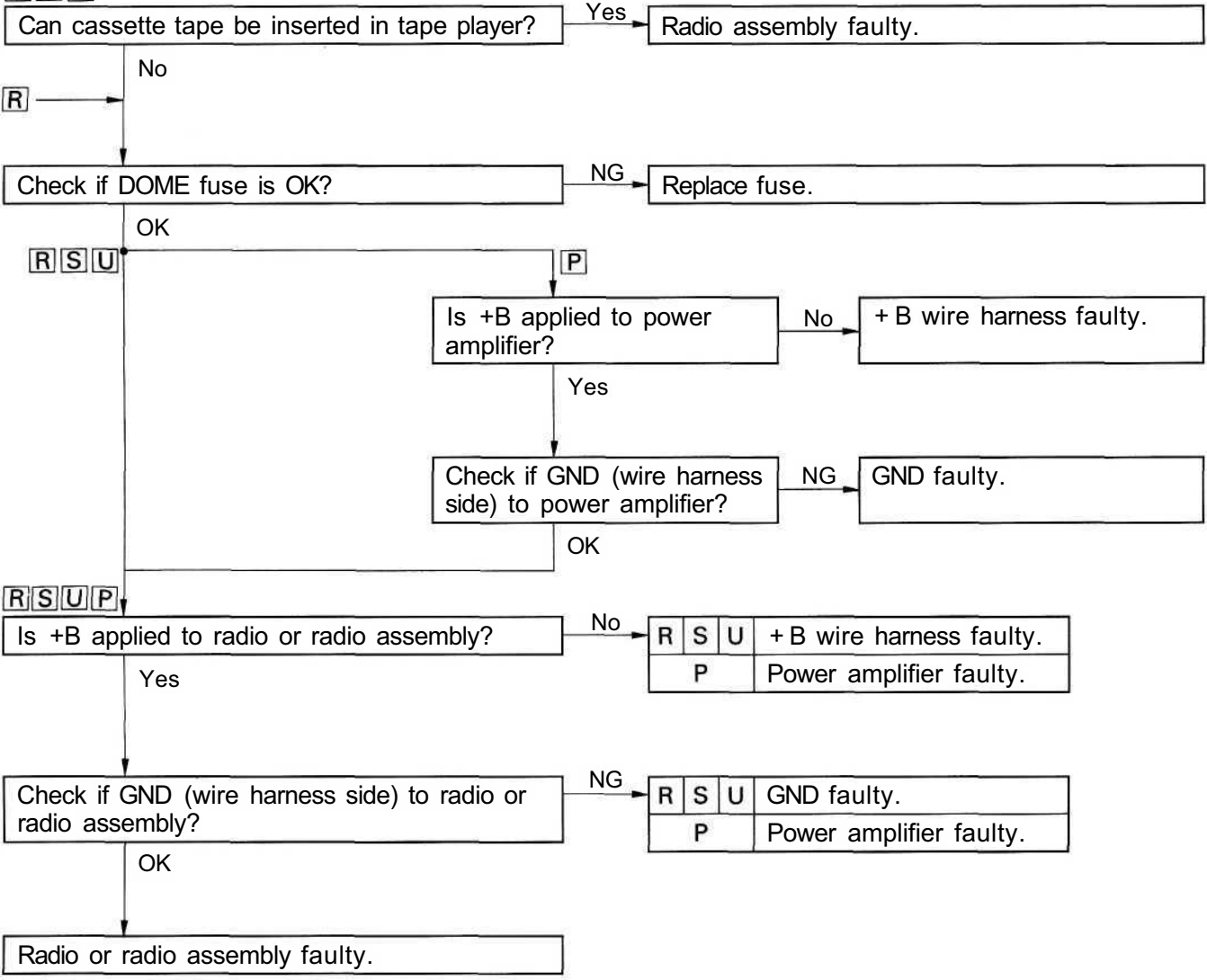

9	Tape Player	CASSETTE TAPE CANNOT BE INSERTED
----------	--------------------	---

S : Radio +Tape Player **U** : Radio —Tape Player (Built-in Power Amplifier)
P : Radio —Tape Player (Separate Power Amplifier)

S U P

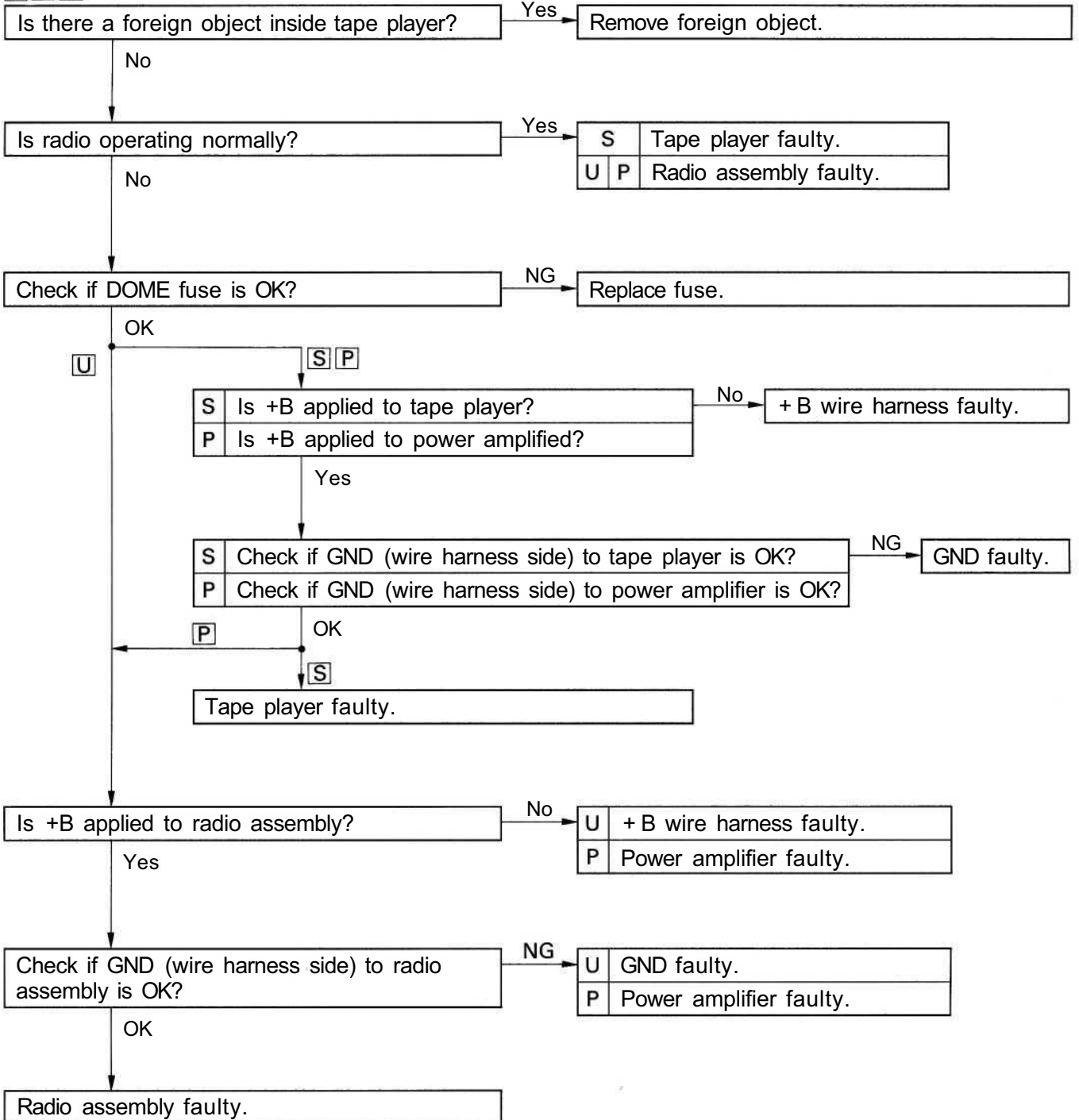

10	Tape Player	CASSETTE TAPE INSERTS, BUT NO POWER
-----------	--------------------	--

S : Radio+Tape Player **U** : Radio—Tape Player (Built-in Power Amplifier)
P : Radio—Tape Player (Separate Power Amplifier)

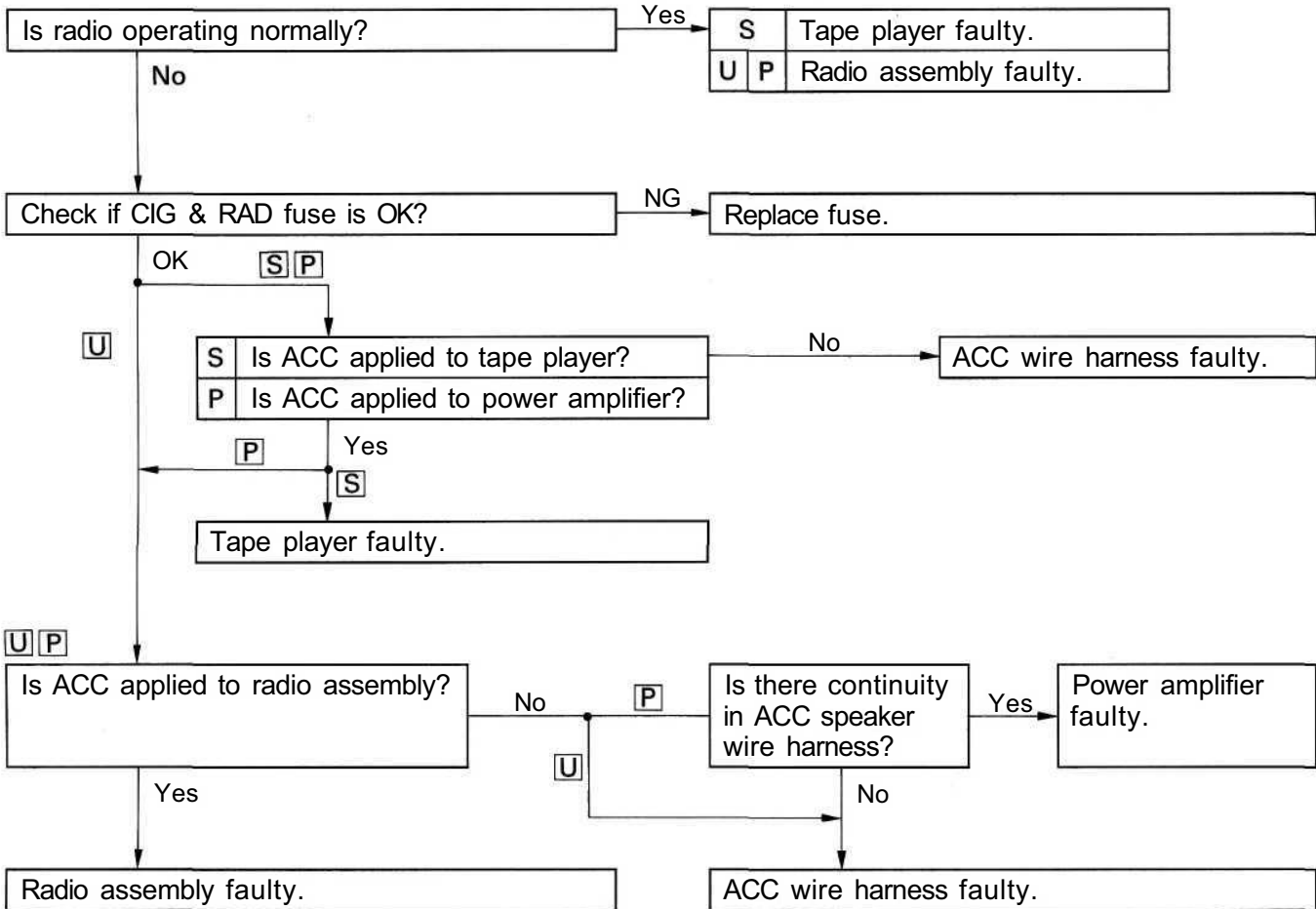

11	Tape Player	POWER COMING IN, BUT TAPE PLAYER NOT OPERATING
-----------	--------------------	---

S : Radio+Tape Player **U** : Radio—Tape Player (Built-in Power Amplifier)
P : Radio—Tape Player (Separate Power Amplifier)

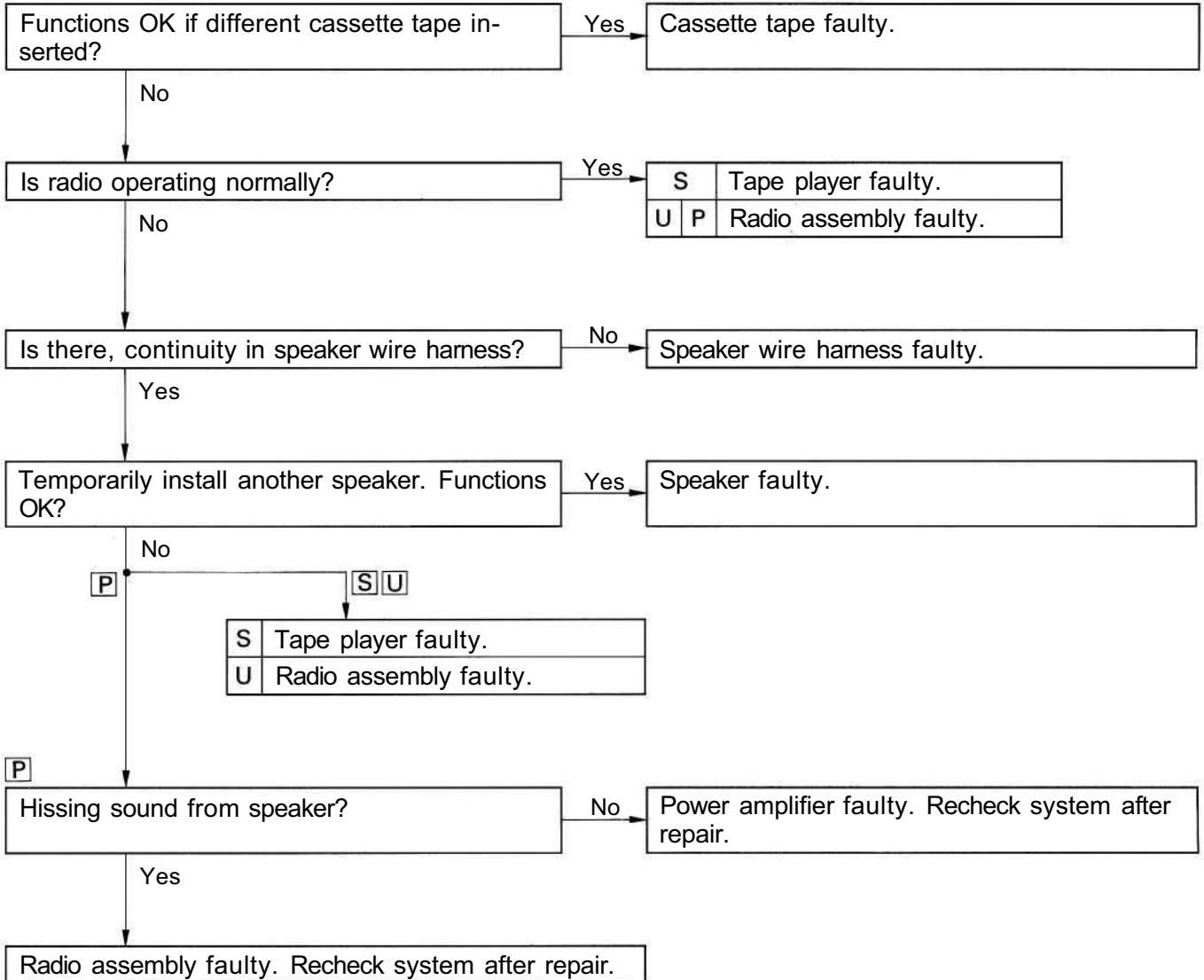

12	Tape Player	EITHER SPEAKER DOES NOT WORK
-----------	--------------------	-------------------------------------

S : Radio + Tape Player **U** : Radio—Tape Player (Built-in Power Amplifier)
P : Radio—Tape Player (Separate Power Amplifier)

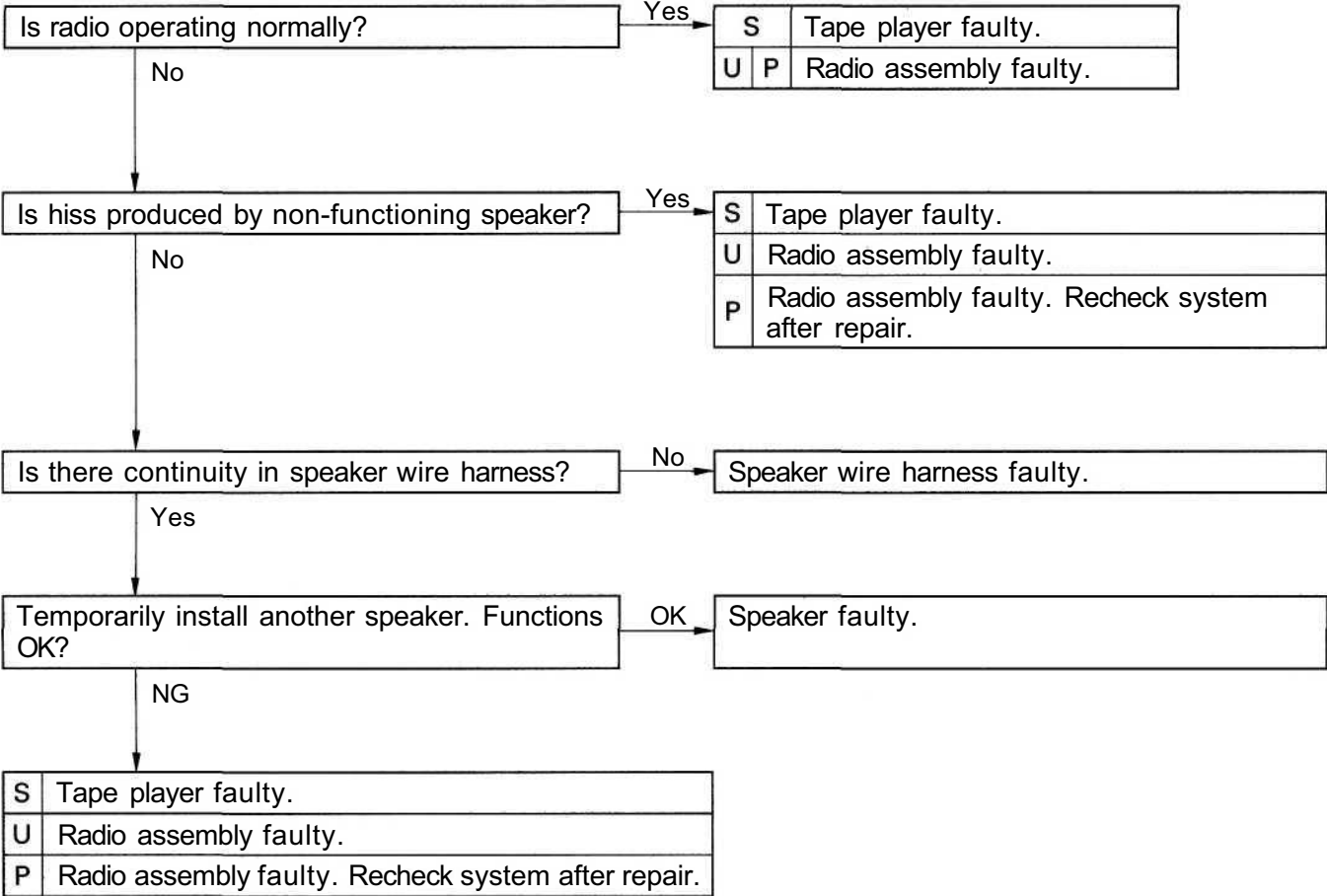

13	Tape Player	SOUND QUALITY POOR (VOLUME FAINT)
-----------	--------------------	--

S : Radio + Tape Player **U** : Radio—Tape Player (Built-in Power Amplifier)

P : Radio—Tape Player (Separate Power Amplifier)

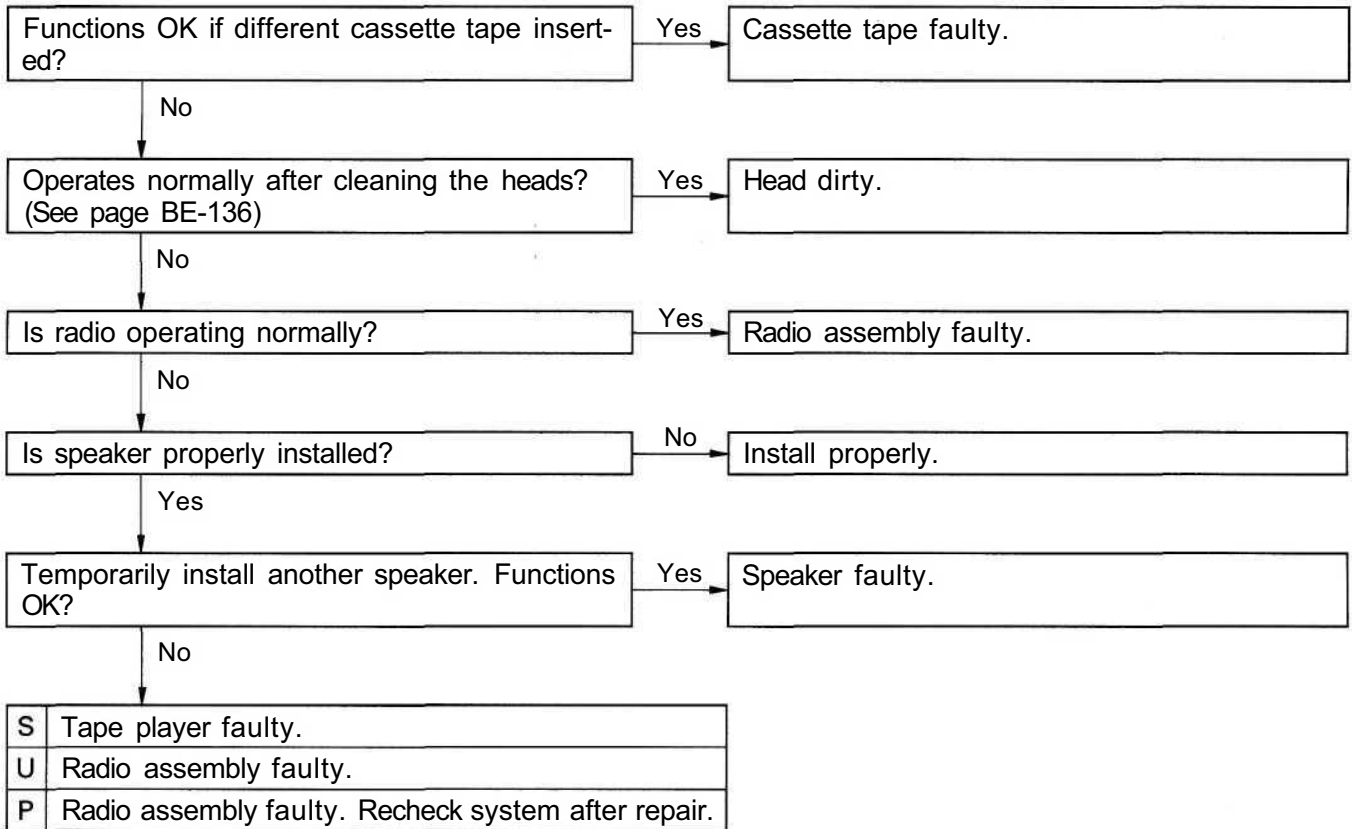

14	Tape Player	TAPE JAMMED, MALFUNCTION WITH TAPE SPEED OR AUTO-REVERSE
-----------	--------------------	---

S : Radio + Tape Player **U** : Radio—Tape Player (Built-in Power Amplifier)

P : Radio—Tape Player (Separate Power Amplifier)

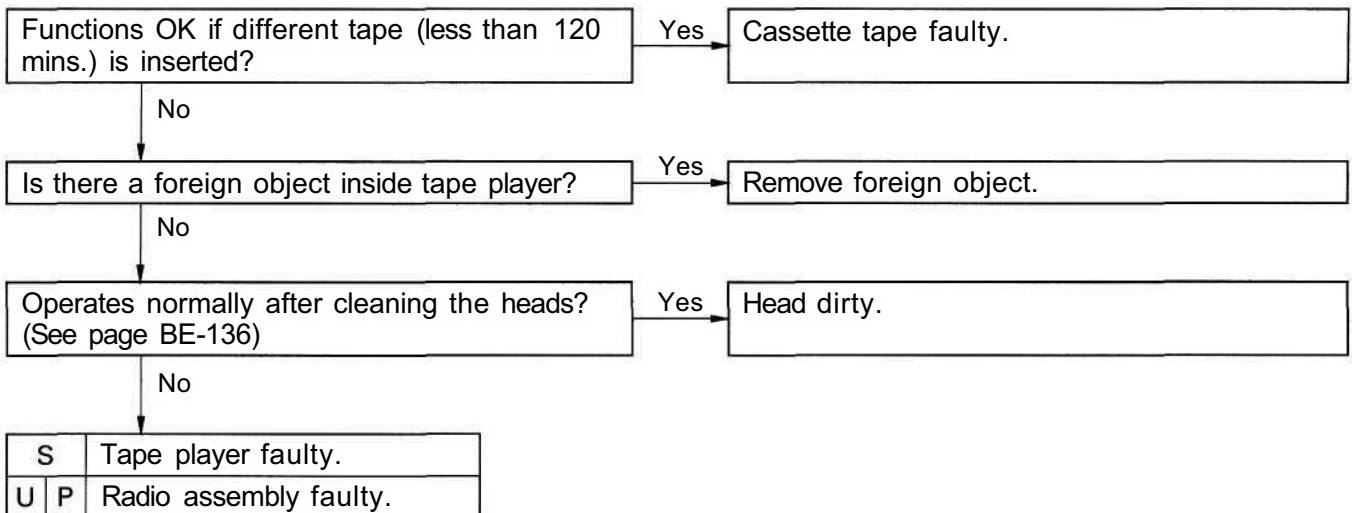

15	Tape Player	APS, SKIP, RPT BUTTONS NOT OPERATING
-----------	--------------------	---

S : Radio+Tape Player **U** : Radio—Tape Player (Built-in Power Amplifier)

P : Radio—Tape Player (Separate Power Amplifier)

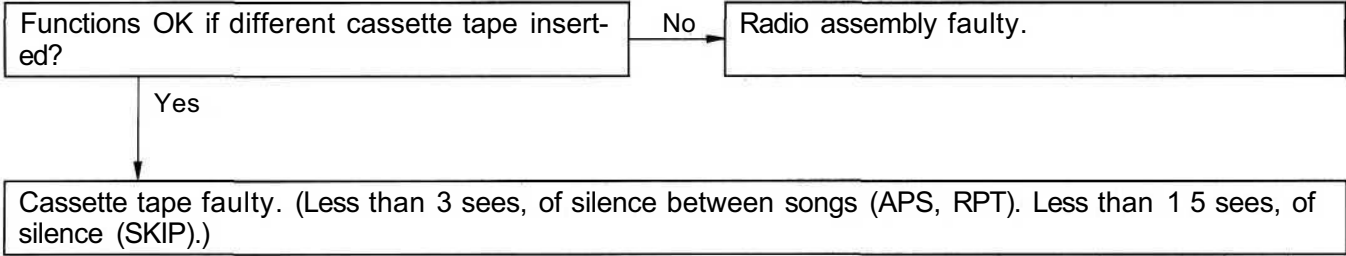

16	Tape Player	CASSETTE TAPE WILL NOT EJECT
-----------	--------------------	-------------------------------------

S : Radio-I-Tape Player **U** : Radio—Tape Player (Built-in Power Amplifier)

P : Radio—Tape Player (Separate Power Amplifier)

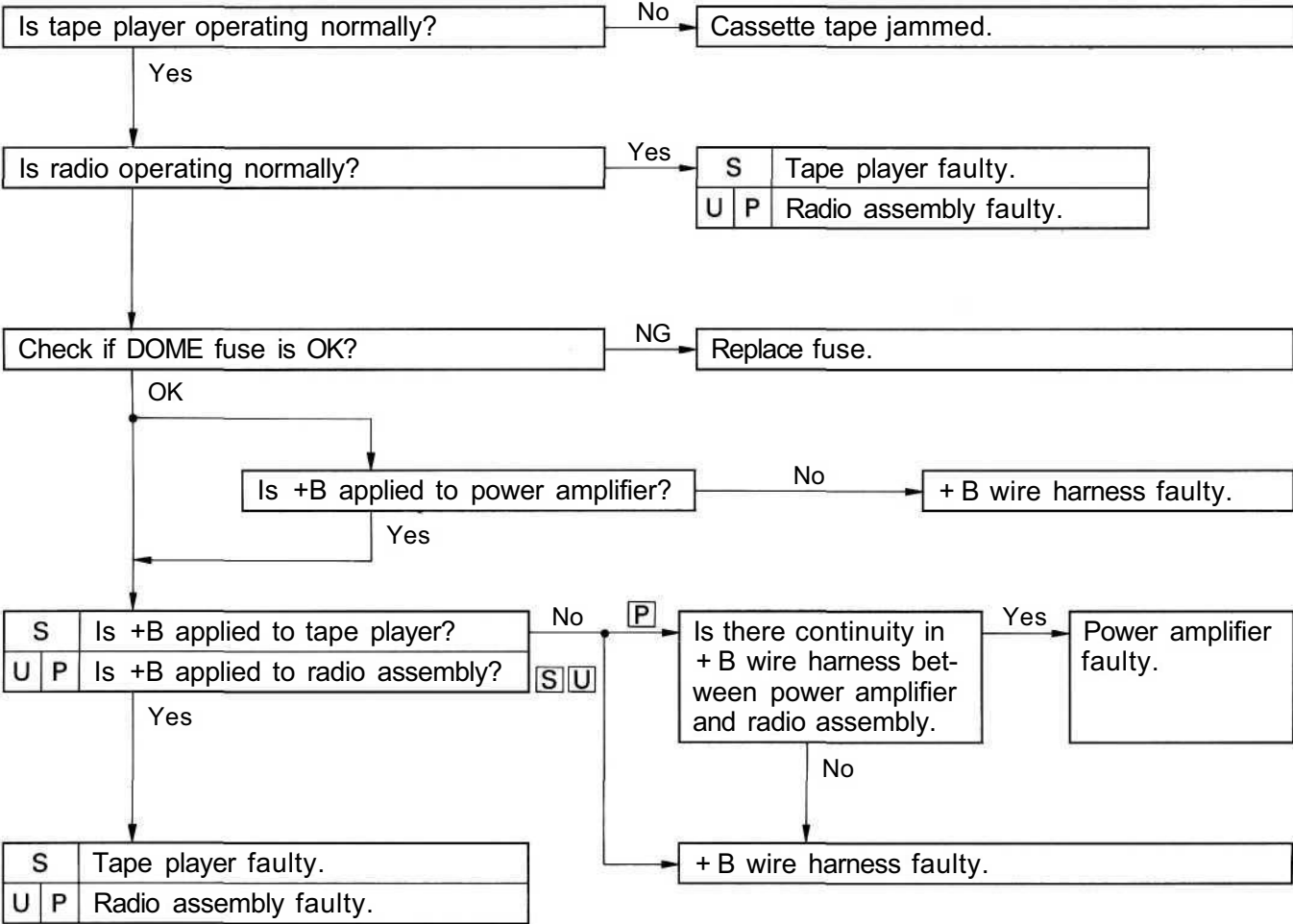

17	CD Player	CD CANNOT BE INSERTED
-----------	------------------	------------------------------

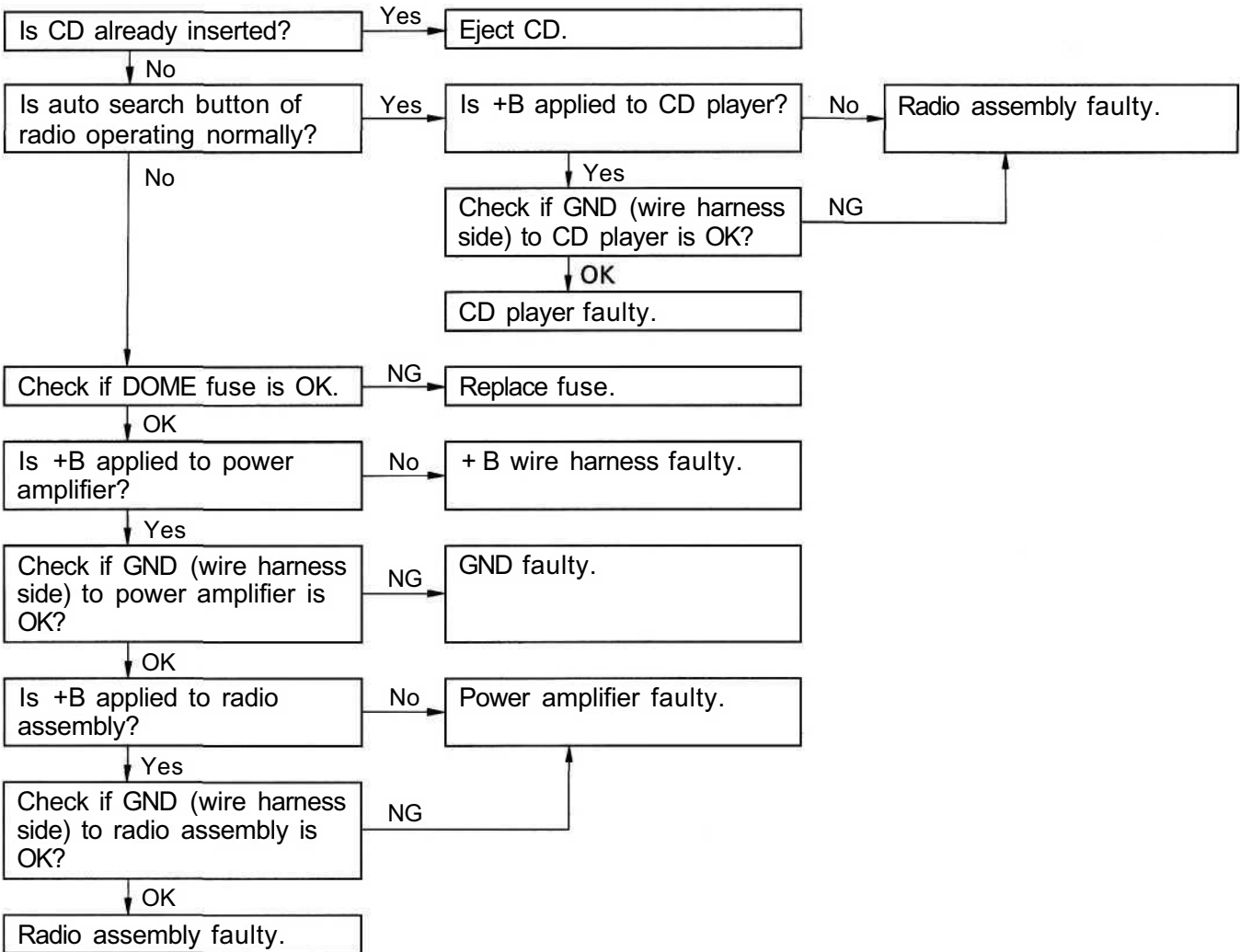

18	CD Player	CD INSERTS, BUT NO POWER
-----------	------------------	---------------------------------

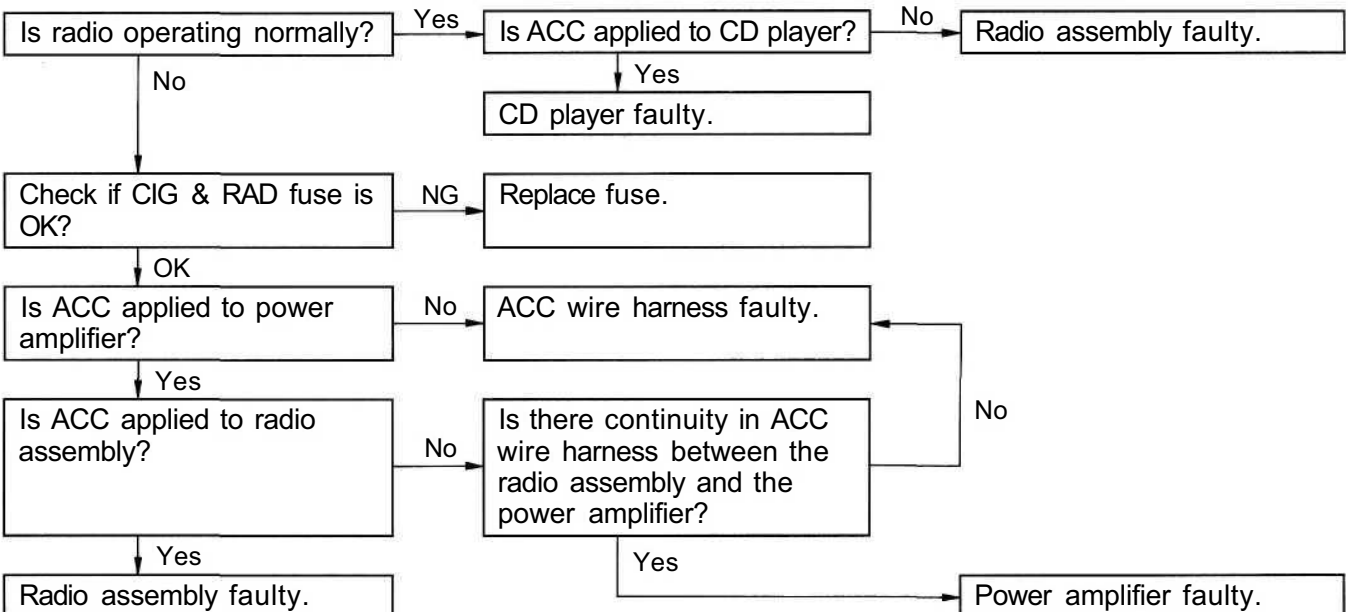

19	CD Player	POWER COMING IN, BUT CD PLAYER NOT OPERATING
-----------	------------------	---

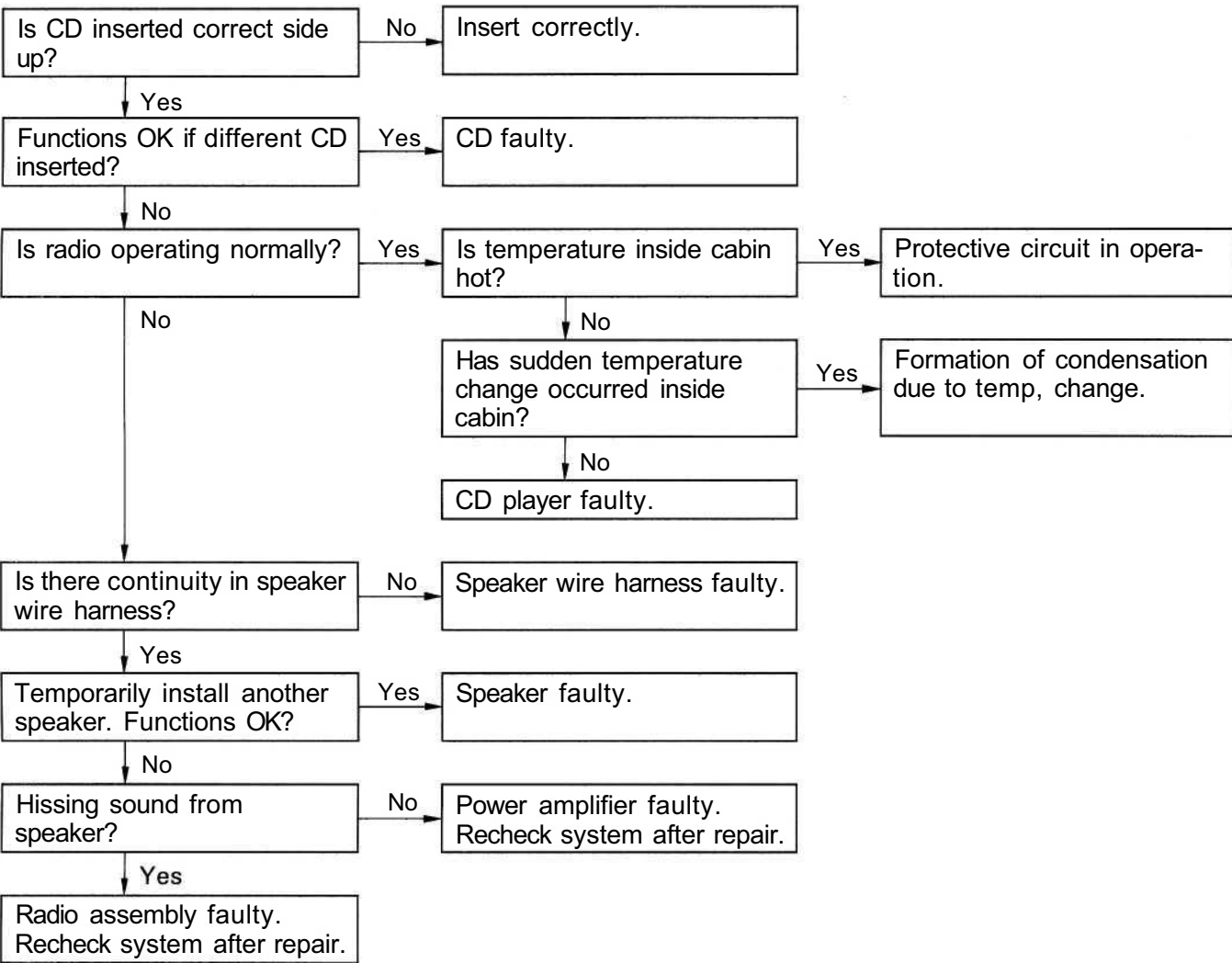

20	CD Player	SOUND JUMPS
-----------	------------------	--------------------

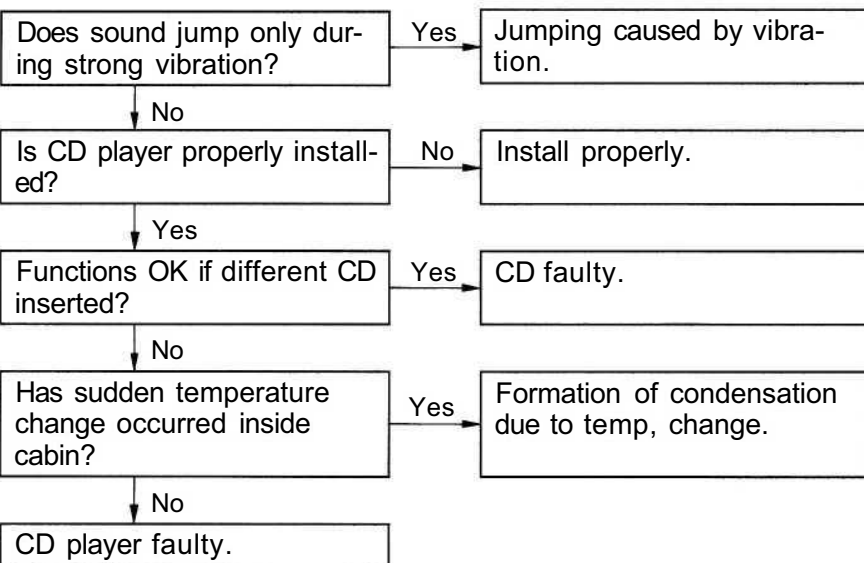

21	CD Player	SOUND QUALITY POOR (VOLUME FAINT)
-----------	------------------	--

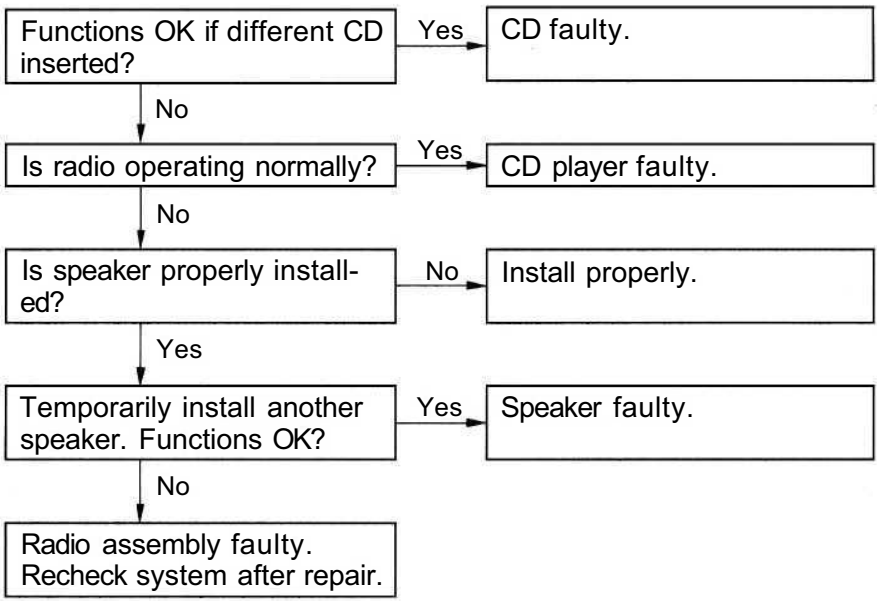

22	CD Player	EITHER SPEAKER DOES NOT WORK
-----------	------------------	-------------------------------------

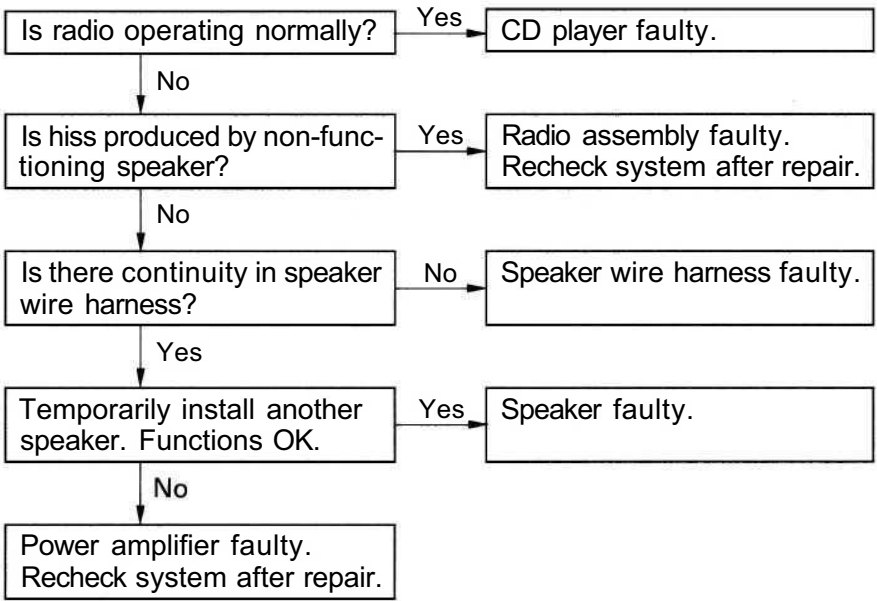

23	CD Player	CD WILL NOT EJECT
-----------	------------------	--------------------------

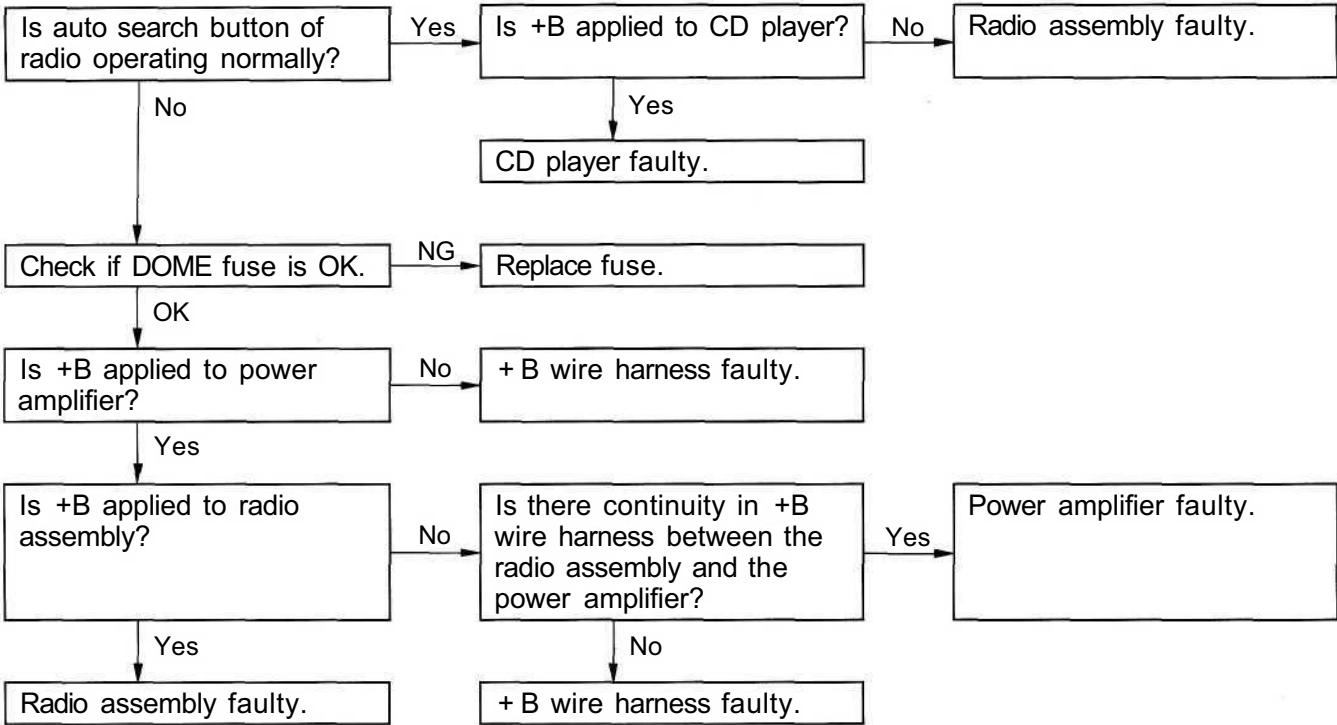

24	Antenna	ANTENNA-RELATED
-----------	----------------	------------------------

24—a: Pole Antenna

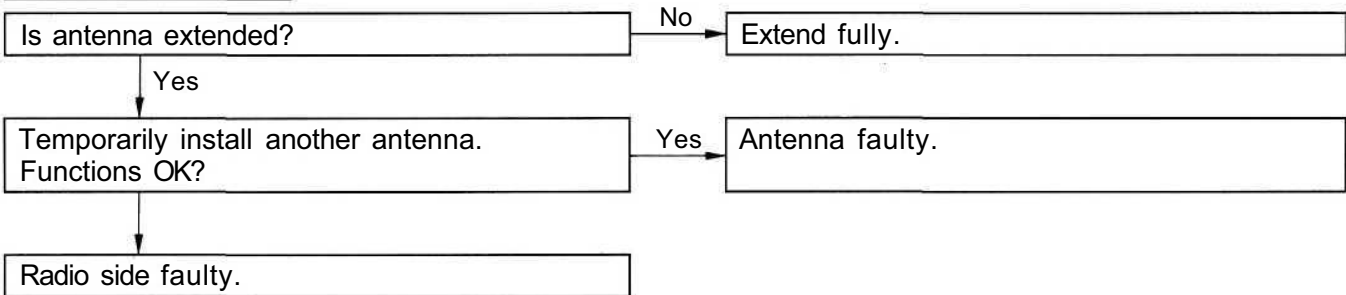

24—b: Motor Antenna

M : Motor Antenna (Radio Linked Type) **N** : Motor Antenna (Except Radio-Linked Type)

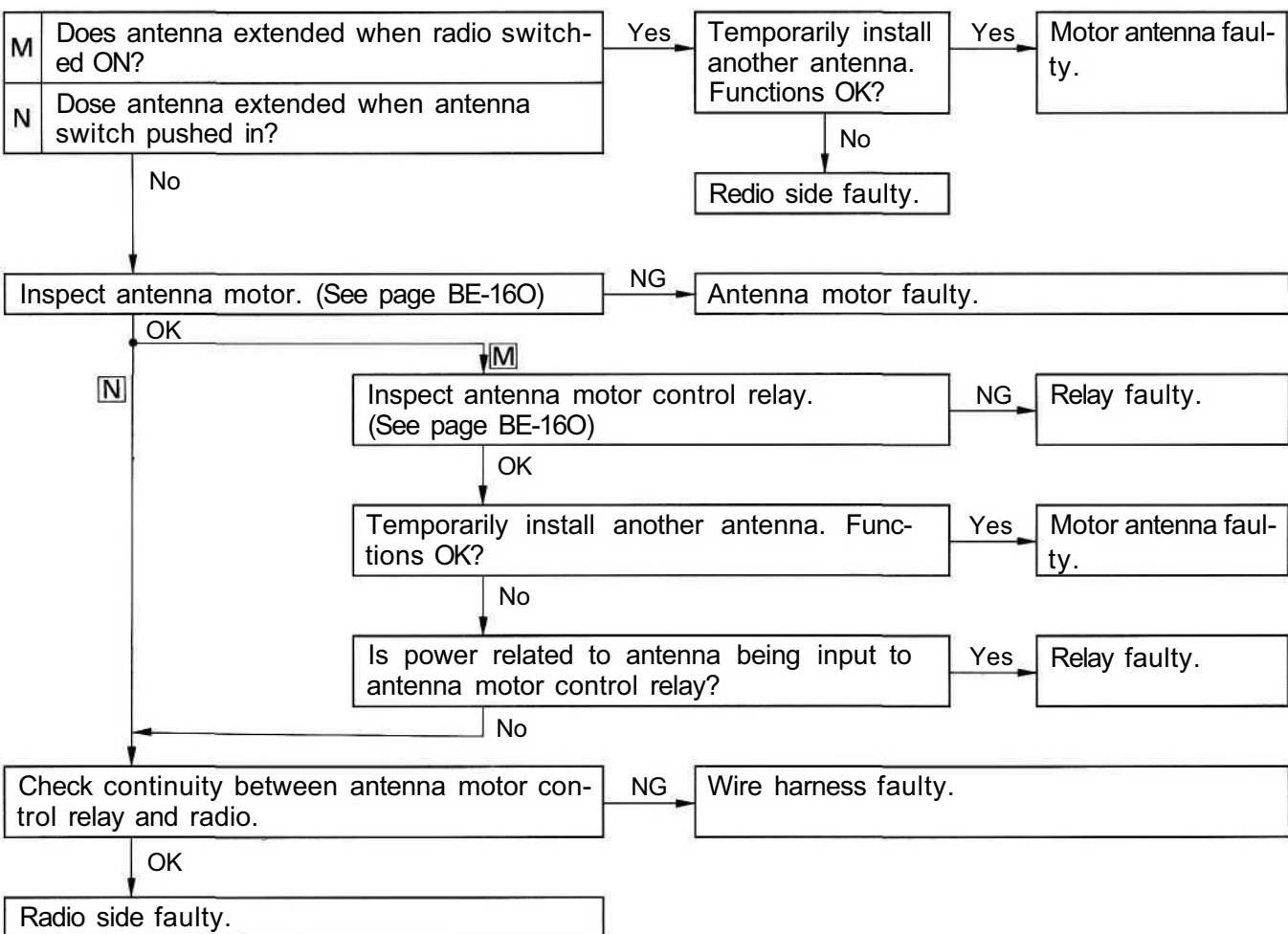

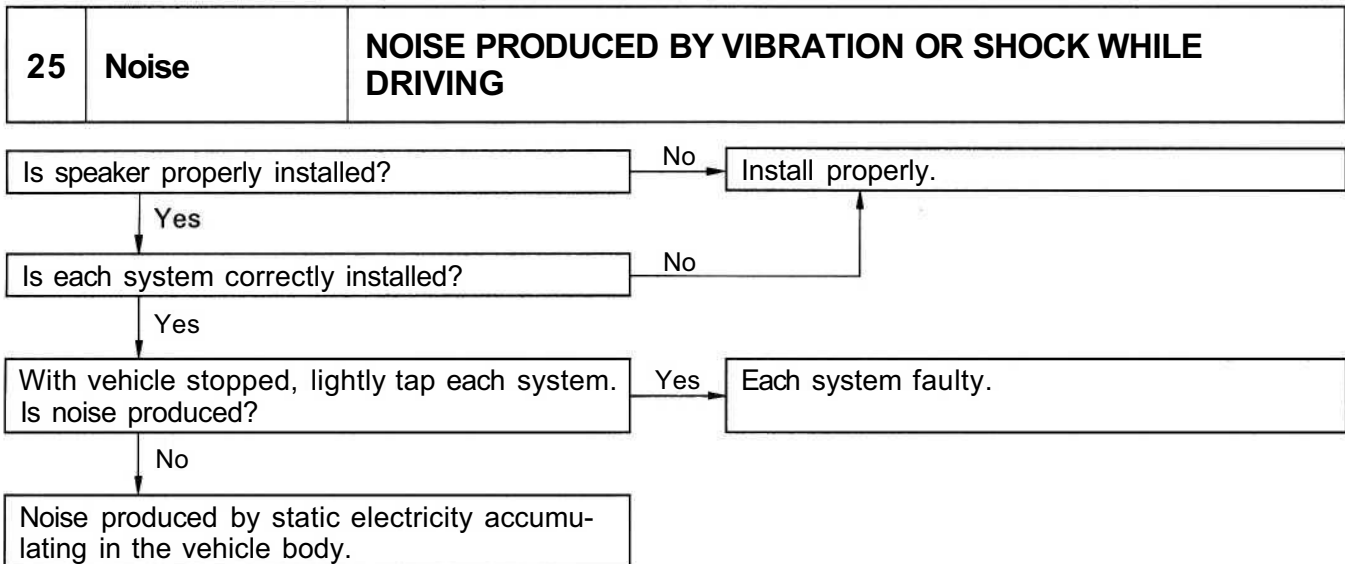

26	Noise	NOISE PRODUCED WHEN ENGINE STARTS
-----------	--------------	--

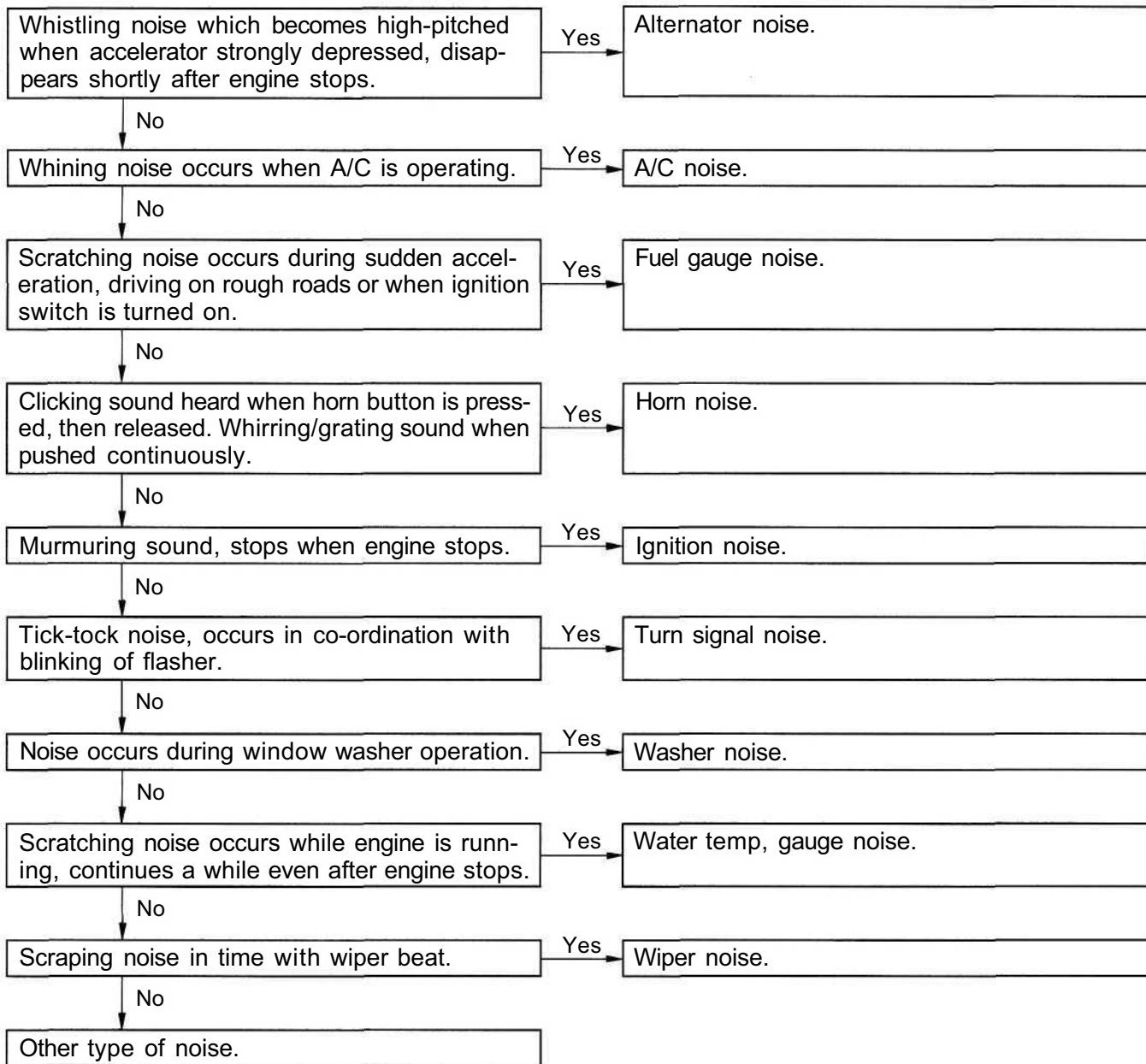

Parts Inspection (with Motor Antenna)

1. INSPECT ANTENNA SWITCH (Except Radio-Linked Type/Continuity)

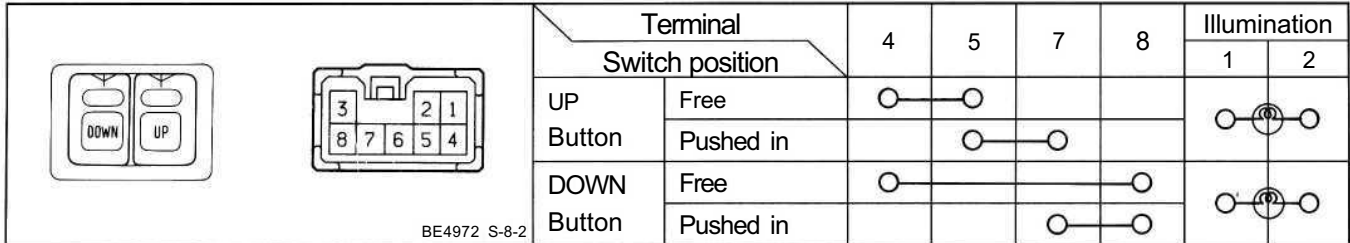

If continuity is not as specified, replace the switch.

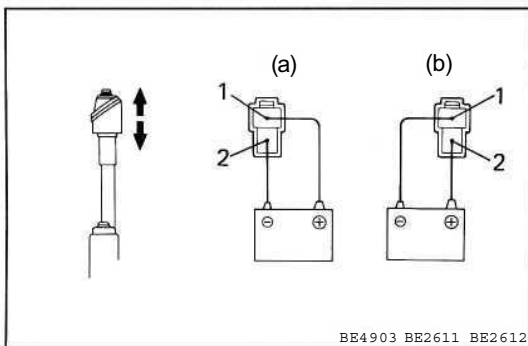

2. INSPECT ANTENNA MOTOR

- (a) Connect the positive (+) lead from the battery to terminal 1 and the negative (—) lead to terminal 2, check that the motor turns (moves upward.)
 - (b) Then, reverse the polarity, check that the motor turns the opposite way (moves downward.)
- If operation is not as specified, replace the motor.

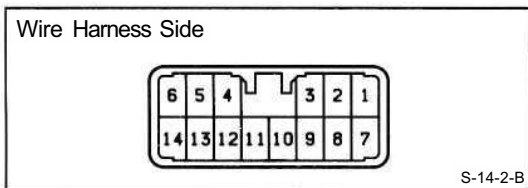

3. INSPECT ANTENNA MOTOR CONTROL RELAY (Radio—Linked Type / Relay circuit)

Disconnect the connector from the relay and inspect the connector on wire harness side as shown in the chart.

Check for	Tester connection	Condition		Specified value
Continuity	2 - 5	Constant		Continuity
	4 — Ground	Constant		Continuity
Voltage	3 — Ground	Constant		Battery voltage
	6 — Ground	Ignition switch position	LOCK or ACC	No voltage
			ON	Battery voltage
	14 — Ground	Ignition switch position	LOCK	No voltage
ACC or ON			Battery voltage	

Continued on Next Page.

Continued from Previous Page.

Check for	Taster connection	Condition				Specified value
		Ignition switch	Radio switch	Radio band	Casette	
Voltage	9 — Ground	LOCK	—	—	—	No voltage
		ACC or ON	OFF	—	OFF	No voltage
		ACC or ON	ON	—	—	Battery voltage
		ACC or ON	—	—	ON	Battery voltage
	11 — Ground	LOCK	—	—	—	No voltage
		ACC or ON	OFF	—	—	No voltage
		ACC or ON	ON	—	OFF	Battery voltage
		ACC or ON	ON	—	ON	No voltage
	12 — Ground	LOCK	—	—	—	No voltage
		ACC or ON	OFF	—	—	No voltage
		ACC or ON	ON	AM	OFF	Battery voltage
		ACC or ON	ON	AM	ON	No voltage
		ACC or ON	ON	FM	OFF	No voltage
	13 — Ground	LOCK	—	—	—	No voltage
		ACC or ON	OFF	—	—	No voltage
		ACC or ON	ON	—	OFF	Battery voltage
ACC or ON		ON	—	ON	No voltage	

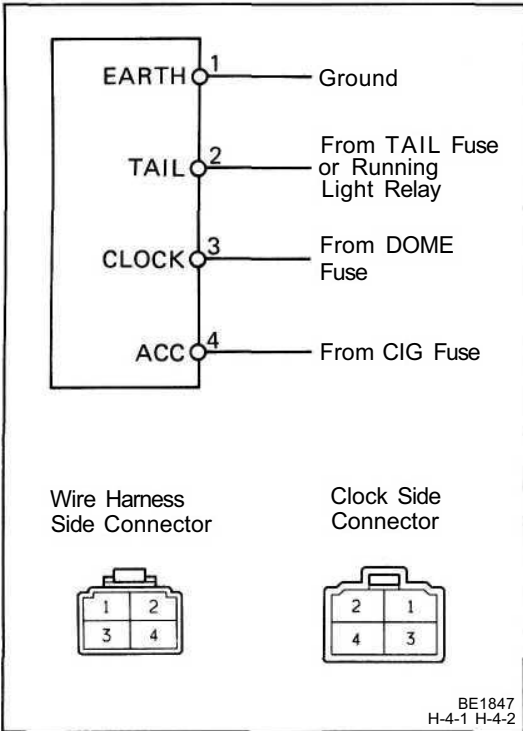

CLOCK

Troubleshooting

As shown in the illustration, those are clock circuit and connector diagrams. Inspect each terminal for applicable trouble.

Terminal		Condition	Specified value
1	EARTH	Constant	Continuity
3	CLOCK	Constant	Battery Voltage
2	TAIL	Turn light control switch ON	
4	ACC	Turn ignition switch ON or ACC	

Allowable error: ±1.5 seconds/day

BE1847
H-4-1 H-4-2